



WSS6

Water Source Heat Pump

HydroTech[™]
Slim 16

3/4 thru 2.5 Tons

16 EER



R454B

NOMENCLATURE

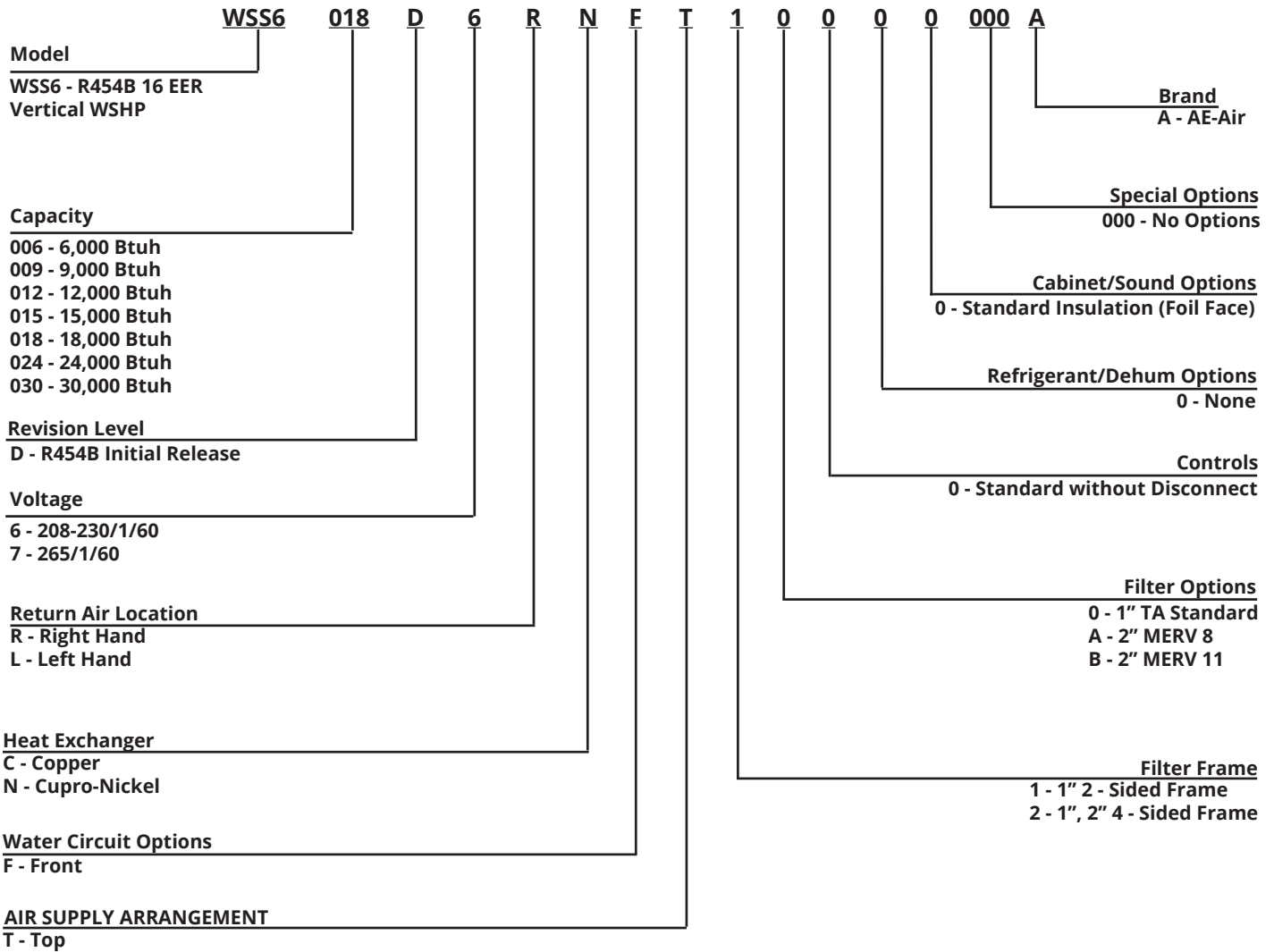

DEFINITIONS

Abbreviations and Definitions

cfm	= airflow, cubic feet per minute	EER	= Energy Efficient Ratio
EWT	= entering water temperature, Fahrenheit	COP	= Coefficient of Performance
gpm	= water flow in gallons per minute	LWT	= leaving water temperature, °F
WPD	= water pressure drop, psi and feet of water	LAT	= leaving air temperature, °F
EAT	= entering air temperature, Fahrenheit (dry bulb/wet bulb)	TH	= total heating capacity, MBtu/h
HC	= air heating capacity, MBtu/h	LC	= latent cooling capacity, MBtu/h
TC	= total cooling capacity, MBtu/h	S/T	= sensible to total cooling ratio
HR	= total heat of rejection, MBtu/h		
HE	= total heat of extraction, MBtu/h		

Introducing

AE-Air is pleased to introduce *the all-new WSSlim16 HydroTech water source heat pump.*

Designed by contractors for contractors, the WSS6 is the most feature-packed product in the HydroTech line.

The WSS6 includes many standard features found only in higher priced products, plus a number of unique features, including:

- **Having the smallest footprint of any product in its class ensures a great fit when replacing older models in tight closets.**
- **Optional Vacated Premises Control (VPC) kit with reset feature:** Ensures that the unit will operate a minimum of one or two hours per day during extended periods of non-occupancy. This option also includes an automatic reset feature. If a fault occurs, the system will shut down, automatically resetting every 24 hours. If the same fault exists each day, the unit will lockout on the fourth day and have to be manually reset.
- **Superior insulation:** Fully insulated with high density close cell foam which offers greater sound absorption and better thermal efficiency.
- **Cabinet design:** Less than 2% leak loss on the cabinet and slide out chassis.
- **Removable discharge flange:** Provides additional installation clearance.
- **Tool-less Filter rack installation:** Can be installed after the unit is in the closet, providing additional installation clearance.
- **State-of-the-Art electronic control module with diagnostic site glass**

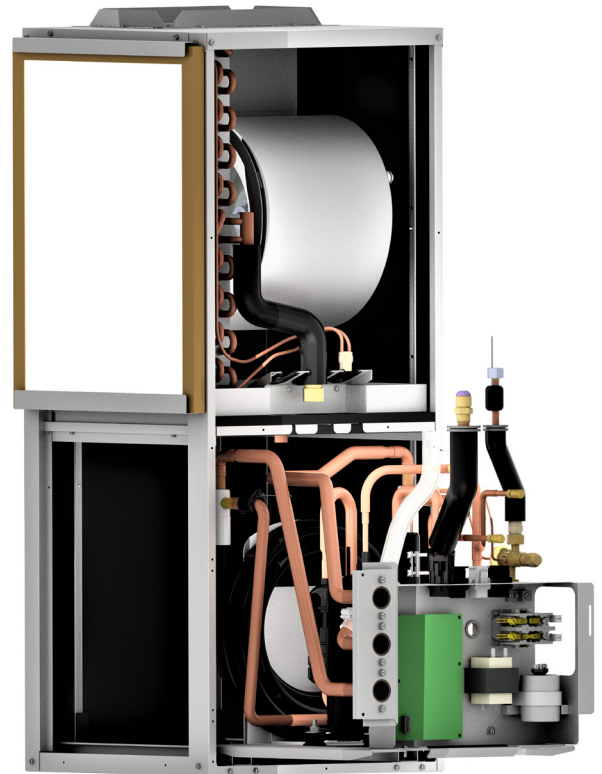

FEATURES AND BENEFITS

Footprint is the smallest in the industry

- A 30% reduction in footprint as compared to other models in the industry.

Serviceability Features:

- Slide out refrigeration section for big service items like compressor, TXV and reversing valve
- Electrical harness with removable moxex plugs for easy removal of the electrical box
- Torch-less removal of refrigeration section in the building
- Minor items like TXV adjustment, refrigerant connections, pressure switches in the front
- All electrical components in the front for easy access
- See through sight glass for troubleshooting without removing panels

Low Water Pressure Drops:

- Reduces pumping demand and lowers building energy consumption

Very Low Sound

- Deep tunnel blower discharge
- Double isolated compressor mount
- Closed cell insulation
- Insulated panels
- Low waterside pressure drop to reduce water flow sounds.

Filter Options:

- 1" filter rack standard.
- 2" filter rack option.

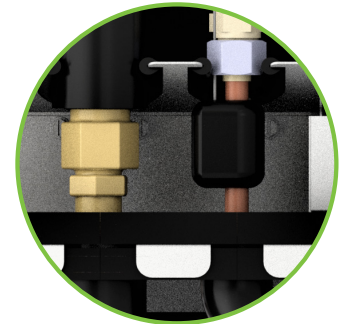

Disconnect couplings for refrigeration section

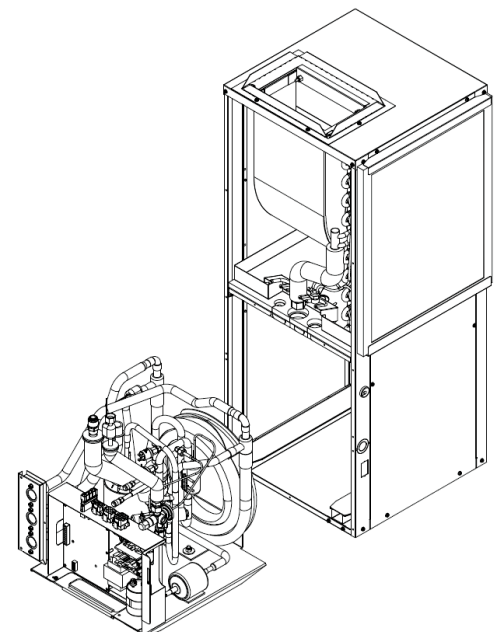
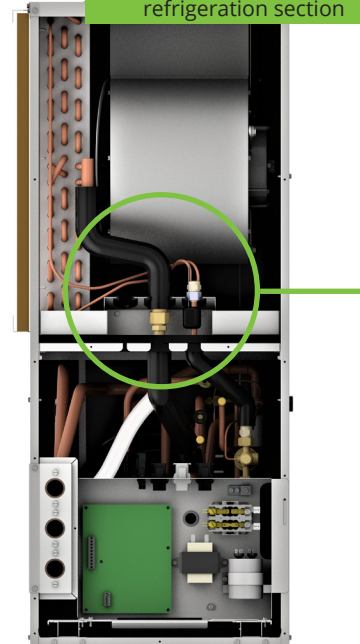

Slide out refrigeration section



PHYSICAL DATA

WSS6	6	9	12	15	18	24	29
Compressor (1 Each)	Rotary				Scroll		
Factory Charge (R454B) lbs [oz]	1.95 [31.2]	1.95 [31.2]	2.03 [32.5]	2.03 [32.5]	3.25 [52]	3.25 [52]	3.3 [52.8]
ECM Fan Motor & Blower	-	-	-	-	-	-	-
Blower Wheel Size (D x W)	9x7	9x7	9x7	9x7	10x7	10x7	10x7
PSC Fan Motor & Blower	-	-	-	-	-	-	-
Fan Motor Type	ECM	ECM	ECM	ECM	ECM	ECM	ECM
Motor HP	1/4	1/4	1/4	1/4	1/2	1/2	1/2
Water Connection Size FPT	3/4	3/4	3/4	3/4	3/4	3/4	3/4
Condensate Connection Size	3/4	3/4	3/4	3/4	3/4	3/4	3/4
Coax Volume (gallons)	0.43	0.43	0.43	0.43	0.14	0.14	0.14
Vertical	-	-	-	-	-	-	-
Air Coil Dimensions (H x W)	20x12	20x12	20x12	20x12	20x14	20x14	20x14
Filter Size	20x14	20x14	20x14	20x14	20x16	20x16	20x16
Weight - Operating (lbs)	153	155	157	159	211	213	215
Weight - Packaged (lbs)	158	160	162	164	216	218	220
FPT = Female Pipe Thread							

Data is subject to change. Please verify current information on www.ae-air.com.

PHYSICAL DATA

Unit Dimensions

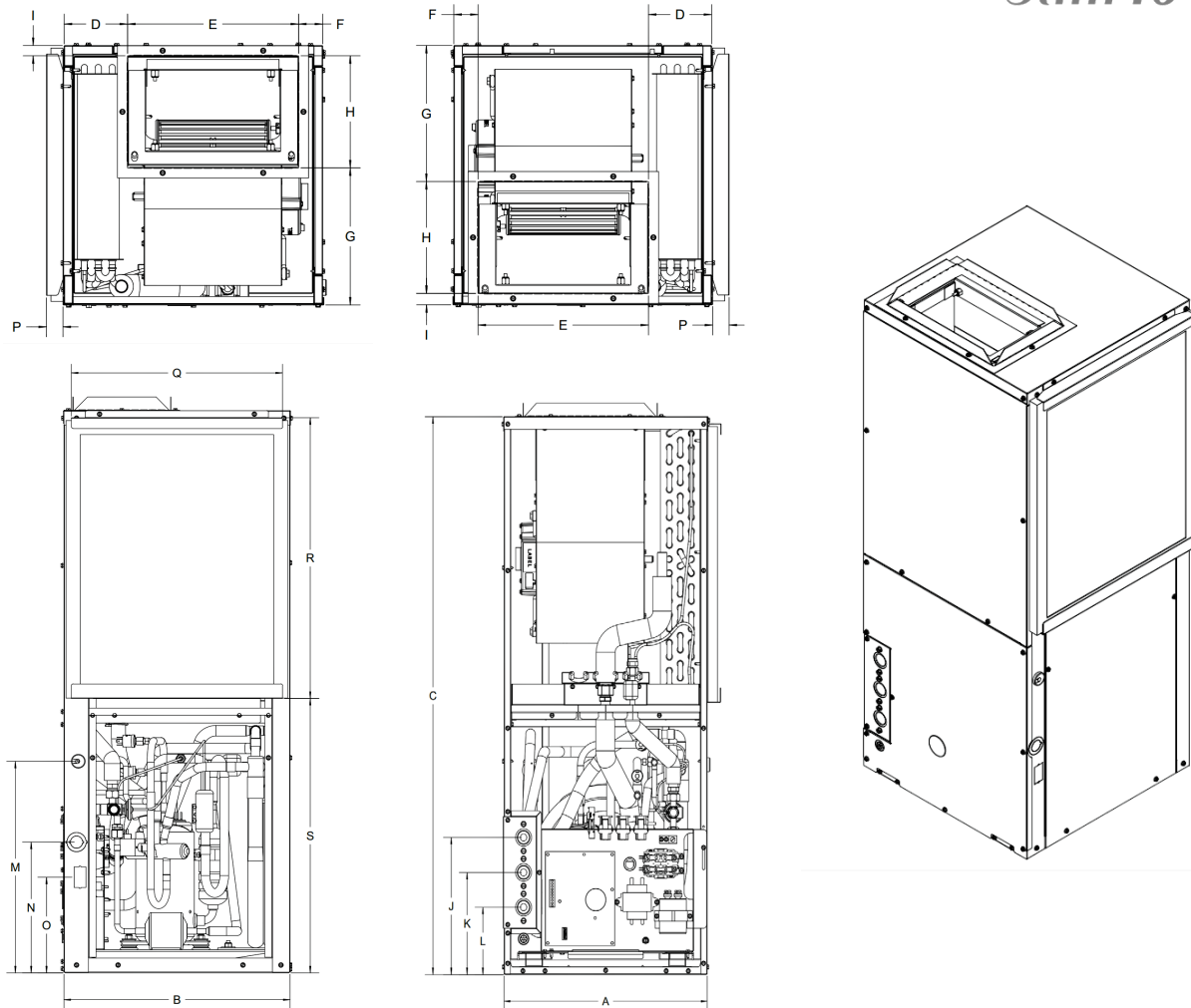

Model Number	Overall Cabinet Dimensions										
	A	B	C	D	E	F	G	H	I	J	K
WSS6006*	16	16	40	3-5/16	10-5/8	1-1/2	8-1/2	7	5/8	9-3/4	7-1/4
WSS6009*	16	16	40	3-5/16	10-5/8	1-1/2	8-1/2	7	5/8	9-3/4	7-1/4
WSS6012*	16	16	40	3-5/16	10-5/8	1-1/2	8-1/2	7	5/8	9-3/4	7-1/4
WSS6015*	16	16	40	3-5/16	10-5/8	1-1/2	8-1/2	7	5/8	9-3/4	7-1/4
WSS6018*	18	18	40	6	13	1-1/2	4-3/8	10-5/8"	5/8	9-3/4	7-1/4
WSS6024*	18	18	40	6	13	1-1/2	4-3/8	10-5/8"	5/8	9-3/4	7-1/4
WSS6030*	18	18	40	6	13	1-1/2	4-38	10-5/8"	5/8	9-3/4	7-1/4

Model Number	Overall Cabinet Dimensions (Cont.)							
	L	M	N	O	P	Q	R	S
WSS6006*	4-3/4	15	9-1/4	6-3/4	1	15	20	19-1/2
WSS6009*	4-3/4	15	9-1/4	6-3/4	1	15	20	19-1/2
WSS6012*	4-3/4	15	9-1/4	6-3/4	1	15	20	19-1/2
WSS6015*	4-3/4	15	9-1/4	6-3/4	1	15	20	19-1/2
WSS6018*	4-3/4	15	9-1/4	6-3/4	1	17	20	19-1/2
WSS6024*	4-3/4	15	9-1/4	6-3/4	1	17	20	19-1/2
WSS6030*	4-3/4	15	9-1/4	6-3/4	1	17	20	19-1/2

PERFORMANCE DATA

MODEL	V/Ph/Hz	NOM. CFM	GPM	WATER LOOP (entering Water Temperature)				GROUND WATER (entering Water Temperature)			
				86 Deg. F		68 Deg. F		59 Deg. F		50 Deg. F	
				COOLING	EER	HEATING	COP	COOLING	EER	HEATING	COP
WSS6006*	208-230-1/1/60	290	2	8000	17.0	8800	5.4	8600	26.0	7200	4.5
	265/1/60	290	2	8000	17.0	8800	5.4	8600	26.0	7200	4.5
WSS6009*	208-230-1/1/60	350	2.5	9000	16.0	10200	5.0	11200	26.0	8200	4.5
	265/1/60	350	2.5	9000	16.0	10200	5.0	11200	26.0	8200	4.5
WSS6012*	208-230-1/1/60	400	3	11800	16.5	14300	5.5	13800	26.0	10400	4.5
	265/1/60	400	3	11800	16.5	14300	5.5	13800	26.0	10400	4.5
WSS6015*	208-230-1/1/60	490	4	15000	15.0	18900	4.9	18100	23.1	15500	4.3
	265/1/60	490	4	15000	15.0	18900	4.9	18100	23.1	15500	4.3
WSS6018*	208-230-1/1/60	490	4.5	18300	16.8	19700	4.9	20700	27.0	16000	4.0
	265/1/60	490	4.5	18200	15.7	19300	4.3	20700	24.7	15700	3.7
WSS6024*	208-230-1/1/60	690	7	23800	16.7	28000	4.9	27300	25.0	23100	3.9
	265/1/60	690	7	23800	16.7	28000	4.9	27300	25.0	23100	3.9
WSS6030*	208-230-1/1/60	850	9	29100	15.1	33600	4.4	33000	23.3	28000	3.9
	265/1/60	850	9	29100	15.1	33600	4.4	33000	23.3	28000	3.9

AHRI/ISO 13256-1 conditions;

Cooling: Entering air = 80.6° DB / 66.2° WB (F)
 Entering fluid temperature = 86° (F)

Heating: Entering air = 68° DB (F)

Entering fluid temperature = 68° (F)
 DATA AT 208V

PRESSURE DROP (PSI):

Model	GPM	Entering Water Temperature °F					
		50	60	70	80	90	100
WSS6006*	0.8	0.6	0.6	0.5	0.5	0.5	0.5
	1.1	0.7	0.7	0.7	0.7	0.7	0.7
	1.5	0.9	0.9	0.9	0.9	0.9	0.9
WSS6009*	1.1	0.7	0.7	0.7	0.7	0.7	0.7
	1.7	1.3	1.1	0.9	0.7	0.5	0.3
	2.3	2.2	2.0	1.8	1.6	1.4	1.2
WSS6012*	1.5	0.9	0.9	0.9	0.9	0.9	0.9
	2.3	2.2	2.0	1.8	1.6	1.4	1.2
	3.0	3.4	3.2	3.0	2.8	2.6	2.4
WSS6015*	1.9	1.6	1.4	1.2	1.0	0.8	0.6
	2.8	3.1	2.9	2.7	2.5	2.3	2.1
	3.8	4.7	4.5	4.3	4.1	3.9	3.7
WSS6018*	2.3	1.1	0.9	0.8	0.7	0.6	0.5
	3.4	2.0	1.7	1.4	1.0	0.7	0.4
	4.5	3.0	2.7	2.3	2.0	1.7	1.3
WSS6024*	3.0	1.7	1.4	1.0	0.7	0.4	0.3
	4.5	3.0	2.7	2.3	2.0	1.7	1.3
	6.0	4.3	4.0	3.6	3.3	3.0	2.6
WSS6030*	3.6	2.3	1.9	1.6	1.2	0.9	0.6
	5.4	3.8	3.5	3.2	2.8	2.5	2.1
	7.3	5.4	5.1	4.7	4.4	4.1	3.7

Data is subject to change. Please verify current information on www.ae-air.com.

ELECTRICAL DATA

MODEL NUMBER	VOLTAGE PH-HZ	COMPRESSOR		BLOW		MCA	MCP
		RLA	LRA	FLA	HP		
WSS6006*	208/230V-1-60	3.0	15.0	2.3	1/4	7	15
	265V-1-60	2.7	11.0	2.3	1/4	6	15
WSS6009*	208/230V-1-60	4.4	22.0	2.3	1/4	8	15
	265V-1-60	3.5	22.0	2.3	1/4	7	15
WSS6012*	208/230V-1-60	4.7	26.0	2.3	1/4	9	15
	265V-1-60	3.8	23.0	2.3	1/4	8	15
WSS6015*	208/230V-1-60	6.3	32.0	2.3	1/4	11	15
	265V-1-60	5.6	27.0	2.3	1/4	10	15
WSS6018*	208/230V-1-60	9.0	47.5	4.1	1/2	16	20
	265V-1-60	7.1	43.0	4.1	1/2	13	20
WSS6024*	208/230V-1-60	10.9	62.9	4.1	1/2	18	25
	265V-1-60	9.0	54.0	4.1	1/2	16	20
WSS6030*	208/230V-1-60	13.5	72.5	4.1	1/2	21	30
	265V-1-60	11.2	60.0	4.1	1/2	19	25

Data is subject to change. Please verify current information on www.ae-air.com.

BLOWER DATA

MODEL NUMBER	FAN SPEED	STATIC PRESSURE					
		0.1	0.2	0.3	0.4	0.5	0.6
WSS6006*	T3	300	270	240	210	190	-
	T2	260	230	200	170	150	-
	T1	210	180	150	120	100	-
WSS6009*	T3	470	440	410	390	360	-
	T2	300	270	240	210	190	-
	T1	260	230	200	170	150	-
WSS6012*	T3	580	540	510	490	460	-
	T2	530	490	470	440	410	-
	T1	410	380	350	320	300	-
WSS6015*	T3	620	590	560	530	510	-
	T2	580	540	510	490	460	-
	T1	500	470	440	410	390	-
WSS6018*	T4	760	730	700	670	640	-
	T3	670	640	610	580	550	-
	T2	560	530	500	470	440	-
	T1	450	410	380	350	320	-
WSS6024*	T4	980	940	910	880	850	-
	T3	940	900	870	840	820	-
	T2	880	840	810	780	750	-
	T1	760	730	700	670	640	-
WSS6030*	T4	1150	1120	1090	1060	1030	-
	T3	1040	1010	970	950	920	-
	T2	980	940	910	880	850	-
	T1	880	840	810	780	750	-

NOTE:

- Airflow data shown is with a dry coil at 70°DB EAT with Standard 1" filter
- For superior dehumidification in the summer, all models operate at a slightly lower speed for a maximum of ten minutes before shifting to a higher speed. An optional "High" speed is available for higher static applications.

Data is subject to change. Please verify current information on www.ae-air.com.

GUIDE SPECIFICATIONS

General

Equipment shall be completely assembled, piped, internally wired, fully charged with R-454B refrigerant and test operated at the factory. Filters, thermostat field interface terminal strip, and all safety controls are furnished and factory installed. The system water inlet and outlet connections shall be female NPT panel-mounted - No back-up wrench needed. The 2.5-ton and below equipment shall contain ETL, CETL and ISO-ARI 13256-1 listings and labels prior to leaving the factory.

Air-to-Refrigerant Coil

Internally finned, 3/8-inch copper tubes mechanically bonded to a configured aluminum plate fin shall be standard. Coils shall be leak tested at the factory to ensure the pressure integrity. The coil shall be leak tested to 450 psig and pressure tested to 650 psig. The tubes are to be completely evacuated of air and correctly charged with proper volume of refrigerant prior to shipment. The refrigerant coil distributor assembly shall be of orifice style with round copper distributor tubes. The tubes shall be sized consistently with the capacity of the coil. Suction header shall be fabricated from rounded copper pipe. A thermostatic expansion valve shall be factory selected and installed for a wide range of control.

Reversing Valve

A system reversing valve (4-way valve) is included with all heating/cooling units. This valve is piped to be energized in the cooling mode to allow the system to provide heat if valve failure were to occur. Once the valve is energized for cooling, it will remain energized until the control system is turned to the OFF position, or a heating cycle is initiated. Units with the cooling only option will not receive a reversing valve.

Automatic Flow Devices (option)

The automatic flow kit shall contain a Hays Mesurflo® automatic flow control valve, two ball valves, two flexible hoses, a high flow Y-strainer, and may include a strainer blow-down and various other accessories. The automatic flow control valve shall be factory set to a rated flow, and shall automatically control the flow to within 10% of the rated value over a 40 to 1 differential pressure, operating range (2 to 80 PSID). Operational temperature shall be rated from fluid freezing, to 225°F. The valve body shall be constructed from hot forged brass UNS C37700 per ASTM B-283 latest revision. For more information pertaining to the automatic balancing hose kits, see literature documentation .

Ball Valves (option)

Ball valves shall be field installed between the unit and the supply and return lines of the loop to stop water flow to the unit in a maintenance or service situation.

Cabinet

Fabricated from a minimum of 18 gauge galvanized steel with a durable baked-on powder coat finish. Post and panel construction allows for large access panels to permit full access to internal components. The structural integrity of the cabinets shall remain unaffected by the removal of any or all access panels. All panels shall be insulated with high density close cell foam, which offers greater sound absorption and better thermal efficiency. The insulation meets the erosion requirements of UL 181. It has a flame spread of less than 25 and a smoke developed classification of less than 50 per ASTM E-84 and UL 723. Access for inspection and cleaning of the unit drain pan, coils and fan section shall be provided. The unit shall be installed for proper access.

Compressors

Unit contains a high efficiency rotary or scroll compressor. Compressor mounting shall be double isolated with rubber mounts to prevent excessive vibration and noise through the system. Internal thermal overload protection is provided. Protection against excessive discharge pressure is provided by means of a high pressure switch. A loss of charge sensor is provided by a low pressure safety.

Basic Controls

Units shall include the following controls and functions: Service test mode with diagnostic LED shall allow service personnel to check the operation of the WSHP and control system efficiently. Upon entering Test mode, time delays speed up, and the Status LED displays a code to indicate the last fault experienced. This mode provides easy fault diagnosis; based on the fault code that the status LED displays.

24V Status LED - Green light indicates 24V power to the control module.

VPC (Vacated Premises Control) - Shall allow the unit to operate for either 1 or 2 hours per day (total) during extended periods of no occupancy. (requires optional kit).

Nuisance Trip Protection - Unit will attempt to start up to three times with a fault signal. If the fault continues, the unit locks out.

Condensate overflow lock-out, an electronic sensor mounted to the drain pan. When condensate pan liquid reaches an unacceptable level, the unit is automatically deactivated and placed in a lockout condition.

High and Low Pressure Switches

Condenser coil low temperature protection, high / low voltage protection because of high or low voltage conditions.

Random re-start timer to ensure a random delay in energizing each different WSHP unit to minimize peak electrical demand during start-up from different operating modes or after building power outages. Provide the circuit board with conformal coating (both sides of board) for humidity and condensation protection.

Provide Anti-short Cycle Timer, Alarm Relay - Activated if the unit locks out.

Field selectable settings:

5 Second Compressor Delay - Blower starts before the compressor, attenuates compressor start up sound.

45 Second Blower-off Delay - Increases cooling efficiency.

Continuous Dehumidification Mode - Selects continuous low speed fan operation for increased humidity removal.

Provide the following, low water temperature and low coil temperature cutout options-Optional 10 degree F. cutouts for applications where water temperature is below 50 degrees F. (requires antifreeze solution).

Accessory Relays (2) - Relays can be selected to cycle with either the fan or compressor.

Relay "1" can be configured for use with slow opening water valves (60 second pre-compressor initialization) and relay "2" can be configured for a 30 second post fan delay.

Drain Pan

The condensate pan shall be constructed of corrosion proof material. The bottom of the drain pan shall be sloped on two planes which pitches the condensate to the drain connection. The drain pan shall be flame rated per UL945V-B.

GUIDE SPECIFICATIONS (CONT.)

Electrical

The unit control box shall contain all necessary devices to allow heating and cooling operation to occur from a remote wall thermostat. These devices shall be as follows:

24 VAC energy limiting class II [50 VA (minimum) transformer]

24 VAC blower motor relay

24 VAC compressor contactor for compressor control

Thermostat connections shall be provided for ease of hook-up to a terminal strip located in the unit's control box.

Electric Heat (option)

Boiler-less control electric heat shall be field supplied and wired to WSHP control panel. It shall be composed of a nichrome open wire coil designed for 2-kW per unit ton. The design consist of a single stage of electric heat used as a primary heating source when compressor lockout has occurred due to the entering water temperature falling below 55°F with an adjustable range between 25°F to 60°F. The electric heat option is not intended for secondary heat.

Filters

One inch filters shall be standard and factory installed.

Hoses (option)

Hoses shall consist of a stainless steel outer braid with an inner core of tube made of a nontoxic synthetic polymer material. The hoses shall be suitable for water temperatures ranging between 33°F and 211°F without the use of glycol.

Indoor Blower

Wheels are double width, double inlet (DWDI), forward curved, centrifugal type. They are statically and dynamically balanced for a smooth, quiet operation. The Class I housing is constructed of heavy gauge steel with die-formed inlet cones.

Motors to be multi-speed, 230V, single phase, 60-Hz, permanent split capacitor (PSC) type, factory mounted to the blower assembly with rubber isolators.

Motorized Water Valve (option)

When extreme fluid temperature conditions do not exist with an open loop system, a motorized water valve shall be applied to each water-source heat pump. The motorized valve shall stop flow to the unit, causing pressures to rise. This rise in pressure will halt pump operation to provide greater energy savings of the entire system.

Pump Module (option)

The pump module shall be a complete self contained pumping package for an earth-coupled heat pump system. The module shall consist of a single bronze pump, and a brass 3-way shut-off valve. These kits shall contain the necessary components for the installation, operation, and maintenance of the water circuit of a closed-loop distributed pumping application.

Refrigerant Circuits

The refrigerant circuit shall contain a thermal expansion device (TXV). Service pressure ports shall be factory supplied on the high and low pressure sides for easy refrigerant pressure or temperature testing.

Refrigeration Pack

All units shall come with a removable condensing section that contains the compressor, coaxial heat exchanger, TXV and reversing valve. The condensing section shall be removable from the unit using torch-less mechanical fittings to allow for extraction for repair.

Refrigerant Tubing

The refrigerant tubing shall be copper. This system shall be free from contaminants and conditions such as drilling fragments, dirt and oil. Coaxial Heat Exchanger features a tube-in-tube coaxial water-to-refrigerant heat exchanger and constructed of a convoluted copper (optional cupronickel) inner tube and steel outer tube with a designed refrigerant working pressure of 450 PSIG (3100 kPa) and designed water side working pressure of no less than 400 PSIG (2750 kPa).

Serviceability Access

All unit shall have service access to the electrical box, TXV, reversing valve, high and low pressure from the unit.

GUIDE SPECIFICATIONS (CONT.)

Control Module and Safety Devices:

The WSS* unit comes standard with a control module that controls the units operation and monitors the safety controls that protect the compressor, heat exchanger, wiring and other components from damage caused by operating outside of design conditions.

Safety controls include the following:

- High pressure switch located in the refrigerant discharge line.
- Low pressure switch located in the refrigerant suction line.
- Water coil low temperature cutout sensor located on the heat exchanger to prevent unit operation below low temperature setting.
- Condensate overflow protection sensor located in the drain pan.
- The control module includes the following features:
- Anti-Short Cycle Timer - 5 minute anti-short cycle protection for the compressor.

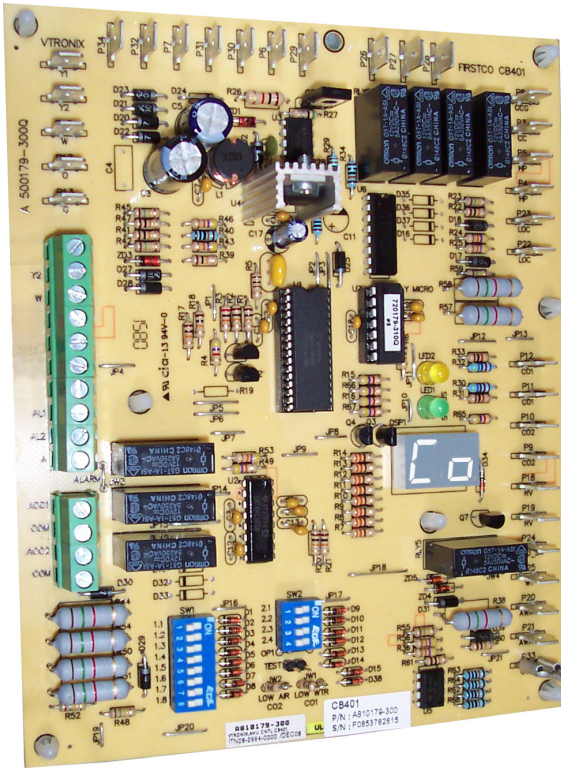

Electronic Control Module



Optional Vacated Premises Selector Switch (Kit# 9WS01)

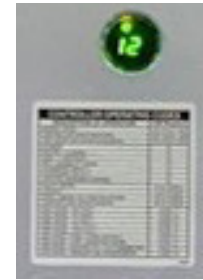

Sight glass on door

NOTE: THE 5 MINUTE ANTI-SHORT CYCLE ALSO OCCURS AT POWER UP.

- Random Start - The controller features a 5-80 second random start upon power up.
- Low Pressure Bypass Timer - The low pressure switch input is bypassed for the initial 120 seconds of a compressor run cycle to prevent nuisance low pressure lockouts.
- Over / Under Voltage Shutdown - Should a Over / Under Voltage condition be detected, the module will initiate a shutdown.

Over / Under Voltage Shutdown is self resetting in that if the voltage comes back with range of 18.5VAC to 31VAC, then normal operation will be restored.

- Alarm Relay - The module has a set of contacts for remote fault indication. Contacts can be 24VAC output or converted to a dry contact.
- Test Mode - Test pins can be momentarily jumpered to enter into a 10-minute test mode period in which all time delays are sped up to 15 times. While in the test mode the LED Display will display a code representing the last fault in memory.

NOTE: CONTINUED OPERATION OF THE UNIT IN THE TEST MODE CAN LEAD TO ACCELERATED WEAR AND PREMATURE FAILURE OF UNIT.

- Fault Retry - While in the fault retry mode, the LED Display will display a code representing retry and the fault code. The unit will initiate the anti-short cycle timer and try to restart after the delay. If 3 consecutive faults occur without satisfying the thermostat, the control will go to lockout mode. The last fault causing the lockout will be stored in memory and displayed.
- Lockout - While in the lockout mode, the LED Display will display a code representing lockout and the fault code. The compressor relay is turned off immediately. During a lockout mode the alarm relay is activated. Lockout mode can be soft reset by turning the thermostat to the "OFF" position then back to the "HEAT" or "COOL" mode or hard reset via the power disconnect.
- LED Indication - Two LED indicators are provided as follows:
 - Green: Power LED indicates 18.5 - 31 VAC is present at the board.
 - Yellow: Test LED indicates the unit is operating the test mode.
- LED Display - A two digit display indicates the system mode and fault code, if present.



AE-Air
P.O. Box 270969 - Dallas, Texas 75227
Ph. (214) 388-5751 | Fax (214) 388-2255
www.ae-air.com

MAY 2024