



WSVC

Water Source Heat Pump



Vertical

3/4 thru 5 Tons



R454B

NOMENCLATURE

WSVC 024 D 2 L C F T 0 0 0 0 0 000 A

MODEL

WSVC - R454B VERTICAL
 WSVX - R454B VERTICAL ECM
 WSHC - R454B HORIZONTAL
 WSHX - R454B HORIZONTAL ECM

CAPACITY

E06 - 6,000 Btuh (WSHC/WSHX Low Profile 11")
 E09 - 9,000 Btuh (WSHC/WSHX Low Profile 11")
 E12 - 12,000 Btuh (WSHC/WSHX Low Profile 11")
 009 - 9,000 Btuh
 012 - 12,000 Btuh
 018 - 18,000 Btuh
 024 - 24,000 Btuh
 030 - 30,000 Btuh
 036 - 36,000 Btuh
 040 - 40,000 Btuh
 042 - 42,000 Btuh
 048 - 48,000 Btuh
 060 - 60,000 Btuh

REVISION

D - R454B Initial Release

VOLTAGE

2 - 208-230V/1Ph/60Hz (PSC)
 3 - 265V/1Ph/60Hz (PSC)
 6 - 208-230V/1Ph/60Hz (ECM)
 7 - 265V/1Ph/60Hz (ECM)
 E - 208-230V/3Ph/60Hz (PSC)
 F - 460V/3Ph/60Hz (PSC) (WSHC/WSHX) (Does not include 11" Unit)
 M - 208-230V/3Ph/60Hz (ECM)
 N - 460V/3Ph/60Hz (ECM) (WSHC/WSHX) (Does not include 11" Unit)

RETURN LOCATION

L - Left Hand
 R - Right Hand

HEAT EXCHANGER

C - Copper
 N - Cupro-Nickel

WATER CIRCUIT OPTIONS

F - Front

FACTORY

A - AE-Air

OPTION

000 - None

INSULATION

0 - Fiberglass Standard Insulation
 A - Closed Cell Foam
 B - Foil Faced Insulation
 C - Compressor Jacket
 S - Closed Cell + Compressor Jacket

REHEAT

0 - None

CONTROLS

0 - Standard Controls
 A - Standard with Service Switch

FILTER TYPE

0 - 1" Throwaway Standard
 A - 2" MERV 8
 B - 2" MERV 11
 C - 2" MERV 13
 D - 4" MERV 11
 E - 4" MERV 13
 F - 4" MERV 14
 G - 1" MERV 8
 H - 1" MERV 11
 J - 1" MERV 13
 K - Permanent + 4" MERV 11
 L - Permanent + 4" MERV 13
 M - Permanent + 4" MERV 14

FILTER FRAME

0 - 1" 2-Sided (WSHC/WSHX E06,E09, E12 Low Profile 11")
 1 - 1" 4-Sided (WSHC/WSHX E06,E09, E12 Low Profile 11")
 2 - 1" + 2" 4-Sided (WSHC/WSHX E06,E09, E12 Low Profile 11")
 0 - 1" + 2" 2-Sided (WSVC/WSVX/ WSHC/WSHX 009-060)

SUPPLY AIR LOCATION

E - End
 S - Straight
 T - Top (Vertical Only)

WSVC

WATER SOURCE HEAT PUMP

The **WSVC** includes many standard features found only in higher priced products, plus a number of unique features including:

- Having the **smallest footprint** of any product in its class ensures a perfect fit when replacing older models in tight closets, even the 036 model is only 21.5 wide by 21.5 deep.
- **Blower assemblies are field-reversible** 180 degrees. This option can improve airflow when the units are installed in closets with very little room for supply plenums.
- Optional **Vacated Premises Control (VPC)** kit with reset feature: Ensures that the unit will operate a minimum of one or two hours per day during extended periods of unoccupancy. This option also includes an automatic reset feature. If a fault occurs, the system will shut down, but then automatically reset every 24 hours. If the same fault exists each day, the unit will lockout on the fourth day and have to be manually reset.
- **Superior insulation:** Fully insulated with $\frac{3}{4}$ " Tuf-Skin RX™, which offers greater sound absorption and better thermal efficiency. The insulation has a special acrylic coating formulated with an EPA registered anti-microbial agent.
- **Removable discharge flange:** Provides additional installation clearance.
- **Tool-less filter rack installation:** Can be installed after the unit is in the closet, providing additional installation clearance.
- State-of-the-art **Digital Control Module**



STANDARD FEATURES

- Digital Diagnostic Display - A two-digit display indicates either the current operational mode or a fault code
- 24V Status LED - Green light indicates 24V power to the control module
- VPC (Vacated Premises Control) - Allows the unit to operate for either 1 or 2 hours per day (total) during extended periods of unoccupancy (requires optional kit).
- Nuisance Trip Protection - Unit will attempt to start up to three times with a fault signal. If the fault continues, the unit locks out.
- Condensate Overflow Lockout
- High and Low Pressure Controls
- Water Coil Low Temperature Protection
- Over / Under Voltage Protection
- Random Re-start Timer
- Anti-short Cycle Timer
- Test Mode With LED Indicator - Speeds up control timers for service personnel
- Alarm Relay - Activated if the unit locks out
- Conformal Coating (both sides) for humidity and condensation protection

DIP SWITCHES (FIELD SELECTABLE SETTINGS)

- 5 Second Compressor Delay - Blower starts before the compressor, which helps attenuate compressor start up sound.
- 45 Second Blower-off Delay - Increases cooling efficiency.
- Continuous Dehumidification Mode - Selects continuous low speed fan operation for increased humidity removal.
- VPC Switch - Selects either one or two hour daily operation (requires optional kit).
- Lower Water and Air Coil Temperature Cutout Options - Optional 10°F. cutouts for applications where water temperature is below 50°F. (requires antifreeze solution).
- Two Accessory Relays - The relays can cycle with either the fan or compressor. In addition, relay number one can be configured for use with slow opening water valves (60 second pre-compressor initialization) and relay number 2 can be configured for a 30 second post fan delay.

ADDITIONAL STANDARD FEATURES

- 100% factory tested
- R-454B Refrigerant - All units operate with environmentally friendly R-454B refrigerant.
- Non-corrosive Thermoplastic Condensate Pan- sloped for positive drainage
- High and low pressure service ports
- Refrigerant filter-dryer
- Panel-mounted FPT water connections - No back-up wrench needed.
- Removable panels for service
- 50 VA transformer
- 1" in throwaway filter

OPTIONAL FEATURES

- Cupronickel coaxial heat exchanger
- Vacated premises control
- E-Coated air coil corrosion protection
- Compressor cover: a heavy duty, insulated compressor cover that reduces unwanted compressor noise (must be field installed on the WSVX unit before the unit is installed in the closet).
- Part No. K3821332 (fits WSVX18-42)
- Part No. K4251 (fits WSVX48/60)
- Evaporator temperature sensor

DIGITAL CONTROL MODULE

- Controls unit operation and monitors all safety controls. (Patent Pending)

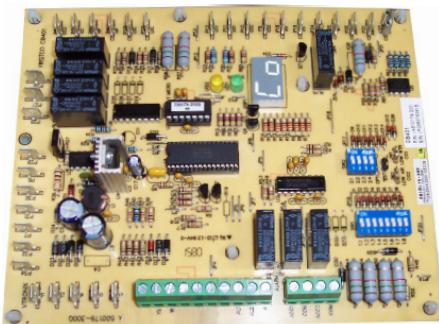

Electronic Control Module



Thermoplastic Drain Pan



Optional Vacated Premises Selector Switch
(Kit# 9WS01)

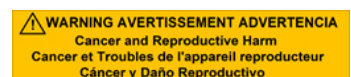

ELECTRICAL DATA

MODEL NUMBER	VOLTAGE	COMPRESSOR		BLOWER		MIN. CIRCUIT AMPACITY	MAX. CIRCUIT PROTECTION
		RLA	LRA	FLA	HP		
WSVC009	208/230V-1-60	3.7	22	0.6	1/12	6	15
WSVC012	208/230V-1-60	4.7	25	0.7	1/10	7	15
WSVC018	208/230V-1-60	9	56	0.9	1/8	13	20
	265V-1-60	7.1	43	0.9	1/8	10	15
WSVC024	208/230V-1-60	10.9	63	1.6	1/6	16	25
	265V-1-60	9	54	1.4	1/6	13	20
WSVC030	208/230V-1-60	12.8	68	3.1	1/2	20	30
	265V-1-60	10.9	60	2.7	1/2	17	25
WSVC036	208/230V-1-60	15.4	84	3.1	1/2	23	35
	265V-1-60	13.5	72	2.7	1/2	20	30
	208/230V-3-60	10.4	73	3.1	1/2	17	25
	460V-3-60	5.8	38	1.6	1/2	9	15
WSVC042	208/230V-1-60	19.2	124	3.1	1/2	28	45
	208/230V-3-60	13.5	88	3.1	1/2	20	30
	460V-3-60	6	44	1.6	1/2	10	15
WSVC048	208/230V-1-60	19.6	130	3.5	1/2	28	45
	208/230V-3-60	13.7	83	3.5	1/2	21	30
	460V-3-60	6.2	41	1.4	1/2	10	15
WSVC60	208/230V-1-60	24.4	144	5.7	3/4	37	60
	208/230V-3-60	16	110	5.7	3/4	26	40
	460V-3-60	7.8	52	2.4	3/4	13	15

Data is subject to change. Please verify current information on www.ae-air.com.

PERFORMANCE DATA

PERFORMANCE DATA - AT STANDARD OPERATING CONDITIONS						
MODEL	NOM. CFM	GPM	WATER LOOP (Entering Water Temperature)			
			85 Deg. F		70 Deg. F	
			COOLING	EER	HEATING	COP
WSVC009D	300	2.3	7,600	13.4	9,300	4.30
WSVC012D	340	3.0	11,600	13.4	13,400	4.30
WSVC018D	550	5.0	17,200	13.1	22,300	4.30
WSVC024D	680	6.0	22,700	13.1	28,280	4.30
WSVC030D	930	7.5	28,050	13.2	34,230	4.30
WSVC036D	970	9.1	33,150	13.2	42,300	4.30
WSVC042D	1250	10.7	40,970	13.1	49,600	4.30
WSVC048D	1400	12.0	47,610	13.6	55,550	4.30
WSVC060D	1760	15.0	56,610	13.4	70,120	4.30

Note: Tabulated performance data is at noted entering water temperature and entering air conditions of 80 degree DB / 67 degree WB for cooling and 70 degree DB for heating at 208V CFM.

PERFORMANCE DATA						
MODEL	NON CFM	GPM	WATER LOOP (Entering Water Temperature)			
			86 DEG. F		68 DEG. F	
			COOLING	EER	HEATING	COP
WSVC009D	300	2.6	7,500	13.30	9,200	4.30
WSVC012D	340	3.0	11,500	13.30	13,200	4.30
WSVC018D	550	5.0	17,100	13.00	22,100	4.30
WSVC024D	680	6.0	22,500	13.00	28,000	4.30
WSVC030D	930	7.5	27,800	13.00	33,900	4.30
WSVC036D	970	9.1	33,000	13.00	41,900	4.30
WSVC042D	1250	10.7	40,500	13.00	49,000	4.30
WSVC048D	1400	12.0	47,100	13.60	54,900	4.30
WSVC060D	1760	15.0	56,000	13.30	69,400	4.30

Note: Tabulated performance data is at noted entering water temperature and entering air conditions of 80.6 degree DB / 66.2 degree at 208V CFM

Data is subject to change. Please verify current information on www.ae-air.com.

BLOWER DATA

MODEL NUMBER	FAN SPEED	CFM vs EXTERNAL STATIC PRESSURE (inches of water)					
		0.1	0.2	0.3	0.4	0.5	0.6
WSVC009D	HIGH	440	390	310	---	---	---
	MED	330	300	220	---	---	---
WSVC012D	HIGH	490	460	430	400	---	---
	MED	370	350	330	310	---	---
WSVC018D	HIGH	835	790	730	670	610	540
	MED	710	670	620	560	510	---
	LOW	580	535	490	---	---	---
WSVC024D	HIGH	910	860	800	730	650	560
	MED	800	770	720	660	590	---
	LOW	650	620	590	550	490	---
WSVC030D	MED - HIGH	1160	1100	1030	950	870	780
	MED - LOW	1080	1030	960	890	820	---
	LOW	1000	950	890	830	760	---
WSVC036D	HIGH	1300	1230	1160	1090	1010	930
	MED - HIGH	1220	1160	1100	1040	960	---
	MED - LOW	1100	1060	1010	950	890	---
WSVC042D	HIGH	1750	1720	1680	1620	1550	1460
	MED - HIGH	1530	1510	1480	1450	1390	---
	MED - LOW	1260	1250	1230	1220	1200	---
WSVC048D	HIGH	1810	1780	1740	1660	1580	1490
	MED	1680	1660	1640	1590	1530	---
	LOW	1560	1550	1540	1510	1460	---
WSVC060D	HIGH	2160	2090	2010	1940	1830	1730
	MED	2030	1970	1900	1830	1750	---
	LOW	1830	1800	1740	1680	1610	---

Data is subject to change. Please verify current information on www.ae-air.com.

BLOWER DATA

Continued

MODEL NUMBER	SPEED vs. 0.1 EXT. STATIC H2O	DUCTED DISCHARGE						
		OCTAVE BAND FREQUENCY, Hz						
		125	250	500	1000	2000	4000	8000
WSVC018D*	High Speed	40.8	45.3	56.5	59.1	52.8	52.3	44
	Med. Speed	37.4	43.6	52.7	55.2	49.1	48.3	38.7
	Low Speed	33.1	40.8	47.6	50.2	44.3	42.2	31.3
WSVC024D*	High Speed	46.7	49.2	59.7	63.7	58.4	57.8	50.3
	Med. Speed	46.1	46.8	56.6	60.2	55	54.1	46
	Low Speed	42.4	43.5	51.6	55	49.8	48.5	38.7
WSVC030D*	High Speed	48.5	56.7	64.5	72.2	65.9	65.2	58.6
	Med. High Speed	48.3	53.9	64.2	71.2	64.9	64	57.5
	Med. Low Speed	46.8	52.2	63	68.9	63	62.2	55.7
	Low Speed	44.6	50.1	61.3	65.5	60.1	59.2	52.3
WSVC036D*	High Speed	50.6	58	67.1	73.2	68.9	67.2	60.4
	Med. High Speed	49.6	56.2	66.1	71.5	67.2	65.7	58.8
	Med. Low Speed	47.6	53.4	63.8	68.9	64.6	62.9	55.8
	Low Speed	44.7	50.3	61	64.9	60.6	58.8	51.5
WSVC042D*	High Speed	47.2	54.5	62.5	69.5	65	64.7	59
	Med. High Speed	41.2	48.9	57.2	62.3	58.2	57.5	51.2
	Med. Low Speed	37.3	44.5	51.7	55.9	52	50.7	43
	Low Speed	33.5	42.3	47.2	51.6	47.4	45.5	36.4

CASE RADIATED						
OCTAVE BAND FREQUENCY, Hz						
125	250	500	1000	2000	4000	8000
46.4	44.6	54.6	47.2	42.2	38.8	31.6
45.6	42.5	51	43.5	38.7	35.2	27.4
42.3	39.3	44.6	38.5	34.1	30.2	23.5
55.8	47.9	55.3	52.8	48.2	43.5	36.4
55.4	43.8	50	46.6	41.9	37.4	30.2
57.6	42.1	49.8	44	39.7	34.9	26.5
52.6	55.3	58.4	59.6	55.3	51.2	44.6
51.9	52.2	58	58.8	54.2	50.2	43.6
51.6	50.5	57	56.6	52.3	48.3	41.8
50.1	48.1	55.8	53.4	49.5	45.5	38.7
54.4	54.8	61.3	60.2	57.4	52.7	45.7
52.8	51.7	57.5	56.2	53.2	48.3	41.7
53.5	50.5	57.5	55.4	52.4	47.4	40.8
52.9	47.4	55.1	52.4	49.3	44.5	37.1
51.7	52	58.6	58	53.6	48.2	44
52.1	47.4	54.2	51.1	46.6	41.1	36.7
47.8	43.5	49.1	44.8	40.5	34.9	29.7
46.6	41.2	44.7	40.3	36.5	31.1	24.9

Data is subject to change. Please verify current information on www.ae-air.com.

DIMENSIONAL DATA

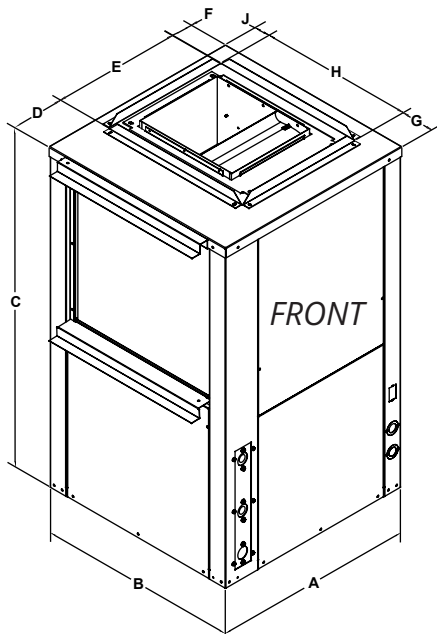

LEFT HAND UNIT

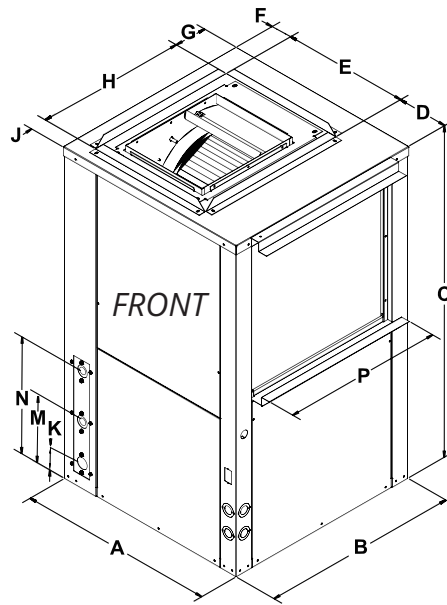

RIGHT HAND UNIT

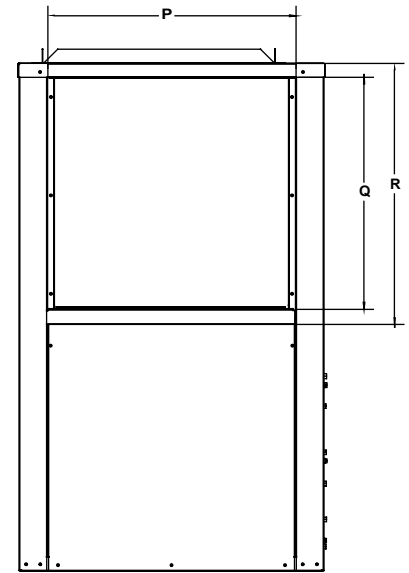

SIDE VIEW

MODEL NUMBER	A	B	C	D	E	F	G	H	J
	Width	Depth	Height		Duct			Duct	
WSVC009D*	21.50	21.50	28.25	9.38	8.00	4.25	4.38	13.00	4.25
WSVC012D*	21.50	21.50	28.25	9.38	8.00	4.25	4.38	13.00	4.25
WSVC018D*	21.50	21.50	36.25	5.50	13.75	2.25	3.63	16.25	1.75
WSVC024D*	21.50	21.50	36.25	5.50	13.75	2.25	3.63	16.25	1.75
WSVC030D*	21.50	21.50	39.25	5.50	13.75	2.25	3.63	16.25	1.75
WSVC036D*	21.50	21.50	39.25	5.50	13.75	2.25	3.63	16.25	1.75
WSVC042D*	21.50	26.00	43.25	5.00	15.75	0.75	5.00	16.25	4.75
WSVC048D*	26.00	26.00	43.25	7.12	17.88	1.00	5.00	17.88	3.13
WSVC060D*	26.00	26.00	43.25	7.12	17.88	1.00	5.00	17.88	3.13

MODEL NUMBER	K	M	N	P	Q	R	CONDENSER WATER CONNECTIONS	CONDENSATE CONNECTIONS	NOM. FILTER SIZE
	WATER IN	CONDENSATE DRAIN	WATER OUT	R/A DUCT FLANGE WIDTH	R/A DUCT FLANGE HEIGHT	FILTER RACK HEIGHT			
WSVC009D*	21.75	7.25	12.75	17.50	8.25	10.25	3/4" F.P.T	3/4" F.P.T	10 X 18 X 1
WSVC012D*	21.75	7.25	12.75	17.50	8.25	10.25	3/4" F.P.T	3/4" F.P.T	10 X 18 X 1
WSVC018D*	21.75	7.25	12.75	17.50	16.00	18.00	3/4" F.P.T	3/4" F.P.T	18 X 20 X 1
WSVC024D*	21.75	7.25	12.75	17.50	16.00	18.00	3/4" F.P.T	3/4" F.P.T	18 X 20 X 1
WSVC030D*	21.75	7.25	12.75	17.50	18.00	20.00	3/4" F.P.T	3/4" F.P.T	20 X 20 X 1
WSVC036D*	21.75	7.25	12.75	17.50	18.00	20.00	3/4" F.P.T	3/4" F.P.T	20 X 20 X 1
WSVC042D*	21.75	7.25	12.75	22.00	22.00	24.00	3/4" F.P.T	3/4" F.P.T	24 X 24 X 1
WSVC048D*	21.75	6.25	10.75	22.00	28.00	30.00	1" F.T.P	3/4" F.P.T	24 X 30 X 1
WSVC060D*	21.75	6.25	10.75	22.00	28.00	30.00	1" F.T.P	3/4" F.P.T	24 X 30 X 1

NOTES:

1. Right Hand and Left Hand return air is determined by facing the front of the unit.



AE-Air
P.O. Box 270969 - Dallas, Texas 75227
Ph. (214) 388-5751 | Fax (214) 388-2255
www.ae-air.com

MAY 2024