



# HRCX-FHR Single Stage Series

*Commercial Water Source Heat Pump*

**HydroTech**<sup>™</sup>  
**R-410A** Water Source Heat Pump

VERTICAL HI-RISE

SIZES 009-036 (3/4 - 3 TONS)

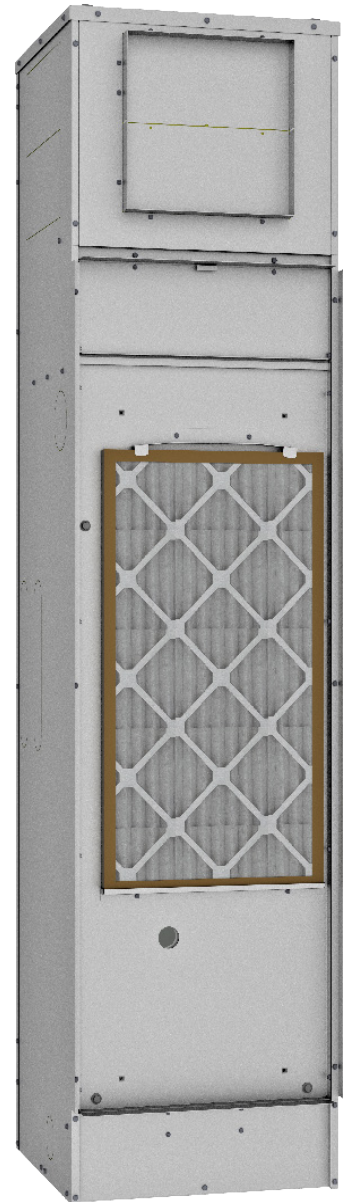

\* only applies to HRCX

# HRCX-FHR Series

## COMMERCIAL WATER SOURCE HEAT PUMP

### MODEL NOMENCLATURE

Cabinet – HydroTech High Rise

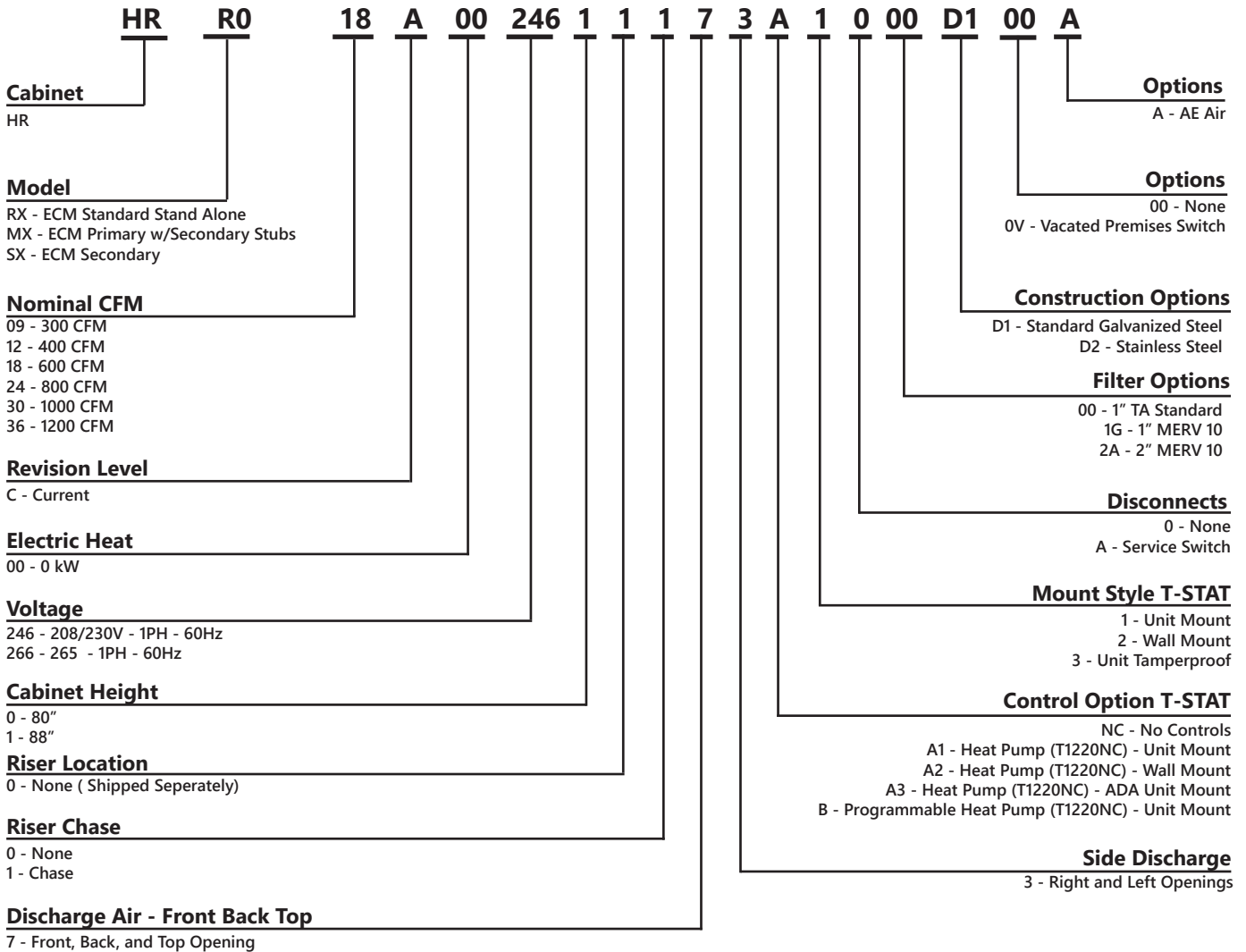

# HRCX-FHR Series

## COMMERCIAL WATER SOURCE HEAT PUMP

### MODEL NOMENCLATURE

Chassis – HydroTech High Rise

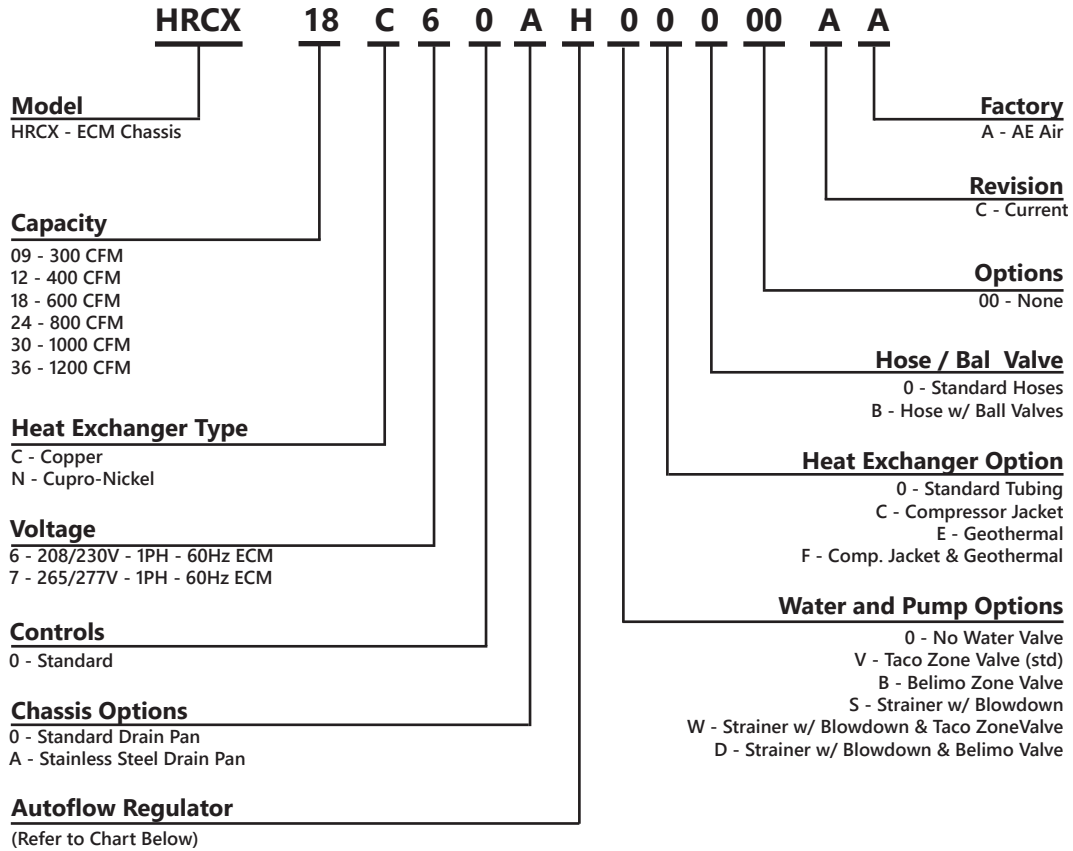

Auto-Flow Regulator (GPM) Code						
Tube Unit	5/8" Sweat		7/8" Sweat			
	09	12	18	24	30	36
0	0	No Flow Regulator				
C	1.5	1.5				
D	2.0	2.0	2.0			
E	2.5	2.5	2.5			
F	3.0	3.0	3.0	3.0		
G	3.5		3.5	3.5		
H	4.0			4.0	4.0	
I	4.5			4.5	4.5	
J	5.0			5.0	5.0	5.0
K	5.5				5.5	5.5
L	6.0				6.0	6.0
M	6.5				6.5	6.5
N	7.0				7.0	7.0
P	7.5					7.5
Q	8.0					8.0
T	9.0					9.0
V	10.0					10.0

# HRCX-FHR Series

## COMMERCIAL WATER SOURCE HEAT PUMP

# Vertical Hi-Rise

**Available sizes** for the vertical high-rise water-source heat pumps are 3/4-ton through 3-ton. Units are floor mounted and designed to be furred in behind drywall to blend into the space. Units consist of separate components - cabinet behind finished wall and slide in refrigeration chassis.

**For multi-story building applications**, the units may be stacked above each other by floor to minimize piping and electrical cost. Copper piping risers can be factory mounted to the rear or sides of the cabinet or can be fabricated and shipped in advance so the riser columns can be completely assembled, pressured tested, filled, and water circulated. This allows floor by floor completion and occupancy before the building is complete.

**The high-rise configuration** is often used in hotels, dorms and assisted living facilities where a single unit could provide comfort to a single or multiple room dwelling. Because the units are mounted directly in the space, ductwork is optional.

**All water-source heat pumps** are run tested with water and quality certified prior to leaving the factory. This assures quality standards from controls, water, refrigeration, and aesthetics to the building owner and installing contractor.

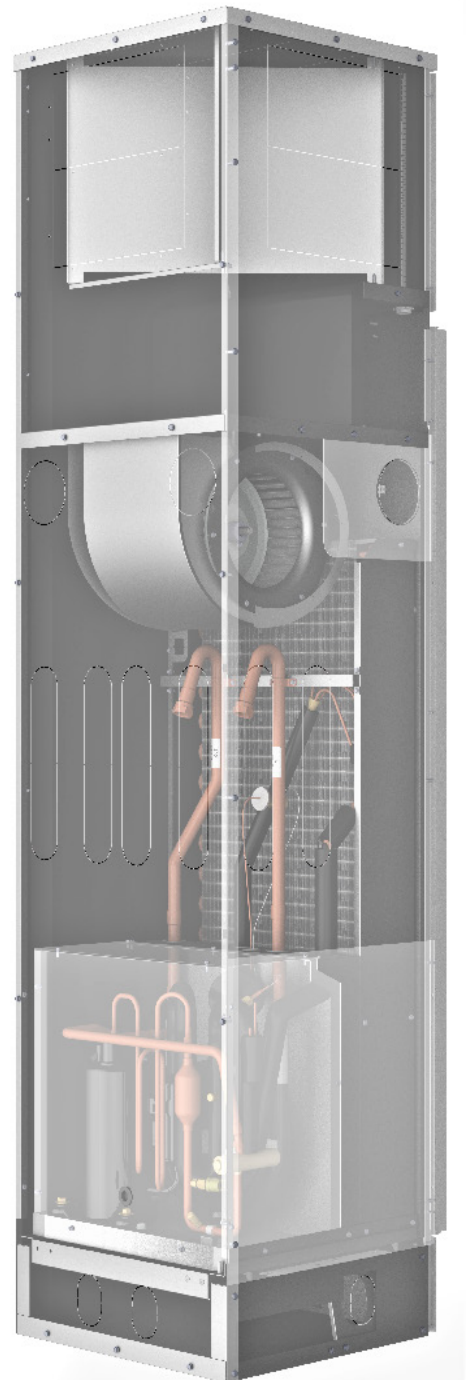

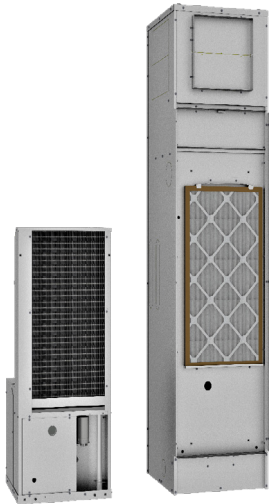

**HRCX CHASSIS AND HR CABINET**

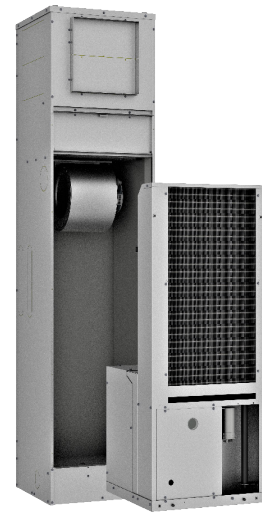

**SLIDE IN HRCX CHASSIS TO HR**

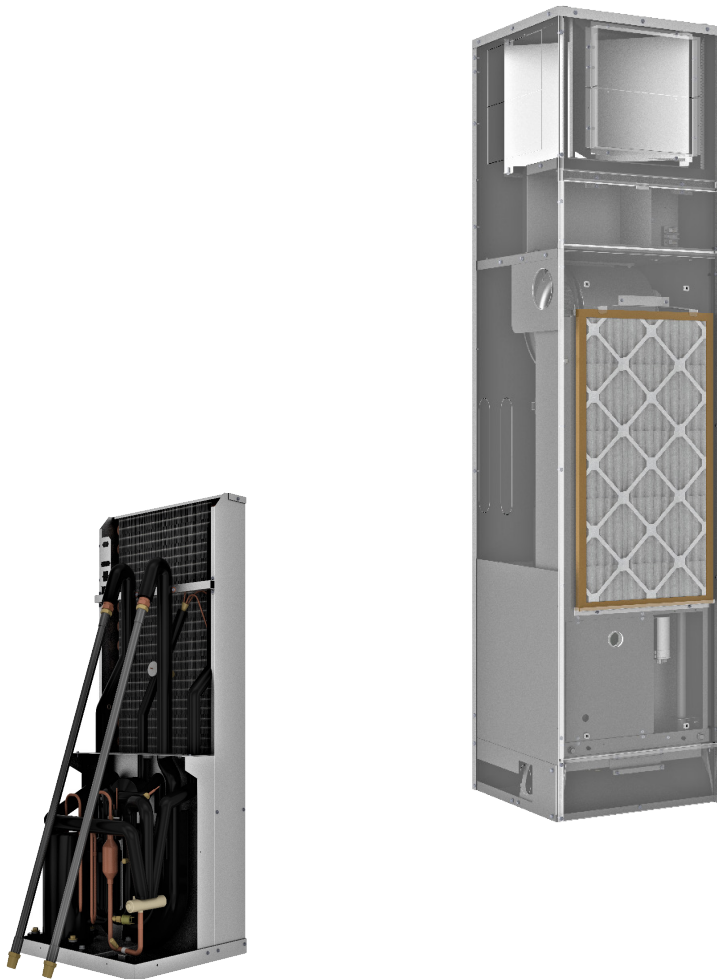

**HRCX CHASSIS FULLY INSULATED  
PIPING FOR GROUND LOOP  
APPLICATIONS**



**HRCX CHASSIS UN-INSULATED  
PIPING FOR STANDARD WATER  
CONDITIONS**

# HRCX-FHR Series

## COMMERCIAL WATER SOURCE HEAT PUMP

### GUIDE SPECIFICATIONS

**General** - Equipment shall be completely assembled, piped, internally wired, fully charged with R-410A refrigerant and test operated at the factory. Filters, thermostat field inter face terminal strip, and all safety controls are furnished and factory installed. The 3-ton and below equipment shall contain ETL, CETL and ISO –ARI 13256-1 listings and labels prior to leaving the factory.

**Unit Cabinet** - The structural integrity of the cabinets shall remain unaffected by the removal of any or all access panels. Fabricated from a minimum of 18 gauge galvanized steel. Access for inspection and cleaning of the unit drain pan, coils and fan section shall be provided. The unit shall be installed for proper access.

**Cabinet Stand (OPTION)** - Heavy gauge galvanized sheet metal stand field-attached to bottom of cabinet, Contact factory.

**Cabinet Insulation** - The insulation meets the erosion requirements of UL 181. The cabinets are insulated with 3/4" FSK, 1.8 scf density, Temperature Limit 350° (177°C) (unfaced), meets requirements of ASTM C1071, type 1 rolls. Fire hazard: 25/50 Flame/Smoke Developed Ratings (per ASTM E84, UL723, and CAN/ULC S102-M88).

**Cabinet Construction for Surface Mounted Thermostat** - Cabinet has pre-wired 2 x 4 x 1 7/8 deep electric box mounted for horizontal thermostat. Contractor must turn prior to dry walling if field-supplied vertical thermostat is used. Wire harness ends with 9-Pin Molex quick connector for easy connection to factory provided thermostats or can be cut off. See Cabinet decoder.

**Discharge arrangements** - Field selectable discharge air arrangements with knockout on all 4 sides of unit cabinet.

**Filter Section** - Includes 1" disposable type fiberglass filters and premium extruded rubber gasket on panel.

**2" Filter (Option)** - 2" filter improves air filtration and reduces maintenance.

**Accessory Filters** (Not available for every application - check blower table for ESP)

- 1" thick, MERV 8, and MERV 11
- 2" thick, MERV 8, MERV 11, MERV 13

**Drain Pans** - The condensate pan is constructed of corrosion resistant material. The bottom of the drain pan is sloped on two planes which pitches the condensate to the drain connection. Each drain pan includes an electronic condensate overflow switch.

**Sound Attenuation (Option)** - Provide a heavy duty, insulated compressor cover that reduces unwanted compressor noise (DUE TO ACCESS), this option must be field installed on the unit before unit is installed).

**Blower Assemblies** - Wheels are double width, double inlet (DWDI), forward curved, centrifugal type. They are statically and dynamically balanced for a smooth, quiet operation. The Class I housing is constructed of heavy gauge steel with die-formed inlet cones.

## GUIDE SPECIFICATIONS (CONT.)

**DCMotors (ECM)** - Three motor leads connect directly to the control board. Gray is a 50% speed used when only "fan" is selected. Violet and White are the ramp up speeds used when in normal heating or cooling modes. See wiring diagram for proper speed tap selection.

**Copper Coaxial Heat Exchanger** - Features a tube in tube coaxial water-to-refrigerant heat-exchanger and constructed of a convoluted copper (optional Cupro-Nickel) inner tube and steel outer tube with a designed refrigerant working pressure of 450 PSIG (3100 kPa) and designed water side working pressure of no less than 400 PSIG (2750 kPa)

**Compressor** - Units contain a high efficiency rotary, scroll compressor. External vibration isolation is provided by rubber mounting devices located underneath the mounting base of the compressor. Internal thermal overload protection is provided. Protection against excessive discharge pressure is provided by means of a high pressure switch. A loss of charge is provided by a low pressure safety switch.

**Reversing Valve** - A system reversing valve (4-way valve) is included with all heating/cooling units. This valve is piped to be energized in the cooling mode to allow the system to provide heat if valve failure were to occur. Once the valve is energized for cooling, it will remain energized until the control system is turned to the OFF position, or a heating cycle is initiated.

**Evaporative Coils** - R-410A Refrigerant with TXV metering device - 3/8" inch staggered tube type construction with seamless copper tubes, and deep corrugated aluminum fins with straight edges. Fins are manufactured with full depth collars, drawn in the fin stock to provide accurate control of fin spacing and completely cover the copper tubes to lengthen coil life. The tubes are mechanically expanded into the fins for a permanent primary to secondary surface bond, assuring maximum heat transfer efficiency. Coil includes moisture carryover diffuser. Internally finned, 3/8-inch copper tubes mechanically bonded to a configured aluminum plate fin shall be standard. Coils shall be leak tested at the factory to ensure the pressure integrity. The coil shall be leak tested to 450 psig and operating pressure tested to 650 psig. The tubes are to be completely evacuated of air and correctly charged with proper volume of refrigerant prior to shipment. The refrigerant coil distributor assembly shall be of orifice style with round copper distributor tubes. The tubes shall be sized consistently with the capacity of the coil.

**Electrical** - The unit control box shall contain all necessary devices to allow heating and cooling operation to occur from a remote wall thermostat. Unit to include a control module that controls the units operation and monitors the safety controls that protect the compressor, heat ex-changer, wiring and other components from damage caused by operating outside of design conditions.

- **24V Status LED** - Green light indicates 24V power to the control module.
- **50 VA Transformer** - Assists in accommodating accessory loads.
- **Anti-short Cycle Timer, Alarm Relay** - Activated if the unit locks out.
- **Condensate Overflow Lockout** - Consist of an electronic sensor mounted to the drain pan. When condensate pan liquid reaches an unacceptable level, the unit is automatically deactivated and placed in a lockout condition.
- **Random Restart Timer** - Unit provided with a random restart timer to ensure a random delay in energizing each different HRC unit to minimize peak electrical demand during start-up from different operating modes or after building power outages.
- **Nuisance Trip Protection** - Unit shall attempt to start up to three times with a fault signal. If the fault continues, the unit locks out.

## GUIDE SPECIFICATIONS (CONT.)

- **Digital Control Module (DCM)** - Controls unit operation and monitors all safety controls. (Patent Pending)
- **Accessory Relays (2)** - Relays can be selected to cycle with either the fan or compressor. Relay "1" can be configured for use with slow opening water valves (60 second pre-compressor initialization) and relay "2" can be configured for a 30 second post fan delay.
- **Test Mode** - Test pins can be momentarily jumped to enter into a 10 minute test mode period in which all time delays are sped up to 15 times. While in the test mode the LED Display will display a code representing the last fault in memory.
- **High Pressure Switch** – Located on the discharge line of the refrigeration circuit.
- **Low Pressure Switch** – Located on the suction line of the refrigeration circuit.
- **Low Temperature Cutout Sensor** – Located on the heat exchanger to prevent unit operation below low temperature setting.
- **Condensate Overflow Switch** – Sensor located in the drain pan to prevent overflow.
- **Over / Under Voltage Shutdown** - Should an Over / Under Voltage condition be detected, the module will initiate a shutdown. Over / Under Voltage Shutdown is a in that if the voltage comes back with range of 18.5VAC to 31VAC, then normal operation will be restored.
- **Vacated Premises Control (VPC) (OPTION)** - The vacated premises operation is designed for extended periods of non-occupancy when the occupant desires the heat pump to operate in the cooling mode for a predetermined cycle time to help control indoor air conditions.
  - **HOME selection** - if the switch is in the HOME position the heat pump will operate in its normal mode.
  - **AWAY selection** - if the switch is in the AWAY position and the thermostat is set to the "COOL" mode the heat pump will operate in accordance to the thermostat setting.

Additionally the heat pump will cycle on in the cooling mode for 15 minute run times either 4 or 8 times per day depending on Dip 1.7 selection. (See Installation Instructions). This option also includes an automatic reset feature. If a fault occurs, the system will shut down, but then automatically reset every 24 hours. If the same fault exists each day, the unit will lockout on the fourth day and have to be manually reset.

### Field selectable settings:

- **5 Second Compressor Delay** - Blower starts before the compressor, attenuates compressor start up sound.
  - **45 Second Blower-off Delay** - Increases cooling efficiency.
  - **Continuous Dehumidification Mode** - Selects continuous low speed fan operation for increased humidity removal.
- Thermostat Wiring Harness (WHIP) (OPTION)** - Low voltage wire harness 15, 25, or 35 foot ending with 9-Pin Molex quick connector. Exits cabinet on top, left front corner. Thermostat cable is rated CL-2. See Cabinet decoder. Can be encased in BX conduit as special, contact factory.



## GUIDE SPECIFICATIONS (CONT.)

**Water Loop Valve Package Components – OPTIONAL Valve packages** are available and can be configured with the following components to meet specific specifications:

- **FH - Flexible Hoses (STANDARD)** enable the Supply and Return water connections between the Unit and the water Loop Risers. The two stainless steel FH are made of a stainless-steel outer braid with an inner core of tube made of a nontoxic synthetic polymer material. Fire rated materials per ASTM E84-00 (NFPA 255, ANSI/UL 723 & UBC 8-1). The FH terminations are swivel MPT (Male Pipe Thread) fitting at one end and at the opposite end with a NPSH thread connector (internal thread) sealed with a fiber or EPDM washer, shipped inside the connection. Swivel connection provides union between chassis and risers. The FH have a max working pressure of 400 PSI, temperature operating range of 15°F to 180°F however operation below 32°F requires antifreeze.

- **AWBV - Automatic Water Balancing Valve (OPTIONAL)** regulates the amount of water into each unit to enable a proper Water System balance. The AWBV is provided from the factory at specific selectable flow rates and automatically controls the water flow to within 10% of the rated value over a 40 to 1 differential pressure, and operating range (2 to 80 PSID). The AWBV has an operating pressure rate of XX psi with a temperature range of 32 to 225°F, and a pressure differential range of 2 to 80 PSID. The AWBV is manufacture with precision sculptured brass and a polyphenylsulfone orifice with an elastomeric diaphragm. The valve body shall be construct from hot forged brass UNS C37700 per ASTM B-283 latest revision.

- **ST - Strainer (OPTIONAL)** – The ST valve body is constructed from dezincification resistant brass with a 600 PSI and a max working temperature of 325°F. The ST filter screen is made of a 20-mesh screen constructed of 304 stainless steel and removable via a cap with an FKM sealing O-Ring. The ST cap has a ¼" or ½" FNPT Port to which a blowdown ball valve is attach including a hose bib threaded connection and cap.

- **IBV - Isolation Valves (OPTIONAL)** - Isolation ball valves mounted between the unit and the supply and return lines of the loop to isolate the water flow to the unit in a maintenance or service situation. The IBV are rated to 600 psi non-shock cold working pressure. Full port, two-piece body with blowout-proof stem and PTFE Seats. ASME B16.33: 125 psig (maximum) and operating temperature of -4°F to 194°F.

- **MCV - Motorized Control Valves (OPTIONAL)** – The MCV actuator is easily removed, ON/OFF type, 2-way, normally close with a spring close actuation and actuates with a 24VAC control signal. The MCV valve comes in two options. MCV Option 1 valve body can operate at a maximum operating pressure of 360 psi, a maximum pressure differential of 75 PSI, operating with fluid temperatures between 36°F to 212°F and a max glycol percentage allowable of 60%. MCV Option 2 valve body can operate at a maximum operating pressure of 300 psi, a maximum pressure differential of 125 PSI, operating with fluid temperatures between 20°F to 220°F and a max glycol percentage allowable of 50%.

# HRCX Series

## PHYSICAL DATA

MODEL - SIZE	HRCX	9	12	18	24	30	36
<b>Compressor (1 Each)</b>	1 Each	Rotary			Scroll		
<b>Refrigerant Type</b>		<b>R410A</b>					
<b>Factory</b>	(Lb.) [oz.]	1.7 [27]	2.7 [43]	2.7 [43]	3.7 [59]	3.7 [59]	3.6 [57]
<b>Motor</b>	Type	ECM					
	Speeds	Multiple					
	HP [kw]	1/4 [.18]	1/4 [.18]	1/3 [.24]	1/3 [.24]	1/2 [.37]	1/2 [.37]
<b>Blower Wheel (Dia. x W)</b>	(Dia x W) in. [cm]	6.75 x 7 [17.15 x 17.78]		9 x 7 [22.86 x 17.78]			10 x 8 [25.4 x 20.32]
<b>COAX Volume</b>	(US Gallons)	0.116	0.116	0.144	0.544	0.544	0.544
<b>Condenser Water Connections</b>	(in)	1/2	1/2	3/4	1	1	1
<b>Condensate Connection</b>	I.D.(in) / O.D.(in)	7/8 / 1-1/8					
<b>Air Coil Dimension</b>	(W x H) in. [cm]	14 x 28 [ 5.5 x 11.0]			18 x 30 [7.1 x 11.8]		
<b>Standard TA Filter 1"</b>	(W x H) in. [cm]	16 x 30 [6.3 x 11.8]			20 x 32 [7.9 x 12.6]		
<b>Operating Weight</b>		Weight					
<b>Chassis</b>	Lb. [kg]	125 [57]	128 [58]	131 [59]	182 [83]	185 [84]	188 [85]
<b>80" Cabinet</b>		128 [58]			173 [78]		175 [79]
<b>88" Cabinet</b>		143 [65]			188 [85]		190 [86]

# HRCX Series

## ELECTRICAL DATA

ECM - ELECTRICAL DATA 208/230V-1-60							
MODEL NUMBER	VOLTAGE	COMPRESSOR		BLOWER		MIN. CIRCUIT AMPACITY	MAX. CIRCUIT PROTECTION
		RLA	LRA	FLA	HP		
HRCX09	208/230V-1-60	3.7	22	2.3	1/4	7	15
HRCX12	208/230V-1-60	4.7	25	2.3	1/4	9	15
HRCX18	208/230V-1-60	7.0	38	2.8	1/3	12	15
HRCX24	208/230V-1-60	10.9	62.9	2.8	1/3	17	25
HRCX30	208/230V-1-60	12.8	67.8	4.1	1/2	21	30
HRCX36	208/230V-1-60	15.4	82.6	4.1	1/2	24	35

ECM - ELECTRICAL DATA 265V-1-60							
MODEL NUMBER	VOLTAGE	COMPRESSOR		BLOWER		MIN. CIRCUIT AMPACITY	MAX. CIRCUIT PROTECTION
		RLA	LRA	FLA	HP		
HRCX09	265V-1-60	3.5	22	2.3	1/4	7	15
HRCX12	265V-1-60	4.2	22	2.3	1/4	8	15
HRCX18	265V-1-60	6.0	30	2.6	1/3	11	15
HRCX24	265V-1-60	9.0	54	2.6	1/3	14	20
HRCX30	265V-1-60	11.2	60	3.6	1/2	18	25
HRCX36	265V-1-60	12.2	72	3.6	1/2	19	30

# HRCX Series

## CAPACITY DATA

PERFORMANCE DATA - CERTIFIED AT AHRI/ISO 13256-1 CONDITIONS														
MODEL NUMBER	NOM. CFM (ECM)	GPM	WATER LOOP (EWT)				Ground Water (EWT)				Ground Water (EWT)			
			86 deg. F		68 deg. F		59 deg. F		50 deg. F		77 deg. F		32 deg. F	
			COOLING	EER	HEATING	COP	COOLING	EER	HEATING	COP	COOLING	EER	HEATING	COP
<b>HRCX09</b>	350	2.3	9,600	16.0	10,500	5.0	11,500	26.5	8,800	4.5	10,000	19.0	6,800	3.6
<b>HRCX12</b>	400	2.6	11,500	15.0	12,800	4.6	13,000	25.0	10,500	4.1	11,800	18.0	8,000	3.6
<b>HRCX18</b>	600	4.5	18,000	14.5	20,000	4.8	20,000	22.5	16,000	4.1	18,000	17.1	13,000	3.6
<b>HRCX24</b>	800	6.0	24,000	16.5	28,000	5.0	26,000	26.5	22,000	4.4	24,000	19.0	17,000	3.6
<b>HRCX30</b>	900	7.5	27,000	16.0	31,000	4.6	30,000	23.5	25,000	4.1	28,000	18.0	20,000	3.6
<b>HRCX36</b>	1125	9.0	34,000	14.5	38,000	4.7	35,500	21.6	31,500	4.1	34,100	17.1	25,000	3.6

### AHRI/ISO 13256-1 Conditions DATA AT 208V-230V/1/60

Cooling Entering Air temperature = 80.6°F WB / 66.2°F DB  
 Cooling Entering Fluid Temperature = 86°F

Heating: Entering air = 68°F DB° / 59° F WB  
 Heating Entering Air Temperature = 68°F

# HRCX Series

## BLOWER PERFORMANCE

ECM BLOWER DATA							BLOWER SETTINGS			
MODEL NUMBER	FAN SPEED	CFM vs EXTERNAL STATIC PRESSURE					COOLING			HEATING
		0.1	0.2	0.3	0.4	0.5	DEHUM <sup>1</sup>		NORMAL	
							0 - 10	10+		
HRCX09*	T3	430	410	380	360	340		X	X	X
	T2	360	330	300	280	250	X			
	T1	290	260	230						
HRCX12*	T3	490	460	440	420	410		X	X	X
	T2	390	360	340	310	290	X			
	T1	310	280	250	230					
HRCX18*	T3	770	740	700	660	610		X	X	X
	T2	650	620	590	560	530	X			
	T1	550	520	490	450	410				
HRCX24*	T3	940	910	870	840	800		X	X	X
	T2	840	810	770	740	700	X			
	T1	720	690	650	610	560				
HRCX30*	T3	1260	1210	1140	1060	970		X	X	X
	T2	1080	1050	1020	980	940	X			
	T1	990	960	930	900	870				
HRCX36*	T3	1300	1230	1150	1080	990		X	X	X
	T2	1260	1210	1140	1060	970	X			
	T1	1080	1050	1020	980	940				
CFM rated at 208V for 208-230V units										

# HRCX Series

## DIMENSIONAL DATA

Unit Size: 09, 12 and 18

### 80" TALL CABINET

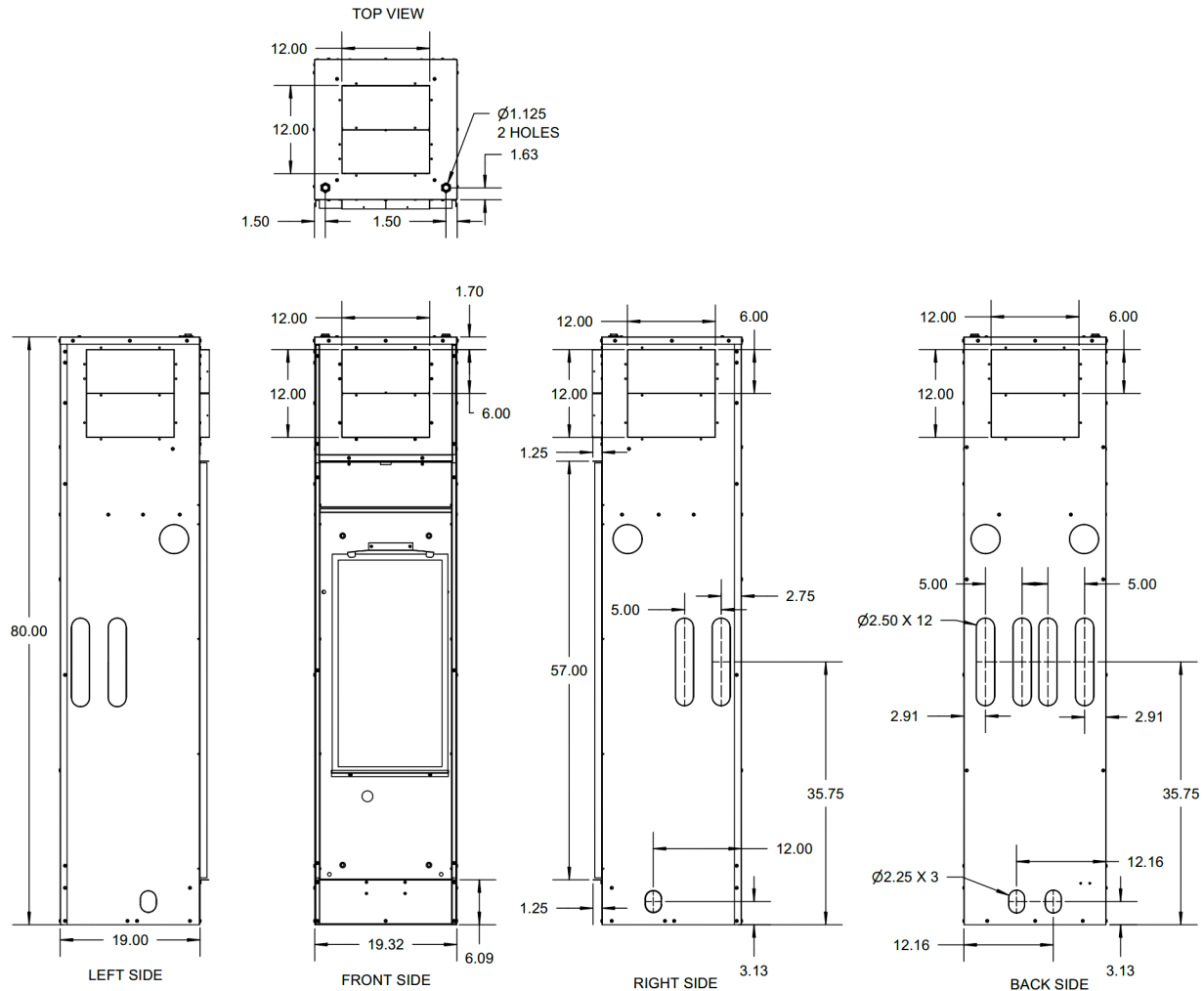

**HT Vertical High Rise Heat Pump Cabinet**

**NOTES:**

1. All dimensions are in inches.
2. The return air/control box side is defined as front of cabinet. Supply air K.O's and riser K.O's are on all panels. Supply air grilles can be on any side except riser side.
3. Units with 24v surface mount T/stat option have 2x4 box factory installed in horizontal position. Contractor must turn box before dry walling if customer is using vertical thermostat type.
4. Cabinet shown is Style 3, risers back right.
5. Supply air K.O's have to be field removed.
6. Supply air angles are shipped loose. Break off for 6" or 8". Position inside and attach with screws.
7. Service clearances: Front requires 24" from finished wall plus 4" added to cabinet width.

# DIMENSIONAL DATA

Unit Size: 24, 30 and 36

## 80" TALL CABINET

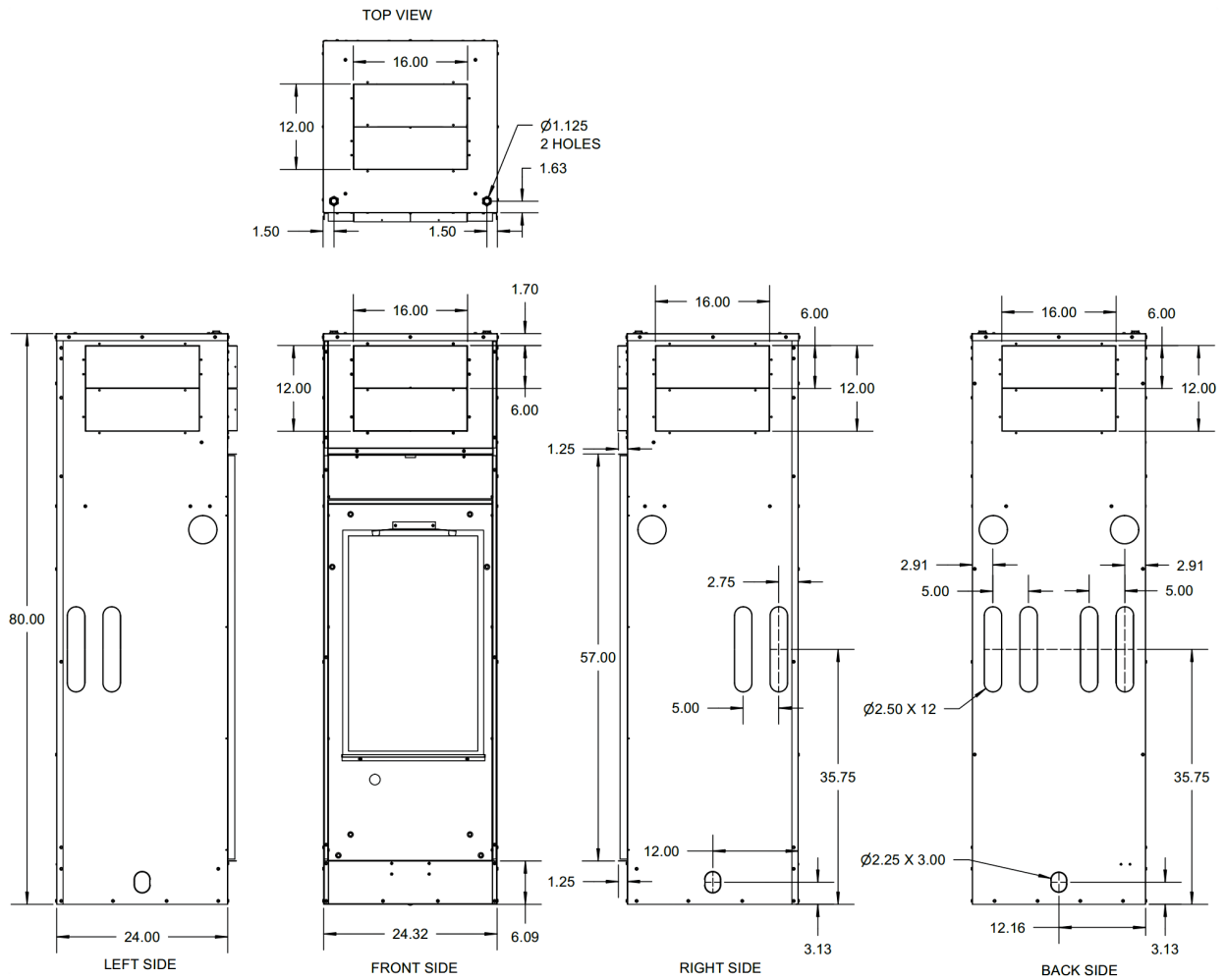

**HT Vertical High Rise Heat Pump Cabinet**

**NOTES:**

1. All dimensions are in inches.
2. The return air/control box side is defined as front of cabinet. Supply air K.O's and riser K.O's are on all panels. Supply air grilles can be on any side except riser side.
3. Units with 24v surface mount T/stat option have 2x4 box factory installed in horizontal position. Contractor must turn box before dry walling if customer is using vertical thermostat type.
4. Cabinet shown is Style 3, risers back right.
5. Supply air K.O's have to be field removed.
6. Supply air angles are shipped loose. Break off for 6" or 8". Position inside and attach with screws.
7. Service clearances: Front requires 24" from finished wall plus 4" added to cabinet width.

# HRCX Series

## DIMENSIONAL DATA

Unit Size: 09, 12 and 18

### 88" TALL CABINET

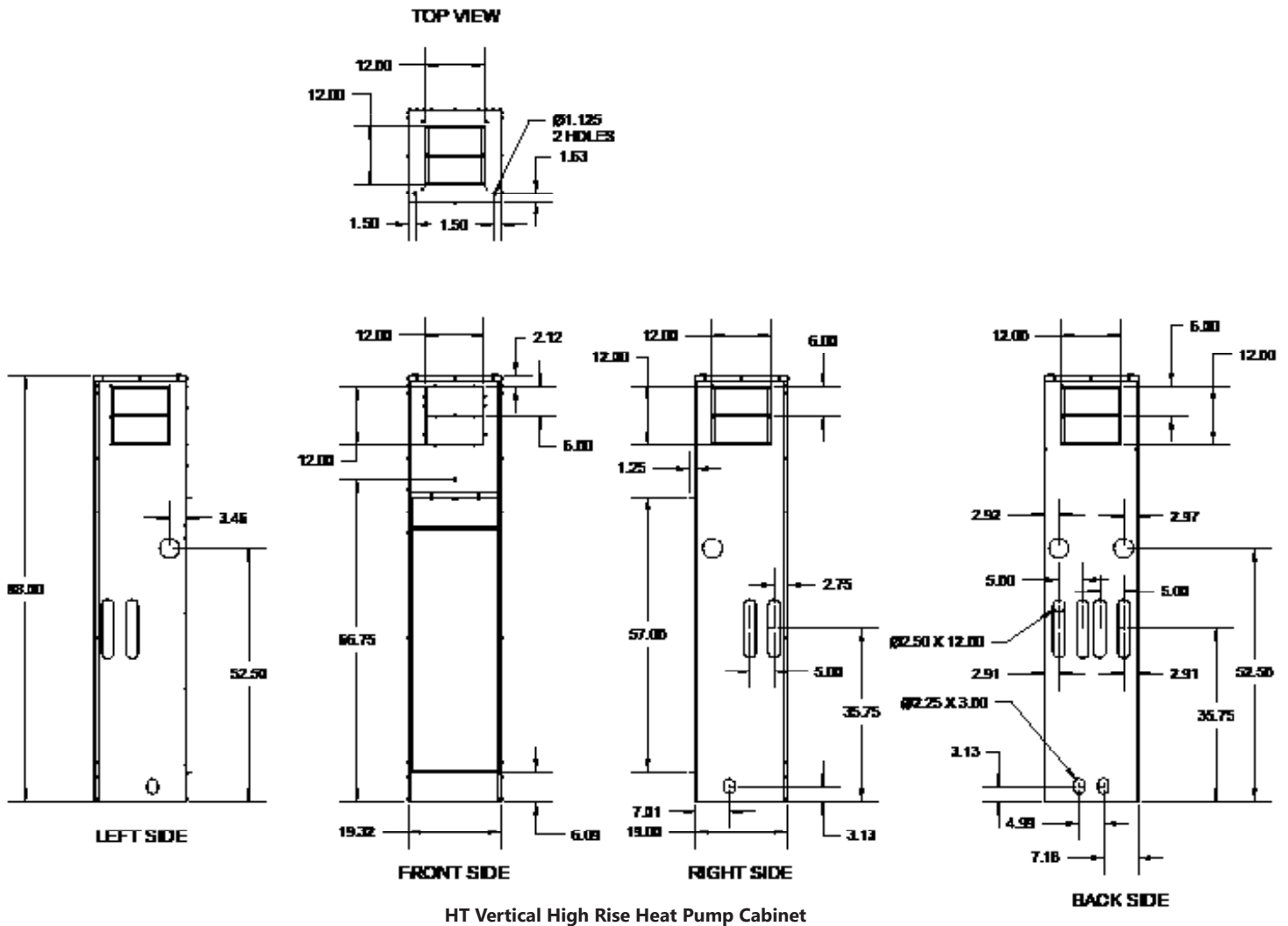

#### NOTES:

1. All dimensions are in inches.
2. The return air/control box side is defined as front of cabinet. Supply air K.O.'s and riser K.O.'s are on all panels. Supply air grilles can be on any side except riser side.
3. Units with 24v surface mount T/stat option have 2x4 box factory installed in horizontal position. Contractor must turn box before dry walling if customer is using vertical thermostat type.
4. Cabinet shown is Style 3, risers back right.
5. Supply air K.O.'s have to be field removed.
6. Supply air angles are shipped loose. Break off for 6" or 8". Position inside and attach with screws.
7. Service clearances: Front requires 24" from finished wall plus 4" added to cabinet width.



# DIMENSIONAL DATA

Unit Size: 24, 30 and 36

## 88" TALL CABINET

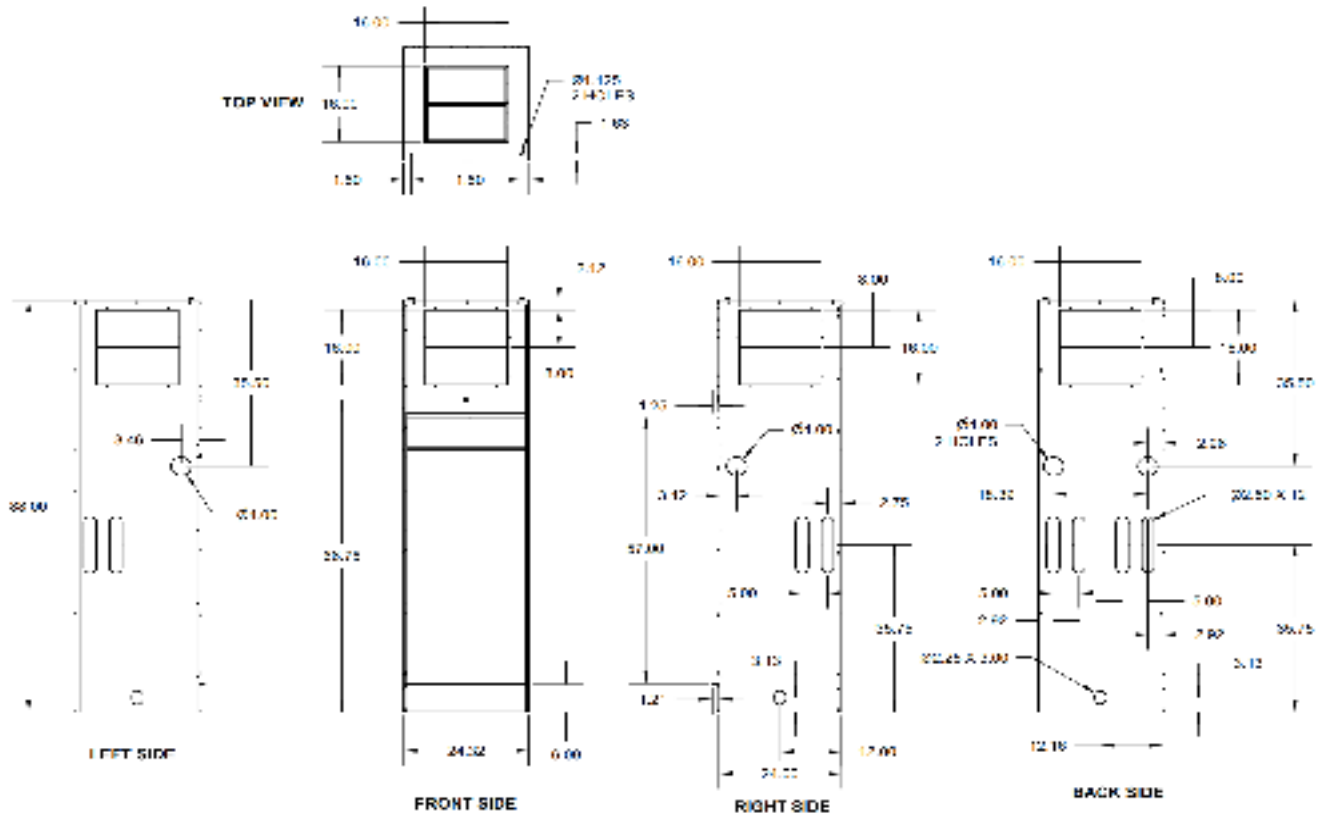

**HT Vertical High Rise Heat Pump Cabinet**

**NOTES:**

1. All dimensions are in inches.
2. The return air/control box side is defined as front of cabinet. Supply air K.O's and riser K.O's are on all panels. Supply air grilles can be on any side except riser side.
3. Units with 24v surface mount T/stat option have 2x4 box factory installed in horizontal position. Contractor must turn box before dry walling if customer is using vertical thermostat type.
4. Cabinet shown is Style 3, risers back right.
5. Supply air K.O's have to be field removed.
6. Supply air angles are shipped loose. Break off for 6" or 8". Position inside and attach with screws.
7. Service clearances: Front requires 24" from finished wall plus 4" added to cabinet width.

# PRIMARY/SECONDARY CABINET INSTALLATION

TOP VIEW

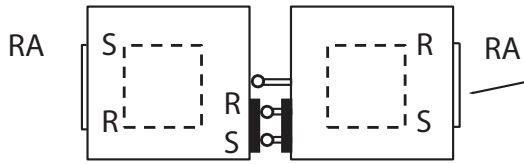

Field connect hoses in both cabinets supply to supply and return to return (Cabinet supply is closest to corner, chassis supply is on left facing air coil)

SIDE VIEW

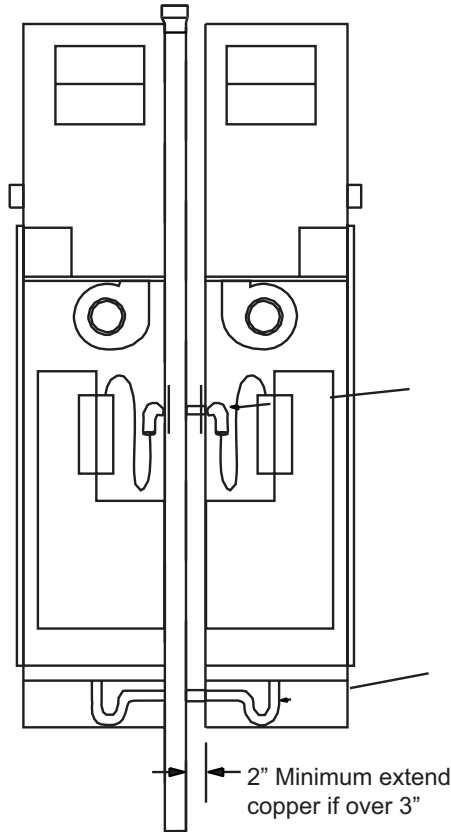

Field braze valve package (shut off with tubing)

Field install P-Trap and Clamp both ends

2" Minimum extend copper if over 3"

*When cabinets are pushed up to risers allow sufficient clearance. Shutoffs should be inside cabinet.*

TOP VIEW

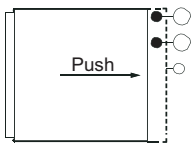

**Step 1**

Risers Opposite Return Air Opening

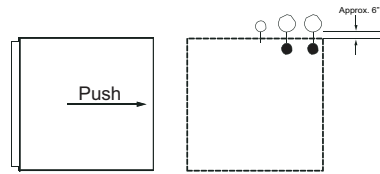

**Step 1**

Risers Adjacent to Return Air Opening

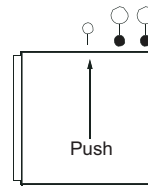

**Step 2**

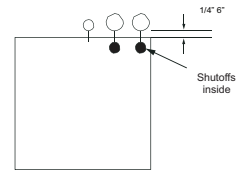

**Final Cabinet Position**

# VALVE PACKAGES AND ACCESSORIES

## CABINET CONFIGURATIONS

Air Flow Configuration

**NONE**

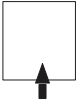

**Right Side**

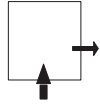

**Left Side**

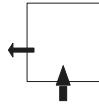

**Left & Right Sides**

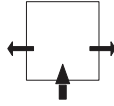

**Back**

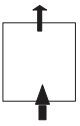

**Back & Right**

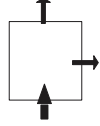

**Back & Left**

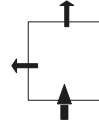

**Front**



**Front & Right**

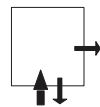

**Front & Left**

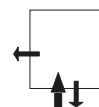

**Front, Left & Right**

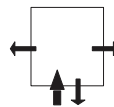

**Top**

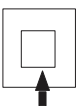

**Top & Right**

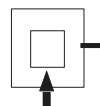

**Top & Left**

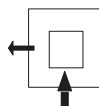

**Top, Left & Right**

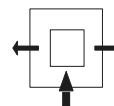

**Top & Back**

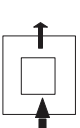

**Top, Back & Right**

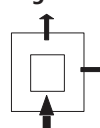

**Top, Back & Left**

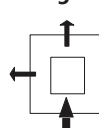

**Top & Front**

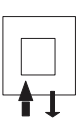

**Top, Front & Right**

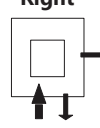

**Top, Front & Left**

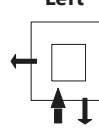

**Front & Back**



**Front, Back & Right**

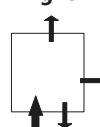

**Front, Back & Left**

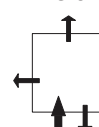

**Front, Back & Top**

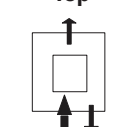

↑ = RETURN AIR (AIR ENTERING CABINET)

↑ = SUPPLY AIR (AIR LEAVING CABINET)

**NOTES:**

1. Front is return air side and control box location.
2. Risers can be on any side without return or supply air openings.
3. All sides and top have KO's.

# HRCX-FHR Series

## COMMERCIAL WATER SOURCE HEAT PUMP

### ACCESS RETURN PANEL

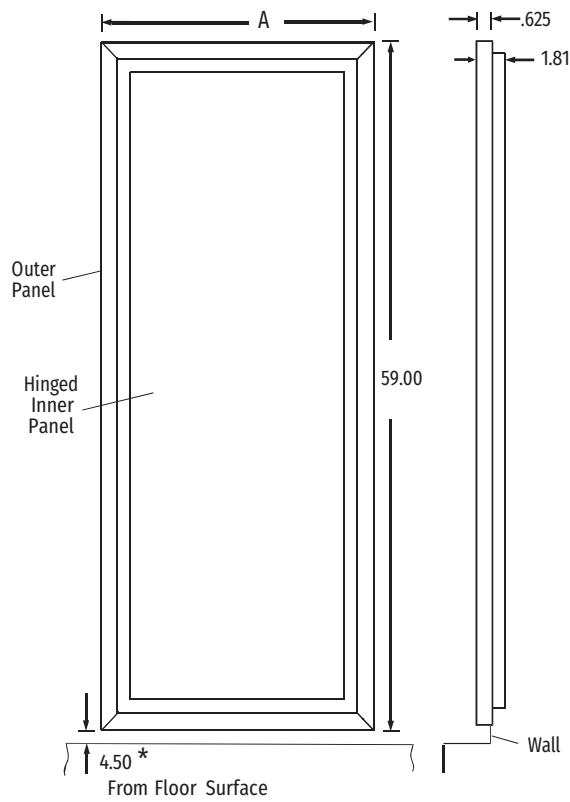
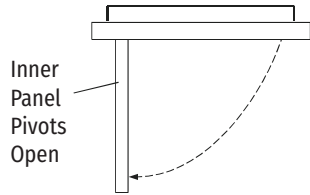

Front View  
Standard Panel

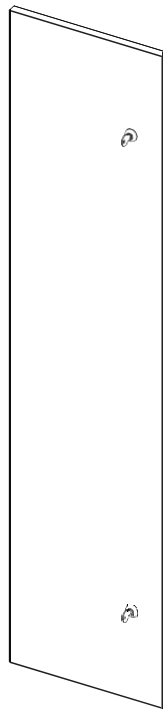

Optional  
Inner  
solid panel

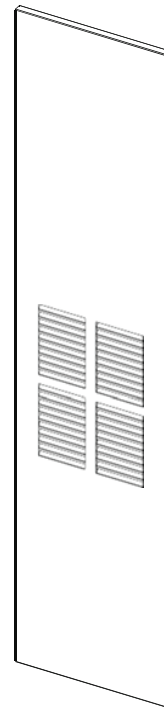

Optional  
Inner panel  
with Grille  
(Stamped Louvers)

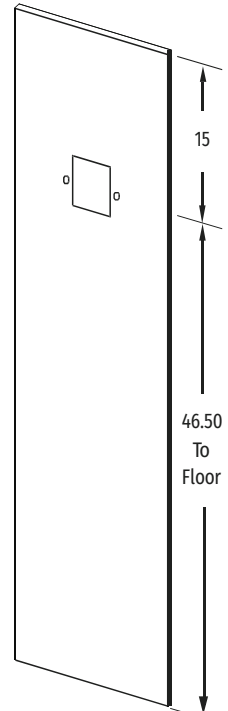

Optional  
Inner Panel with  
holes to mount  
ADA Thermostat

Unit	A	PANEL PART NUMBERS	
09-18	21.50	09-18 SIZE	9PWHR01
24-36	25.50	24-36 SIZE	9PWHR02

NOTES:

1. Dimensions are in inches.
2. Panel powder coated ceiling white.
3. Inner panel pivots open 90°, for filter replacement without removing panel.
4. Shipped as left-hand pivot.

# HRCX-FHR Series

## COMMERCIAL WATER SOURCE HEAT PUMP

### CABINET PLATFORMS SPECIFICATIONS

- 12" tall
- 16 Gauge galvanized steel
- Attached to cabinet with 4 screws
- Field installed

Unit	A	B	C
09-18	18.86	18.25	12
24-36	23.86	23.25	

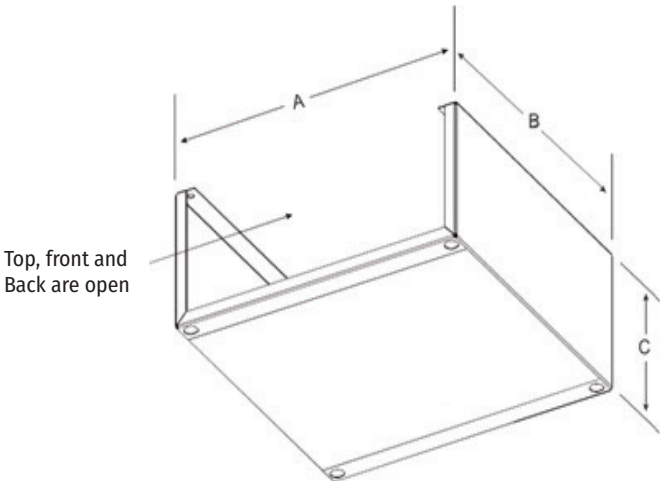

## DISCHARGE AIR OPENINGS

<b>DISCHARGE AIR OPENINGS (Any Combination, Top and Sides, Grilles or Ductwork)</b>				
Unit Size	1 Opening	2 Openings	3 Openings	4 or more Openings
<b>9FHR,12FHR</b>	12" x 12"	12" x 6"		
<b>18FHR</b>		12" x 12"	12" x 6"	
<b>24FHR</b>		16" x *	16" x **	
<b>30FHR</b>		16" x *	16" x **	
<b>36FHR</b>		16" x *	16" x **	

\* - 88" CABINET = 16"  
\*\* - 88" CABINET = 8"

### Standard cabinet openings and grille sizes. (W x H)

#### 88" cabinet models 09-18

front, back, or sides 12 x 12 or 12 x 6 and top 12 x 12.

#### 88" cabinet models 24-36

front, back, or sides 16 x 16 or 16 x 8 and top 16 x 16.

#### NOTES:

1. When selecting supply air openings/grilles consider CFM, velocity (throw), added static pressure and sound.
2. If custom grille sizes are used - area should be greater or equal to above.
3. If using more than recommended number of opening, total CFM may be reduced or be unstable (PSC or ECM Motor).

### Important!

Top air discharge units will require turning vanes and/or a volume damper for proper air flow and balancing, to minimize turbulence. These components must be field furnished and installed in accordance with SMACNA guidelines.

## GRILLES

Grilles are shipped loose for field installation after drywall has been finished.

Grilles are brushed aluminum or painted (White).

Overall dimensions - add 1.25 to nominal dimensions.

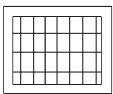

1.88

**Single Deflection**- Adjustable vertical blades for controlling horizontal path of discharge air (Left/Right).

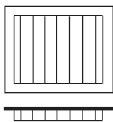

**Double Deflection**- Adjustable vertical and horizontal blades for controlling horizontal and vertical path of discharge air. (Left/Right and Up/Down) Recommended for all standard applications.

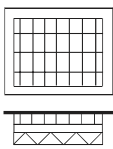

3.25

#### Double Deflection with Opposed Blade Damper-

Addition of opposed blade damper to grille allows control of air volume (CFM) and path of discharge air. Recommended for applications requiring unequal air flow or side discharge grille(s) with additional top discharge air opening.

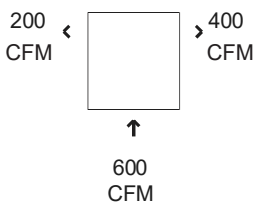

**Unequal Air Flow** - Air discharges requiring different air volumes (CFM). Use double deflection with opposed blade damper grilles.

Nominal Grille Size	Double Deflection Free Area (Sq. Ft)		
	Deflection 0°	Deflection 22 1/2°	Deflection 45°
<b>12 x 6</b>	0.30	0.28	0.22
<b>12 x 12</b>	0.65	0.59	0.48
<b>16 x 8</b>	0.61	0.55	0.44
<b>16 x 12</b>	0.93	0.85	0.68
<b>16 x 16</b>	1.25	1.12	0.90

# HRCX-FHR Series

## COMMERCIAL WATER SOURCE HEAT PUMP

### GUIDE SPECIFICATIONS

#### General

Equipment shall be completely assembled, piped, internally wired, fully charged with R-410A refrigerant and test operated at the factory. Filters, thermostat field inter face terminal strip, and all safety controls are furnished and factory installed. The 3-ton and below equipment shall contain ETL, CETL and ISO-ARI 13256-1 listings and labels prior to leaving the factory.

#### Air to Air Refrigerant Coil

Internally finned, 3/8-inch copper tubes mechanically bonded to a configured aluminum plate fin shall be standard. Coils shall be leak tested at the factory to ensure the pressure integrity. The coil shall be leak tested to 450 psig and operating pressure tested to 650 psig. The tubes are to be completely evacuated of air and correctly charged with proper volume of refrigerant prior to shipment. The refrigerant coil distributor assembly shall be of orifice style with round copper distributor tubes. The tubes shall be sized consistently with the capacity of the coil. Suction header shall be fabricated from rounded copper pipe. A thermostatic expansion valve shall be factory selected and installed for a wide range of control.

#### Reversing Valve

A system reversing valve (4-way valve) is included with all heating/cooling units. This valve is piped to be energized in the cooling mode to allow the system to provide heat if valve failure were to occur. Once the valve is energized for cooling, it will remain energized until the control system is turned to the OFF position, or a heating cycle is initiated. Units with the cooling only option will not receive a reversing valve.

#### Automatic Flow Devices (Option)

The automatic flow kit shall contain a Hays Mesurflo® automatic flow control valve, two ball valves, two flexible stainless steel hoses, a high flow Y-strainer, and may include a strainer blow-down and various other accessories. The automatic flow control valve shall be factory set to a rated flow, and shall automatically control the flow to within 10% of the rated value over a 40 to 1 differential pressure, operating range (2 to 80 PSID). Operational temperature shall be rated from fluid freezing, to 225°F. The valve body shall be constructed from hot forged brass UNS C37700 per ASTM B-283 latest revision. For more information pertaining to the automatic balancing hose kits. See literature documentation.

#### Ball Valves (Option)

Ball valves shall be field installed between the unit and the supply and return lines of the loop to stop water flow to the unit in a maintenance or service situation.

#### Cabinet

The structural integrity of the cabinets shall remain unaffected by the removal of any or all access panels. All panels shall be insulated with 3/4" Foil Face fiberglass. The insulation meets the erosion requirements of UL 181. It has a flame spread of less than 25 and a smoke developed classification of less than 50 per ASTM E-84 and UL 723. Access for inspection and cleaning of the unit drain pan, coils and fan section shall be provided. The unit shall be installed for proper access.

#### Compressors

Unit contains a high efficiency rotary or scroll compressor. External vibration isolation is provided by rubber mounting devices located underneath the mounting base of the compressor. Provide internal thermal overload protection against excessive discharge pressure is provided by means of a high pressure switch. A loss of charge is provided by a low pressure safety switch.

#### Basic Controls

Units shall include the following controls and functions. Service test mode with diagnostic LED shall allow service personnel to check the operation of the FHR and control system efficiently. Upon entering Test mode, time delays speed up, and the Status LED displays a code to indicate the last fault experienced. This mode shall provide easy fault diagnosis; based on the fault code that the status LED displays.

#### 24V Status LED

Shall be Green light indicators proving 24V power to the control module.

#### VPC (Vacated Premises Control Option)

Shall allow the unit to operate for either 1 or 2 hours per day (total) during extended periods of no occupancy. (Requires optional kit).

#### Nuisance Trip Protection

Unit shall attempt to start up to three times with a fault signal. If the fault continues, the unit locks out.

**Condensate Overflow** lock out shall consist of an electronic sensor mounted to the drain pan. When condensate pan liquid reaches an unacceptable level, the unit is automatically deactivated and placed in a lockout condition.

# GUIDE SPECIFICATIONS (CONT.)

## **Provide High and Low Pressure Switches.**

**Provide condenser coil low temperature protection**, high/low voltage protection because of high or low voltage conditions.

**Provide a random re-start timer to ensure a random delay** in energizing each different HRC unit to minimize peak electrical demand during start-up from different operating modes or after building power outages. Provide the circuit board with conformal coating (both sides of board) for humidity and condensation protection.

**Provide Anti-short Cycle Timer, Alarm Relay** - Activated if the unit locks out. Provide Field selectable settings:

**5 Second Compressor Delay** - Blower starts before the compressor, attenuates compressor start up sound.

**45 Second Blower-off Delay** - Increases cooling efficiency.

**Continuous Dehumidification Mode** - Selects continuous low speed fan operation for increased humidity removal.

Provide Accessory Relays (2) - Relays can be selected to cycle with either the fan or compressor. Relay "1" can be configured for use with slow opening water valves (60 second pre-compressor initialization) and relay "2" can be configured for a 30 second post fan delay.

## **Drain Pans**

The condensate pan shall be constructed of corrosion resistant material. The bottom of the drain pan shall be sloped on two planes which pitches the condensate to the drain connection. The drain pan shall be flame rated per UL945V-B.

## **Electrical**

The unit control box shall contain all necessary devices to allow heating and cooling operation to occur from a remote wall thermostat. These devices shall be as follows:

- 24 VAC energy limiting class II [50 VA (minimum) transformer]
- 24 VAC blower motor relay
- 24 VAC compressor contactor for compressor control
- Thermostat connections shall be provided for ease of hook-up to a terminal strip located in the unit's control box.
- One inch filters shall be standard and factory installed. Hoses (option)
- Hoses shall consist of a stainless steel outer braid with an inner core of tube made of a nontoxic synthetic polymer material. The hoses shall be suitable for water temperatures ranging between 33°F and 211°F without the use of glycol.

**Sound Attenuation (Option)** Provide a heavy duty, insulated compressor cover that reduces unwanted compressor noise (DUE TO ACCESS), this option must be field installed on the unit before unit is installed).

**Motors** to be multi-speed, 230V, single phase, 60-Hz, permanent split capacitor (PSC) type, factory mounted to the blower assembly with rubber isolators.

## **Refrigerant Tubing**

The refrigerant tubing shall be copper. This system shall be free from contaminants and conditions such as drilling fragments, dirt and oil.

## **Refrigerant Circuits**

The refrigerant circuit shall contained a thermal expansion device (TXV). Service pressure ports shall be factory supplied on the high and low pressure sides for easy refrigerant pressure or temperature testing.

**Indoor Blower Wheels** are double width, double inlet (DWDI), forward curved, centrifugal type. They are statically and dynamically balanced for a smooth, quiet operation. The Class I housing is constructed of heavy gauge steel with die-formed inlet cones.

**Coaxial Heat Exchanger**, features a tube in tube coaxial water-to-refrigerant heat exchanger and constructed of a convoluted copper (optional cupro-nickel) inner tube and steel outer tube with a designed refrigerant working pressure of 450 PSIG (3100 kPa) and designed water side working pressure of no less than 400 PSIG (2750 kPa)

## **Control Module and Safety Devices**

Unit to include a control module that controls the units operation and monitors the safety controls that protect the compressor, heat ex-changer, wiring and other components from damage caused by operating outside of design conditions. Safety controls include the following:

- High pressure switch located in the refrigerant discharge line.
- Low pressure switch located in the refrigerant suction line.
- Water coil low temperature cutout sensor located on the heat exchanger to prevent unit operation below low temperature setting.
- Condensate overflow protection sensor located in the drain pan.
- The control module includes the following features:
  - **Anti-Short Cycle Timer** - 5 minute anti-short cycle protection for the compressor. NOTE: THE 5 MINUTE ANTI-SHORT CYCLE ALSO OCCURS AT POWER UP.
  - **Random Start** - The controller features a 5-80 second random start upon power up.
  - **Low Pressure Bypass Timer** - The low pressure switch input is bypassed for the initial 120 seconds of a compressor run cycle to prevent nuisance low pressure lockouts.
  - **Over / Under Voltage Shutdown** - Should an Over / Under Voltage condition be detected, the module will initiate a shutdown. Over / Under Voltage Shutdown is a in that if the voltage comes back with range of 18.5VAC to 31VAC, then normal operation will be restored.
  - **Alarm Relay** - The module has a set of contacts for remote fault indication. Contacts can be 24VAC output or converted to a dry contact.
  - **Test Mode** - Test pins can be momentarily jumped to enter into a 10 minute test mode period in which all time delays are sped up to 15 times. While in the test mode the LED Display will display a code representing the last fault in memory.



# PACKAGING AND SHIPPING OPTIONS

## Units Are Shipped FOB Factory

### Chassis can be shipped 2 ways.

1. Upright in carton 4 per pallet, see figure 1.
2. Upright inside cabinet (risers shipped separate or customer supplied) 4 per pallet, see figure 1.

### Cabinet without risers attached can ship upright 4 per pallet, see figure 1.

Cabinet with risers attached must be shipped horizontal and normally on dedicated open flatbed trailer either 3 or 6 per pallet, see figure 2 and 3. Cabinets are palletized to maximize shipping density then grouped by unit size, building, and floor where possible. Pallets are stretch wrapped and flatbed load is tarped for protection. Special shipping accommodations can be provided. Request added cost before quoting job, shipping cost could increase significantly and any additional charges will be billed. Some examples include, end fork pallets, reduced number of units per pallet, palletized specifically by riser, by floor, or over crating.

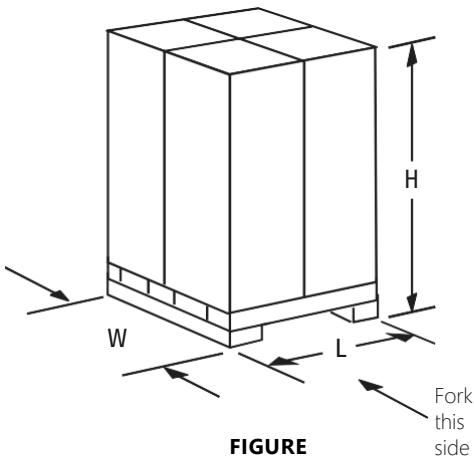

Description	Vertical Shipping			Approx. Quantity Per 53 foot Box Trailer	Approximate Weight per Pallet
	Per 4 pack on pallet				
	Length	Width	Height		
Chassis 09-18	40	40	50	120 single stacked	500 lbs
Chassis 24-36	50	48	52	96 single stacked	750 lbs
Chassis 09-18	40	40	100	240 single stacked	500 lbs
Chassis 24-36	50	48	104	192 single stacked	750 lbs
Secondary Cabinet 09-18	43	43	85/93	112 single stacked	450 lbs
Secondary Cabinet 24-36	53	53	85/93	72 single stacked	700 lbs
Cabinet with Chassis 09-18	43	43	85/93	112 single stacked	960 lbs
Cabinet with Chassis 24-36	53	53	85/93	72 single stacked	1450 lbs

Shipping Height 93" for 88" cabinet small and large  
 Cabinets can be mixed on some loads  
 88" Cabinets cannot have stands factory assembled, must ship loose or units must ship horizontal.

Description	Number of Cabinets per Pallet	Pallet			Up to 110" Long Riser Approx. Quality per 48 foot open Flatbed Trailer	111" to 120" Long Riser Approx. Quality per 48 foot open Flatbed Trailer	Approximate Weight per Pallet
		Length	Width	Height			
		Cabinet 09-18	4	*			
	8	*	50	88	60	48	1600 lbs
Cabinet 24-36	3	*	30	87	45	36	800 lbs
	6	*	59	87	45	36	1600 lbs

\*- For length of pallet add 5" to riser length

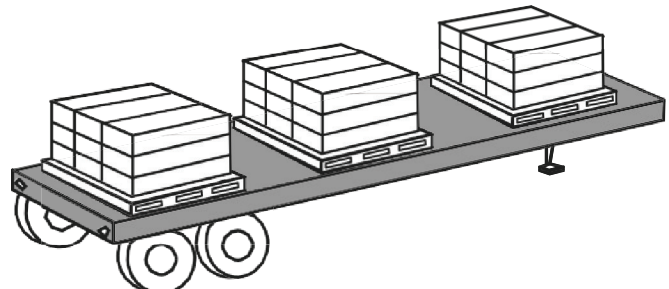
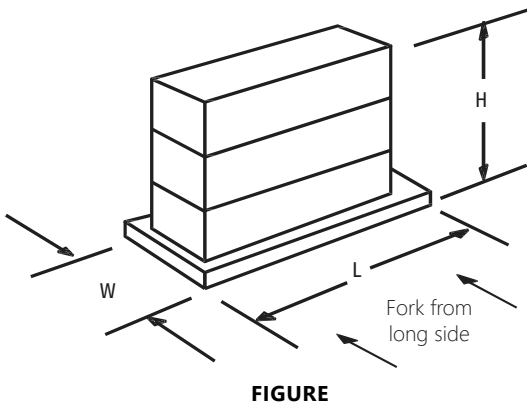



AE-Air  
P.O. Box 270969 - Dallas, Texas 75227  
Ph. (214) 388-5751 | Fax (214) 388-2255  
[www.ae-air.com](http://www.ae-air.com)

JUNE 2024