



HRCX

Water Source Heat Pump



Vertical Hi-Rise

3/4 thru 3 Tons

13.0 & 16.0 EER

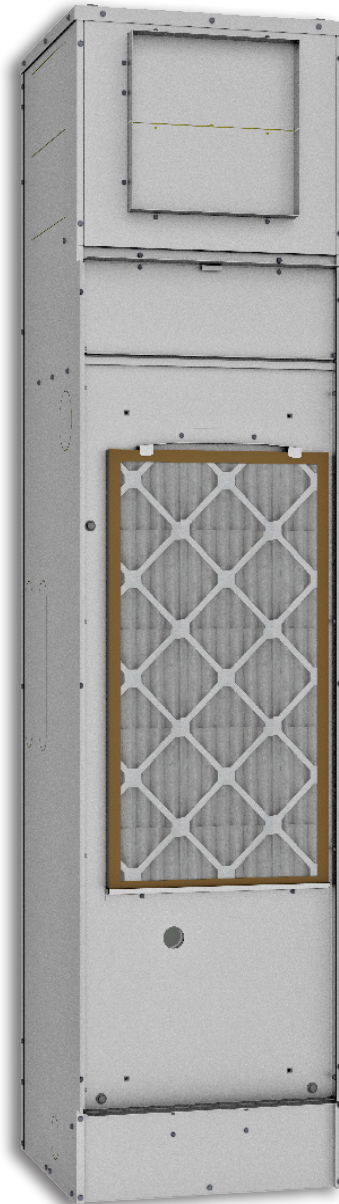

R454B

NOMENCLATURE

Cabinet

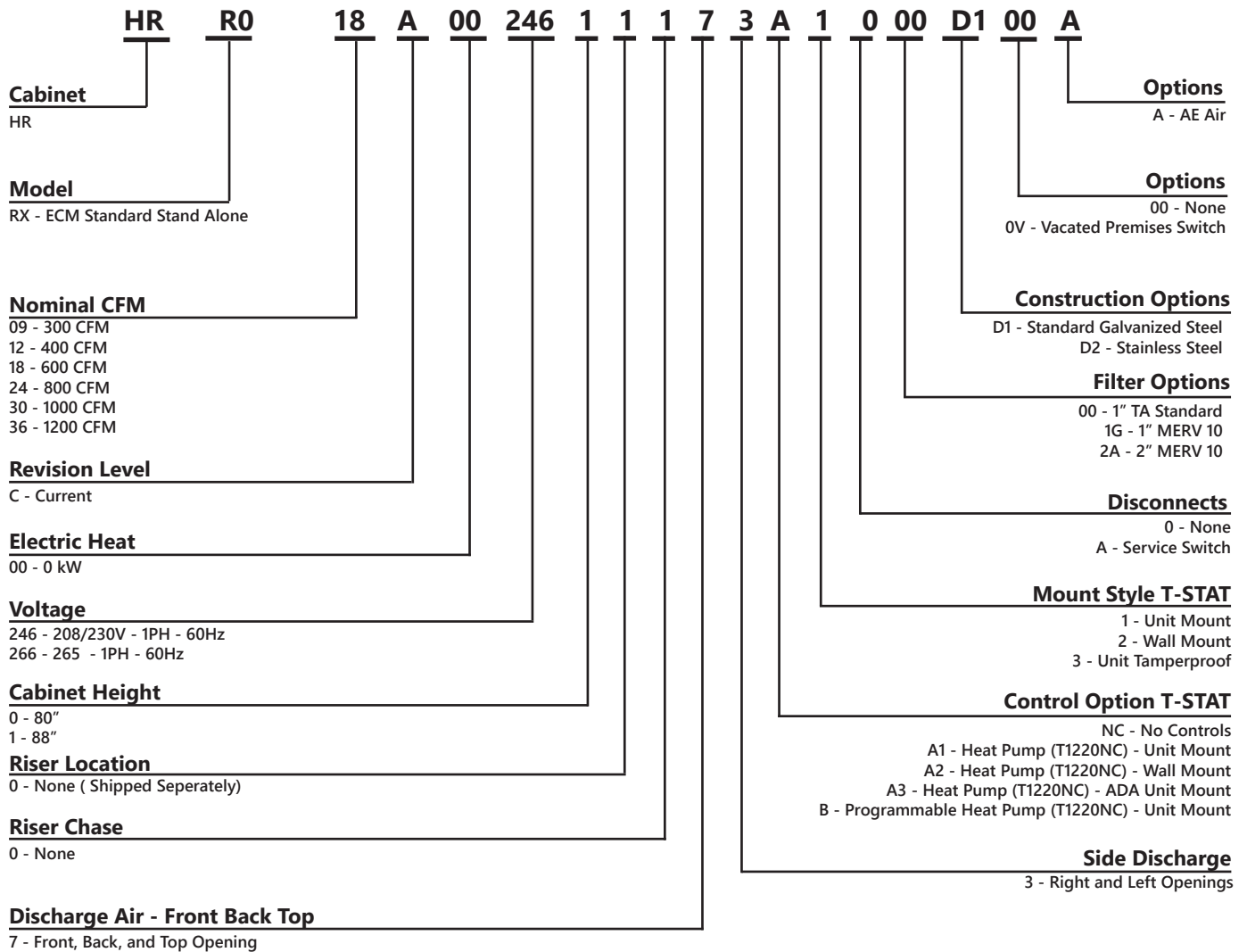

NOMENCLATURE

Chassis

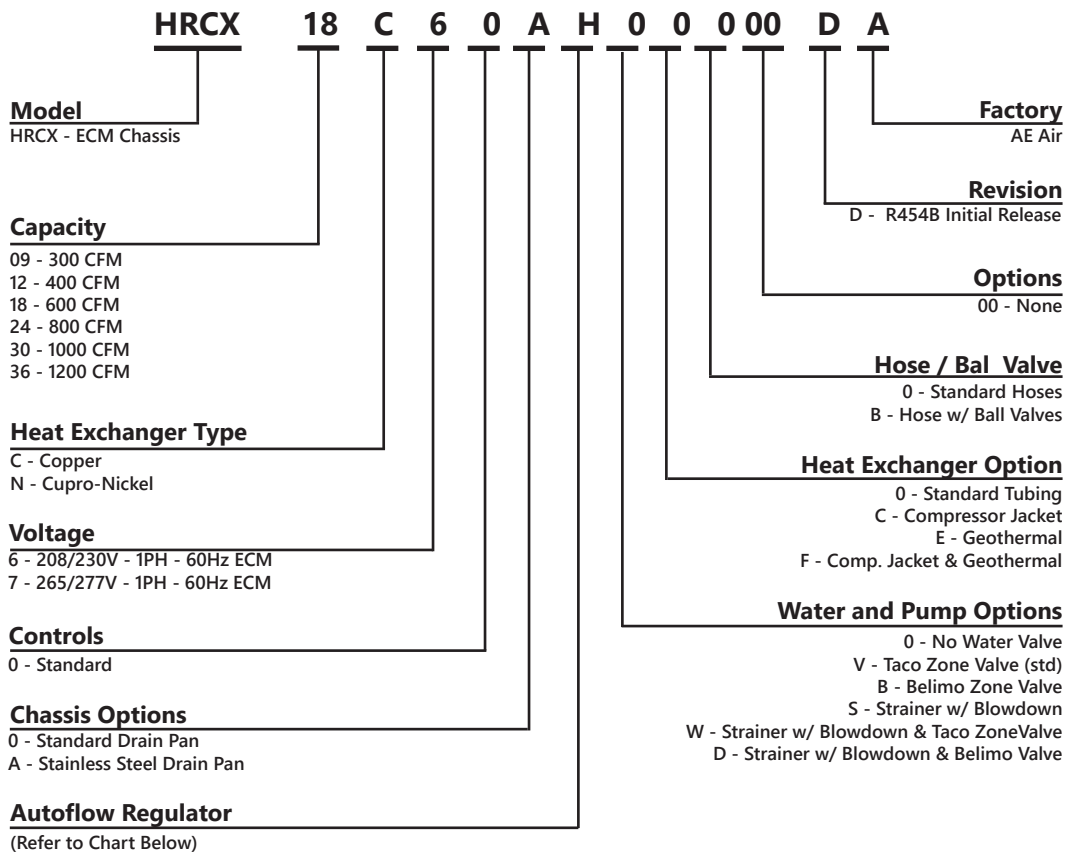

Auto-Flow Regulator (GPM) Code								
Tube		5/8" Sweat		7/8" Sweat				
Unit		09	12	18	24	30	36	
0	0	No Flow Regulator						
C	1.5	1.5						
D	2.0	2.0	2.0					
E	2.5	2.5	2.5					
F	3.0	3.0	3.0	3.0				
G	3.5		3.5	3.5				
H	4.0			4.0	4.0			
I	4.5			4.5	4.5			
J	5.0			5.0	5.0	5.0		
K	5.5				5.5	5.5		
L	6.0				6.0	6.0	6.0	
M	6.5				6.5	6.5	6.5	
N	7.0				7.0	7.0	7.0	
P	7.5					7.5	7.5	
Q	8.0					8.0	8.0	
T	9.0						9.0	
V	10.0						10.0	

GUIDE SPECIFICATIONS

General - Equipment shall be completely assembled, piped, internally wired, fully charged with R-454B refrigerant and test operated at the factory. Filters, thermostat field inter face terminal strip, and all safety controls are furnished and factory installed. The 3-ton and below equipment shall contain ETL, CETL and ISO –ARI 13256-1 listings and labels prior to leaving the factory.

Unit Cabinet - The structural integrity of the cabinets shall remain unaffected by the removal of any or all access panels. Fabricated from a minimum of 18 gauge galvanized steel. Access for inspection and cleaning of the unit drain pan, coils and fan section shall be provided. The unit shall be installed for proper access.

Cabinet Stand (OPTION) - Heavy gauge galvanized sheet metal stand field-attached to bottom of cabinet, Contact factory.

Cabinet Insulation - The insulation meets the erosion requirements of UL 181. The cabinets are insulated with 3/4" FSK, 1.8 scf density, Temperature Limit 350° (177°C) (unfaced), meets requirements of ASTM C1071, type 1 rolls. Fire hazard: 25/50 Flame/Smoke Developed Ratings (per ASTM E84, UL723, and CAN/ULC S102-M88).

Cabinet Construction for Surface Mounted Thermostat - Cabinet has pre-wired 2 x 4 x 1 7/8 deep electric box mounted for horizontal thermostat. Contractor must turn prior to dry walling if field-supplied vertical thermostat is used. Wire harness ends with 9-Pin Molex quick connector for easy connection to factory provided thermostats or can be cut off. See Cabinet decoder.

Discharge arrangements - Field selectable discharge air arrangements with knockout on all 4 sides of unit cabinet.

Filter Section - Includes 1" disposable type fiberglass filters and premium extruded rubber gasket on panel.

2" Filter (Option) - 2" filter improves air filtration and reduces maintenance.

Accessory Filters (Not available for every application - check blower table for ESP)

- 1" thick, MERV 8, and MERV 11
- 2" thick, MERV 8, MERV 11, MERV 13

Drain Pans - The condensate pan is constructed of corrosion resistant material. The bottom of the drain pan is sloped on two planes which pitches the condensate to the drain connection. Each drain pan includes an electronic condensate overflow switch.

Sound Attenuation (Option) - Provide a heavy duty, insulated compressor cover that reduces unwanted compressor noise (DUE TO ACCESS), this option must be field installed on the unit before unit is installed).

Blower Assemblies - Wheels are double width, double inlet (DWDI), forward curved, centrifugal type. They are statically and dynamically balanced for a smooth, quiet operation. The Class I housing is constructed of heavy gauge steel with die-formed inlet cones.

DC Motors (ECM) - Three motor leads connect directly to the control board. Gray is a 50% speed used when only "fan" is selected. Violet and White are the ramp up speeds used when in normal heating or cooling modes. See wiring diagram for proper speed tap selection.

GUIDE SPECIFICATIONS

Continued

Copper Coaxial Heat Exchanger - Features a tube in tube coaxial water-to-refrigerant heat-exchanger and constructed of a convoluted copper (optional Cupro-Nickel) inner tube and steel outer tube with a designed refrigerant working pressure of 450 PSIG (3100 kPa) and designed water side working pressure of no less than 400 PSIG (2750 kPa)

Compressor - Units contain a high efficiency rotary, scroll compressor. External vibration isolation is provided by rubber mounting devices located underneath the mounting base of the compressor. Internal thermal overload protection is provided. Protection against excessive discharge pressure is provided by means of a high pressure switch. A loss of charge is provided by a low pressure safety switch.

Reversing Valve - A system reversing valve (4-way valve) is included with all heating/cooling units. This valve is piped to be energized in the cooling mode to allow the system to provide heat if valve failure were to occur. Once the valve is energized for cooling, it will remain energized until the control system is turned to the OFF position, or a heating cycle is initiated.

Evaporative Coils - R-454B Refrigerant with TXV metering device - 3/8" inch staggered tube type construction with seamless copper tubes, and deep corrugated aluminum fins with straight edges. Fins are manufactured with full depth collars, drawn in the fin stock to provide accurate control of fin spacing and completely cover the copper tubes to lengthen coil life. The tubes are mechanically expanded into the fins for a permanent primary to secondary surface bond, assuring maximum heat transfer efficiency. Coil includes moisture carryover diffuser. Internally finned, 3/8-inch copper tubes mechanically bonded to a configured aluminum plate fin shall be standard. Coils shall be leak tested at the factory to ensure the pressure integrity. The coil shall be leak tested to 450 psig and operating pressure tested to 650 psig. The tubes are to be completely evacuated of air and correctly charged with proper volume of refrigerant prior to shipment. The refrigerant coil distributor assembly shall be of orifice style with round copper distributor tubes. The tubes shall be sized consistently with the capacity of the coil.

Electrical - The unit control box shall contain all necessary devices to allow heating and cooling operation to occur from a remote wall thermostat. Unit to include a control module that controls the units operation and monitors the safety controls that protect the compressor, heat ex-changer, wiring and other components from damage caused by operating outside of design conditions.

- **24V Status LED** - Green light indicates 24V power to the control module.
- **50 VA Transformer** - Assists in accommodating accessory loads.
- **Anti-short Cycle Timer, Alarm Relay** - Activated if the unit locks out.
- **Condensate Overflow Lockout** - Consist of an electronic sensor mounted to the drain pan. When condensate pan liquid reaches an unacceptable level, the unit is automatically deactivated and placed in a lockout condition.
- **Random Restart Timer** - Unit provided with a random restart timer to ensure a random delay in energizing each different HRC unit to minimize peak electrical demand during start-up from different operating modes or after building power outages.
- **Nuisance Trip Protection** - Unit shall attempt to start up to three times with a fault signal. If the fault continues, the unit locks out.

GUIDE SPECIFICATIONS

Continued

- **Digital Control Module (DCM)** - Controls unit operation and monitors all safety controls. (Patent Pending)
- **Accessory Relays (2)** - Relays can be selected to cycle with either the fan or compressor. Relay "1" can be configured for use with slow opening water valves (60 second pre-compressor initialization) and relay "2" can be configured for a 30 second post fan delay.
- **Test Mode** - Test pins can be momentarily jumped to enter into a 10 minute test mode period in which all time delays are sped up to 15 times. While in the test mode the LED Display will display a code representing the last fault in memory.
- **High Pressure Switch** – Located on the discharge line of the refrigeration circuit.
- **Low Pressure Switch** – Located on the suction line of the refrigeration circuit.
- **Low Temperature Cutout Sensor** – Located on the heat exchanger to prevent unit operation below low temperature setting.
- **Condensate Overflow Switch** – Sensor located in the drain pan to prevent overflow.
- **Over / Under Voltage Shutdown** - Should an Over / Under Voltage condition be detected, the module will initiate a shutdown. Over / Under Voltage Shutdown is a in that if the voltage comes back with range of 18.5VAC to 31VAC, then normal operation will be restored.
- **Vacated Premises Control (VPC) (OPTION)** - The vacated premises operation is designed for extended periods of non-occupancy when the occupant desires the heat pump to operate in the cooling mode for a predetermined cycle time to help control indoor air conditions.
 - **HOME selection** - if the switch is in the HOME position the heat pump will operate in its normal mode.
 - **AWAY selection** - if the switch is in the AWAY position and the thermostat is set to the "COOL" mode the heat pump will operate in accordance to the thermostat setting.

Additionally the heat pump will cycle on in the cooling mode for 15 minute run times either 4 or 8 times per day depending on Dip 1.7 selection. (See Installation Instructions). This option also includes an automatic reset feature. If a fault occurs, the system will shut down, but then automatically reset every 24 hours. If the same fault exists each day, the unit will lockout on the fourth day and have to be manually reset.

Field selectable settings:

- **5 Second Compressor Delay** - Blower starts before the compressor, attenuates compressor start up sound.
- **45 Second Blower-off Delay** - Increases cooling efficiency.
- **Continuous Dehumidification Mode** - Selects continuous low speed fan operation for increased humidity removal, with Dip switch 1.4.

Thermostat Wiring Harness (WHIP) (OPTION) - Low voltage wire harness 15, 25, or 35 foot ending with 9-Pin Molex quick connector. Exits cabinet on top, left front corner. Thermostat cable is rated CL-2. See Cabinet decoder. Can be encased in BX conduit as special, contact factory.

GUIDE SPECIFICATIONS

Continued

Water Loop Valve Package Components – OPTIONAL Valve packages are available and can be configured with the following components to meet specific specifications:

- **FH - Flexible Hoses (STANDARD)** enable the Supply and Return water connections between the Unit and the water Loop Risers. The two stainless steel FH are made of a stainless-steel outer braid with an inner core of tube made of a nontoxic synthetic polymer material. Fire rated materials per ASTM E84-00 (NFPA 255, ANSI/UL 723 & UBC 8-1). The FH terminations are swivel MPT (Male Pipe Thread) fitting at one end and at the opposite end with a NPSH thread connector (internal thread) sealed with a fiber or EPDM washer, shipped inside the connection. Swivel connection provides union between chassis and risers. The FH have a max working pressure of 400 PSI, temperature operating range of 15°F to 180°F however operation below 32°F requires antifreeze.

- **AWBV - Automatic Water Balancing Valve (OPTIONAL)** regulates the amount of water into each unit to enable a proper Water System balance. The AWBV is provided from the factory at specific selectable flow rates and automatically controls the water flow to within 10% of the rated value over a 40 to 1 differential pressure, and operating range (2 to 80 PSID). The AWBV has an operating pressure rate of XX psi with a temperature range of 32 to 225°F, and a pressure differential range of 2 to 80 PSID. The AWBV is manufacture with precision sculptured brass and a polyphenylsulfone orifice with an elastomeric diaphragm. The valve body shall be construct from hot forged brass UNS C37700 per ASTM B-283 latest revision.

- **ST - Strainer (OPTIONAL)** – The ST valve body is constructed from dezincification resistant brass with a 600 PSI and a max working temperature of 325°F. The ST filter screen is made of a 20-mesh screen constructed of 304 stainless steel and removable via a cap with an FKM sealing O-Ring. The ST cap has a ¼" or ½" FNPT Port to which a blowdown ball valve is attach including a hose bib threaded connection and cap.

- **IBV - Isolation Valves (OPTIONAL)** - Isolation ball valves mounted between the unit and the supply and return lines of the loop to isolate the water flow to the unit in a maintenance or service situation. The IBV are rated to 600 psi non-shock cold working pressure. Full port, two-piece body with blowout-proof stem and PTFE Seats. ASME B16.33: 125 psig (maximum) and operating temperature of -4°F to 194°F.

- **MCV - Motorized Control Valves (OPTIONAL)** – The MCV actuator is easily removed, ON/OFF type, 2-way, normally close with a spring close actuation and actuates with a 24VAC control signal. The MCV valve comes in two options. MCV Option 1 valve body can operate at a maximum operating pressure of 360 psi, a maximum pressure differential of 75 PSI, operating with fluid temperatures between 36°F to 212°F and a max glycol percentage allowable of 60%. MCV Option 2 valve body can operate at a maximum operating pressure of 300 psi, a maximum pressure differential of 125 PSI, operating with fluid temperatures between 20°F to 220°F and a max glycol percentage allowable of 50%.

PHYSICAL DATA

HRCX

MODEL - SIZE	HRCX	9	12	18	24	30	36
Compressor (1 Each)	1 Each	Rotary			Scroll		
Refrigerant Type		R454B					
Factory	(Lb.) [oz.]	1.7 [27]	2.7 [43]	2.7 [43]	3.7 [59]	3.7 [59]	3.6 [57]
Motor	Type	ECM					
	Speeds	Multiple					
	HP [kw]	1/4 [.18]	1/4 [.18]	1/3 [.24]	1/3 [.24]	1/2 [.37]	1/2 [.37]
Blower Wheel (Dia. x W)	(Dia x W) in. [cm]	6.75 x 7 [17.15 x 17.78]			9 x 7 [22.86 x 17.78]		10 x 8 [25.4 x 20.32]
COAX Volume	(US Gallons)	0.116	0.116	0.144	0.544	0.544	0.544
Condenser Water Connections	(in)	1/2	1/2	3/4	1	1	1
Condensate Connection	I.D.(in) / O.D.(in)	7/8 / 1-1/8					
Air Coil Dimension	(W x H) in. [cm]	14 x 28 [5.5 x 11.0]			18 x 30 [7.1 x 11.8]		
Standard TA Filter 1"	(W x H) in. [cm]	16 x 30 [6.3 x 11.8]			20 x 32 [7.9 x 12.6]		
Operating Weight		Weight					
Chassis	Lb. [kg]	125 [57]	128 [58]	131 [59]	182 [83]	185 [84]	188 [85]
80" Cabinet		128 [58]			173 [78]		175 [79]
88" Cabinet		143 [65]			188 [85]		190 [86]

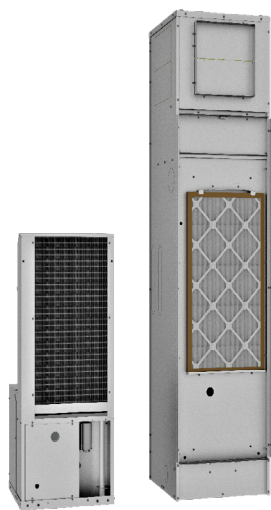

HRCX CHASSIS AND HR CABINET

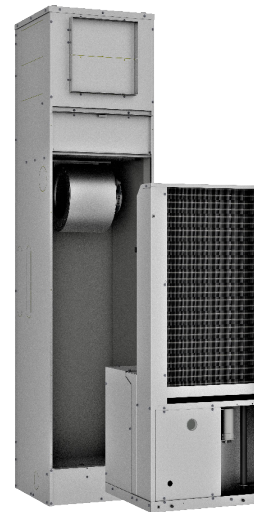

SLIDE IN HRCX CHASSIS TO HR CABINET

HRCX CHASSIS FULLY INSULATED PIPING FOR GROUND LOOP APPLICATIONS



HRCX CHASSIS UN-INSULATED PIPING FOR STANDARD WATER CONDITIONS



ELECTRICAL DATA

ECM - ELECTRICAL DATA 208/230V-1-60							
MODEL NUMBER	VOLTAGE	COMPRESSOR		BLOWER		MIN. CIRCUIT AMPACITY	MAX. CIRCUIT PROTECTION
		RLA	LRA	FLA	HP		
HRCX09	208/230V-1-60	3.7	22	2.3	1/4	7	15
HRCX12	208/230V-1-60	4.7	25	2.3	1/4	9	15
HRCX18	208/230V-1-60	7.0	38	2.8	1/3	12	15
HRCX24	208/230V-1-60	10.9	62.9	2.8	1/3	17	25
HRCX30	208/230V-1-60	12.8	67.8	4.1	1/2	21	30
HRCX36	208/230V-1-60	15.4	82.6	4.1	1/2	24	35

ECM - ELECTRICAL DATA 265V-1-60							
MODEL NUMBER	VOLTAGE	COMPRESSOR		BLOWER		MIN. CIRCUIT AMPACITY	MAX. CIRCUIT PROTECTION
		RLA	LRA	FLA	HP		
HRCX09	265V-1-60	3.5	22	2.3	1/4	7	15
HRCX12	265V-1-60	4.2	22	2.3	1/4	8	15
HRCX18	265V-1-60	6.0	30	2.6	1/3	11	15
HRCX24	265V-1-60	9.0	54	2.6	1/3	14	20
HRCX30	265V-1-60	11.2	60	3.6	1/2	18	25
HRCX36	265V-1-60	12.2	72	3.6	1/2	19	30

BLOWER DATA

ECM BLOWER DATA						
MODEL NUMBER	FAN SPEED	CFM vs EXTERNAL STATIC PRESSURE				
		0.1	0.2	0.3	0.4	0.5
HRCX09*	High	430	410	380	360	340
	Med	360	330	300	280	250
	Low	290	260	230	---	---
HRCX12*	High	490	460	440	420	410
	Med	390	360	340	310	290
	Low	310	280	250	230	---
HRCX18*	T3	770	740	700	660	610
	T2	650	620	590	560	530
	T1	550	520	490	450	410
HRCX24*	T3	940	910	870	840	800
	T2	840	810	770	740	700
	T1	720	690	650	610	560
HRCX30*	T3	1260	1210	1140	1060	970
	T2	1080	1050	1020	980	940
	T1	990	960	930	900	870
HRCX36*	T3	1300	1230	1150	1080	990
	T2	1260	1210	1140	1060	970
	T1	1080	1050	1020	980	940

Note:
CFM rated at 208V for 208-230V units

DIMENSIONS

80" Tall Cabinet

Unit Size: 09, 12, & 18

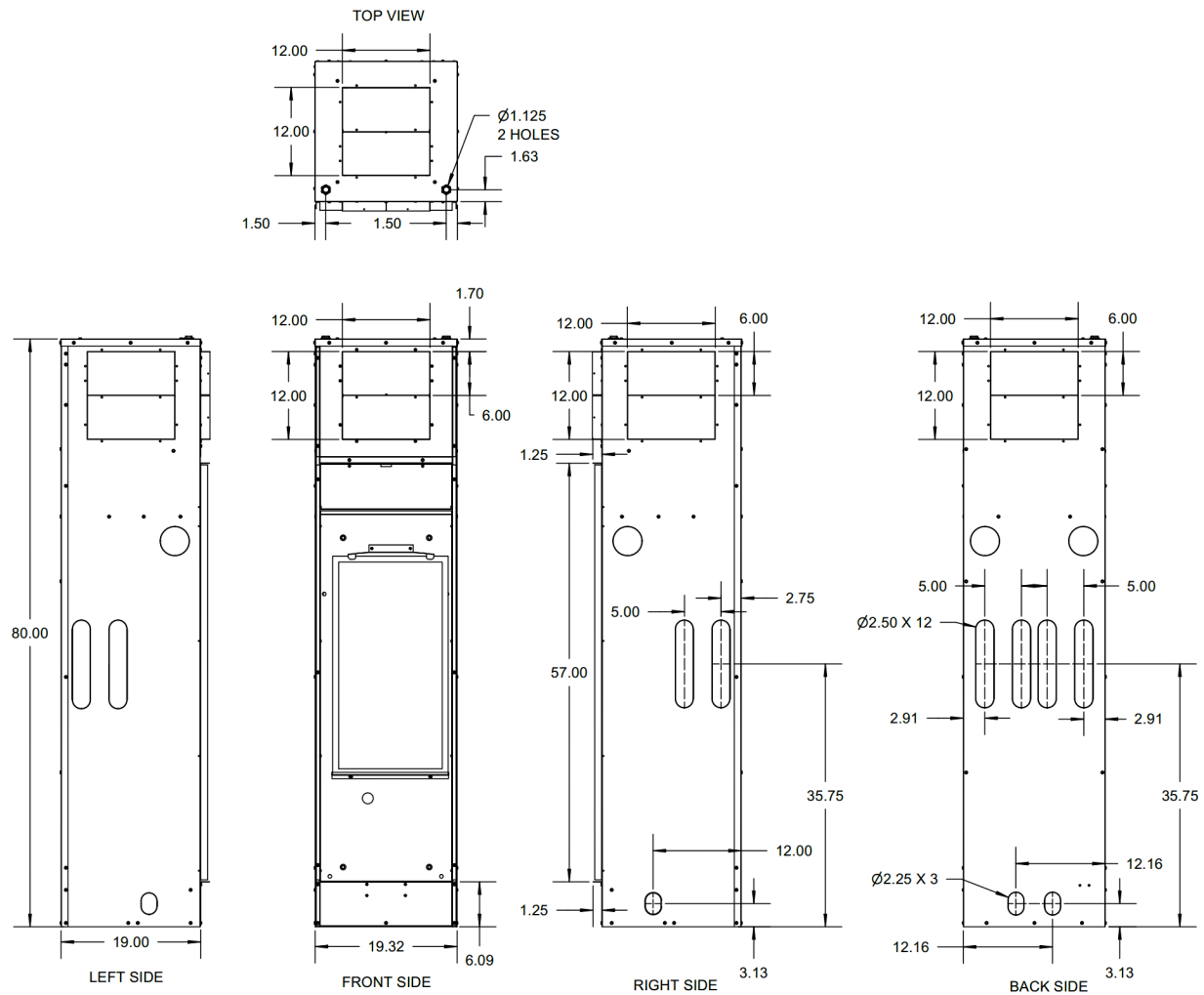

HT Vertical High Rise Heat Pump Cabinet

NOTES:

1. All dimensions are in inches.
2. The return air/control box side is defined as front of cabinet. Supply air K.O.'s and riser K.O.'s are on all panels. Supply air grilles can be on any side except riser side.
3. Units with 24v surface mount T/stat option have 2x4 box factory installed in horizontal position. Contractor must turn box before dry walling if customer is using vertical thermostat type.
4. Cabinet shown is Style 3, risers back right.
5. Supply air K.O.'s have to be field removed.
6. Supply air angles are shipped loose. Break off for 6" or 8". Position inside and attach with screws.
7. Service clearances: Front requires 24" from finished wall plus 4" added to cabinet width.

DIMENSIONS

88" Tall Cabinet

Unit Size: 09, 12, & 18

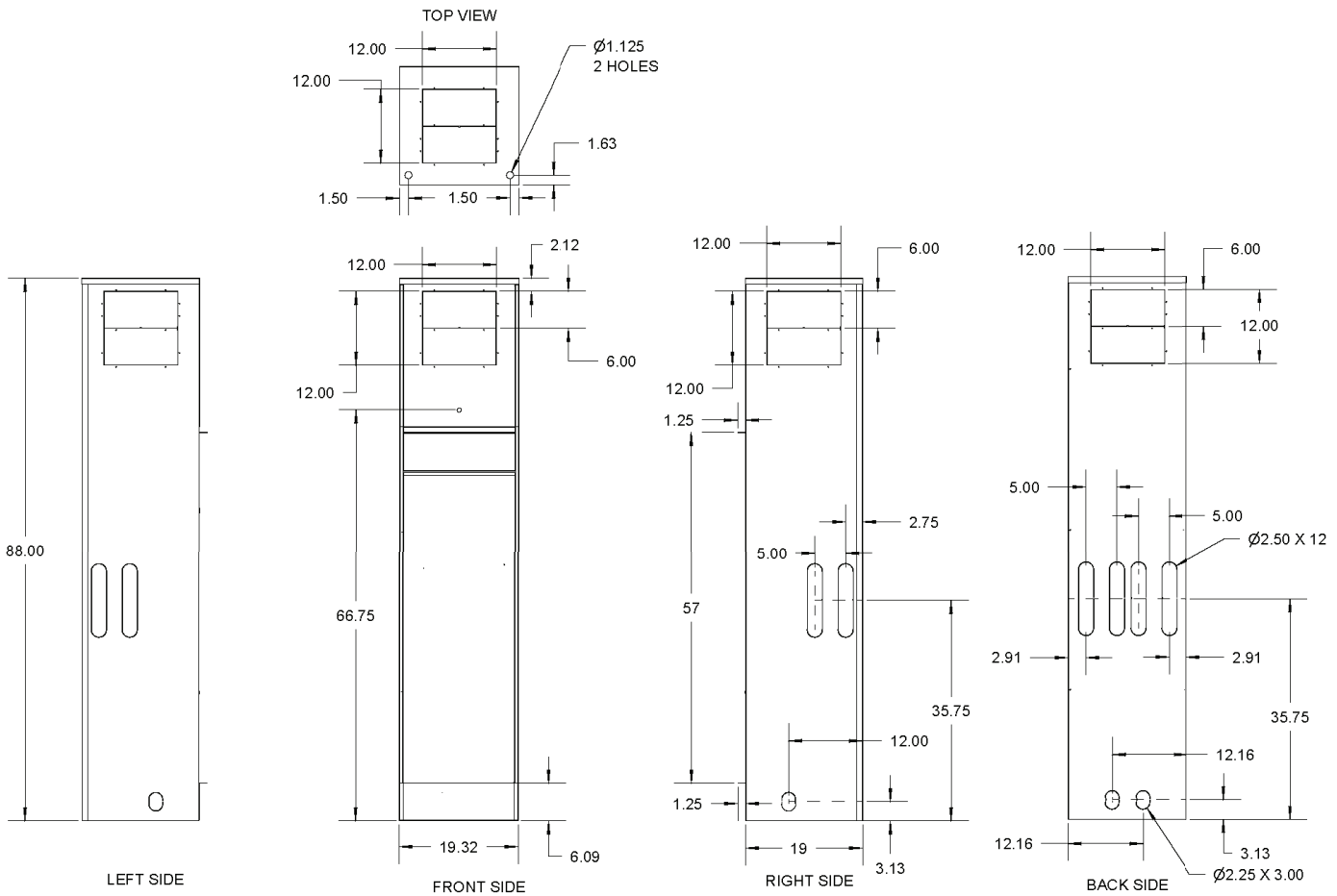

HT Vertical High Rise Heat Pump Cabinet

NOTES:

1. All dimensions are in inches.
2. The return air/control box side is defined as front of cabinet. Supply air K.O.'s and riser K.O.'s are on all panels. Supply air grilles can be on any side except riser side.
3. Units with 24v surface mount T/stat option have 2x4 box factory installed in horizontal position. Contractor must turn box before dry walling if customer is using vertical thermostat type.
4. Cabinet shown is Style 3, risers back right.
5. Supply air K.O.'s have to be field removed.
6. Supply air angles are shipped loose. Break off for 6" or 8". Position inside and attach with screws.
7. Service clearances: Front requires 24" from finished wall plus 4" added to cabinet width.

PRIMARY/SECONDARY CABINET INSTALLATION

TOP VIEW

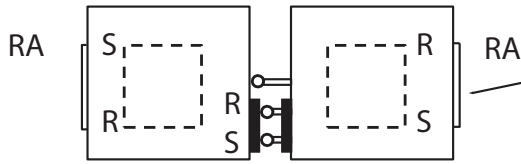

Field connect hoses in both cabinets supply to supply and return to return (Cabinet supply is closest to corner, chassis supply is on left facing air coil)

SIDE VIEW

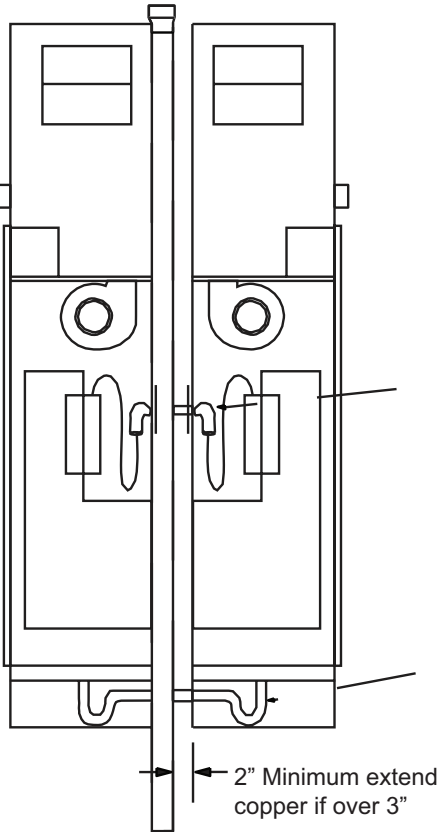

Field braze valve package (shut off with tubing)

Field install P-Trap and Clamp both ends

2" Minimum extend copper if over 3"

When cabinets are pushed up to risers allow sufficient clearance. Shutoffs should be inside cabinet.

TOP VIEW

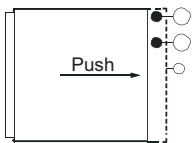

Step 1
Risers Opposite
Return Air Opening

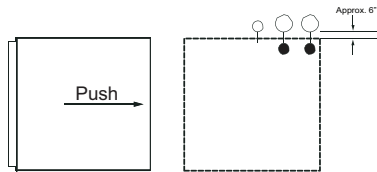

Step 1
Risers Adjacent to
Return Air Opening

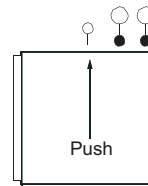

Step 2

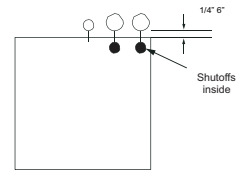

**Final
Cabinet Position**

VALVE PACKAGES & ACCESSORIES

Cabinet Configurations

Air Flow Configuration

NONE

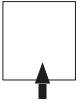

Right Side

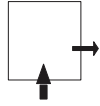

Left Side

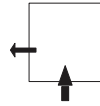

Left & Right Sides

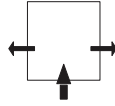

Back



Back & Right

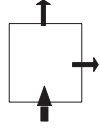

Back & Left

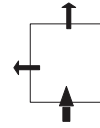

Front

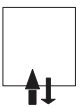

Front & Right

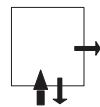

Front & Left

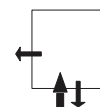

Front, Left & Right

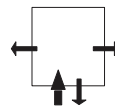

Top

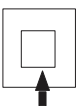

Top & Right

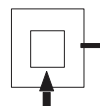

Top & Left

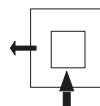

Top, Left & Right

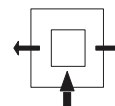

Top & Back

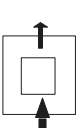

Top, Back & Right

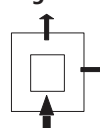

Top, Back & Left

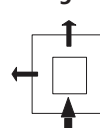

Top & Front

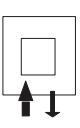

Top, Front & Right

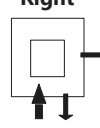

Top, Front & Left

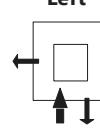

Front & Back



Front, Back & Right

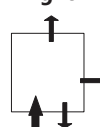

Front, Back & Left

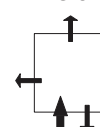

Front, Back & Top

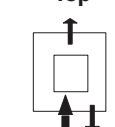

↑ = RETURN AIR (AIR ENTERING CABINET)

↑ = SUPPLY AIR (AIR LEAVING CABINET)

NOTES:

1. Front is return air side and control box location.
2. Risers can be on any side without return or supply air openings.
3. All sides and top have KO's.

ACCESS RETURN PANEL

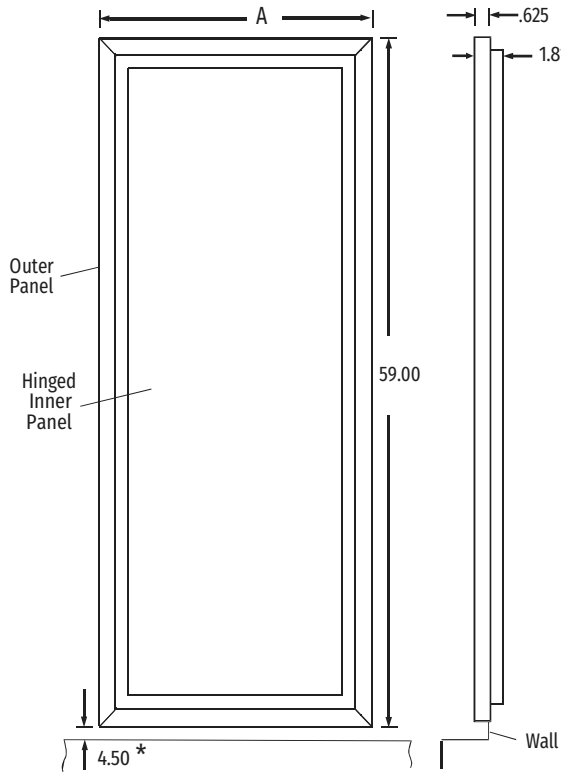
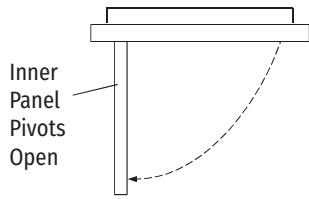

From Floor Surface
* - Dimension increases if cabinet is on stand or pad

Front View
Standard Panel



Optional Inner solid panel

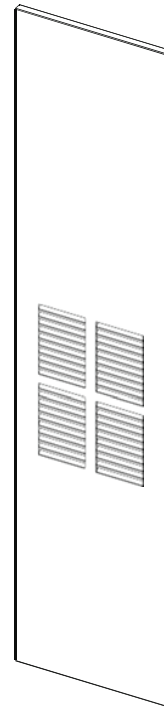

Optional Inner panel with Grille (Stamped Louvers)

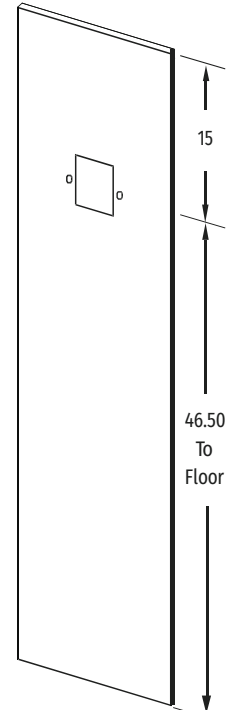

Optional Inner Panel with holes to mount ADA Thermostat

Unit	A	PANEL PART NUMBERS		
09-18	21.50	09-18 SIZE	9PWHR01	HINGED - SOLID
24-36	25.50	24-36 SIZE	9PWHR02	HINGED - SOLID
		09-18 SIZE	9PWHR03	HINGED - LOUVERED
		24-36 SIZE	9PWHR04	HINGED - LOUVERED
		09-18 SIZE	9PWHR05	HINGED - ADA MOUNT ACCESS
		24-36 SIZE	9PWHR06	HINGED - ADA MOUNT ACCESS
		09-18 SIZE	9PWHR07	HINGED - CAM LOCK
		24-36 SIZE	9PWHR08	HINGED - CAM LOCK

NOTES:

1. Dimensions are in inches.
2. Panel powder coated ceiling white.
3. Inner panel pivots open 90°, for filter replacement without removing panel.
4. Shipped as left-hand pivot.

CABINET PLATFORMS SPECIFICATIONS

- 12" tall
- 16 Gauge galvanized steel
- Attached to cabinet with 4 screws
- Field installed

Unit	A	B	C
09-18	18.86	18.25	12
24-36	23.86	23.25	

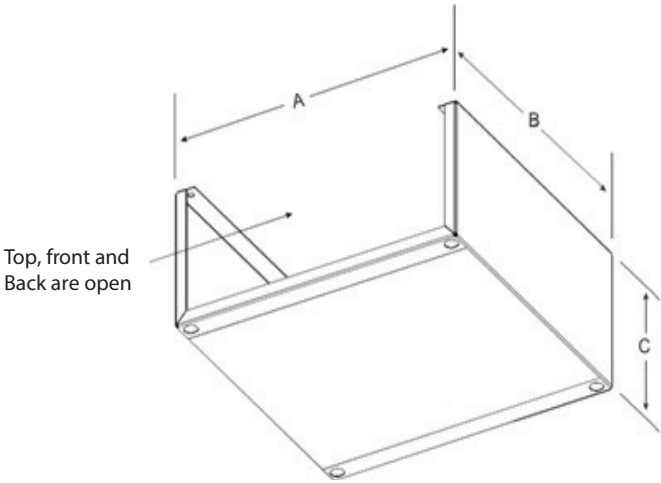

DISCHARGE AIR OPENINGS

DISCHARGE AIR OPENINGS (Any Combination, Top and Sides, Grilles or Ductwork)				
Unit Size	1 Opening	2 Openings	3 Openings	4 or more Openings
9FHR,12FHR	12" x 12"	12" x 6"		
18FHR		12" x 12"	12" x 6"	
24FHR		16" x *	16" x **	
30FHR		16" x *	16" x **	
36FHR		16" x *	16" x **	

* - 88" CABINET = 16"
** - 88" CABINET = 8"

Standard cabinet openings and grille sizes. (W x H)

88" cabinet models 09-18

front, back, or sides 12 x 12 or 12 x 6 and top 12 x 12.

88" cabinet models 24-36

front, back, or sides 16 x 16 or 16 x 8 and top 16 x 16.

NOTES:

1. When selecting supply air openings/grilles consider CFM, velocity (throw), added static pressure and sound.
2. If custom grille sizes are used - area should be greater or equal to above.
3. If using more than recommended number of opening, total CFM may be reduced or be unstable (PSC or ECM Motor).

Important!

Top air discharge units will require turning vanes and/or a volume damper for proper air flow and balancing, to minimize turbulence. These components must be field furnished and installed in accordance with SMACNA guidelines.

GRILLES

Grilles are shipped loose for field installation after drywall has been finished.

Grilles are brushed aluminum or painted (White).

Overall dimensions - add 1.25 to nominal dimensions.

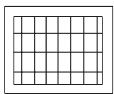

1.88

Single Deflection- Adjustable vertical blades for controlling horizontal path of discharge air (Left/Right).

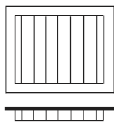

Double Deflection- Adjustable vertical and horizontal blades for controlling horizontal and vertical path of discharge air. (Left/Right and Up/Down) Recommended for all standard applications.

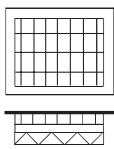

3.25

Double Deflection with Opposed Blade Damper- Addition of opposed blade damper to grille allows control of air volume (CFM) and path of discharge air. Recommended for applications requiring unequal air flow or side discharge grille(s) with additional top discharge air opening.

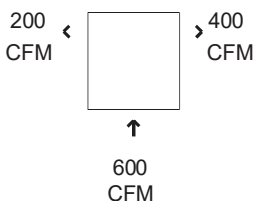

Unequal Air Flow - Air discharges requiring different air volumes (CFM). Use double deflection with opposed blade damper grills.

Nominal Grille Size	Double Deflection Free Area (Sq. Ft)		
	Deflection 0°	Deflection 22 1/2°	Deflection 45°
12 x 6	0.30	0.28	0.22
12 x 12	0.65	0.59	0.48
16 x 8	0.61	0.55	0.44
16 x 12	0.93	0.85	0.68
16 x 16	1.25	1.12	0.90

PACKAGING AND SHIPPING OPTIONS

Units Are Shipped FOB Factory

1. Upright in carton 4 per pallet, see figure 1.

Cabinet without risers attached can ship upright 4 per pallet, see figure 1.

Cabinets are palletized to maximize shipping density then grouped by unit size, building, and floor where possible. Pallets are stretch wrapped and flatbed load is tarped for protection. Special shipping accommodations can be provided. Request added cost before quoting job, shipping cost could increase significantly and any additional charges will be billed. Some examples include, end fork pallets, reduced number of units per pallet, palletized specifically by riser, by floor, or over crating.

Vertical Shipping					
Description	Per 4 pack on pallet			Approx. Quantity Per 53 foot Box Trailer	Approximate Weight per Pallet
	Length	Width	Height		
Chassis 09-18	40	40	50	120 single stacked	500 lbs
Chassis 24-36	50	48	52	96 single stacked	750 lbs
Chassis 09-18	40	40	100	240 single stacked	500 lbs
Chassis 24-36	50	48	104	192 single stacked	750 lbs
Secondary Cabinet 09-18	43	43	85/93	112 single stacked	450 lbs
Secondary Cabinet 24-36	53	53	85/93	72 single stacked	700 lbs
Cabinet with Chassis 09-18	43	43	85/93	112 single stacked	960 lbs
Cabinet with Chassis 24-36	53	53	85/93	72 single stacked	1450 lbs

Shipping Height 93" for 88" cabinet small and large
 Cabinets can be mixed on some loads
 88" Cabinets cannot have stands factory assembled, must ship loose or units must ship horizontal.

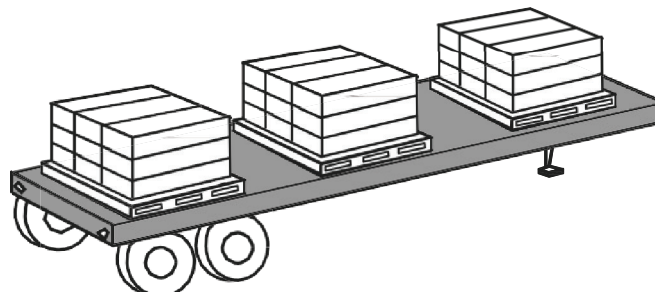
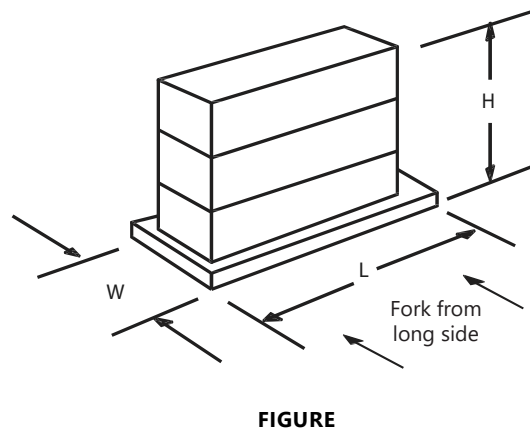
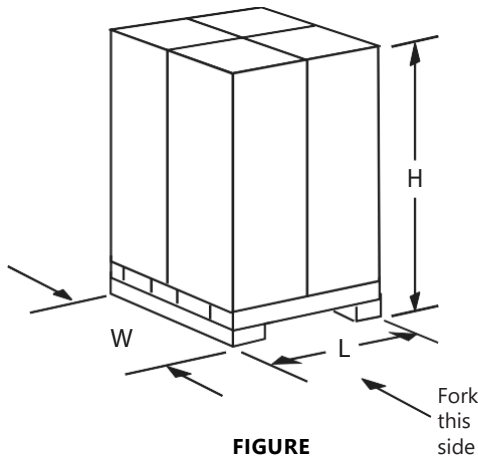



AE-Air
P.O. Box 270969 - Dallas, Texas 75227
Ph. (214) 388-5751 | Fax (214) 388-2255
www.ae-air.com

JUNE 2024

