

First Co.

Installation, Operation, & Maintenance Manual

IOM 79H01
Rev. A 11/21

WSH(C,X) Horizontal Series Water Source Heat Pump

HydroTechTM
R-410A Water Source Heat Pump

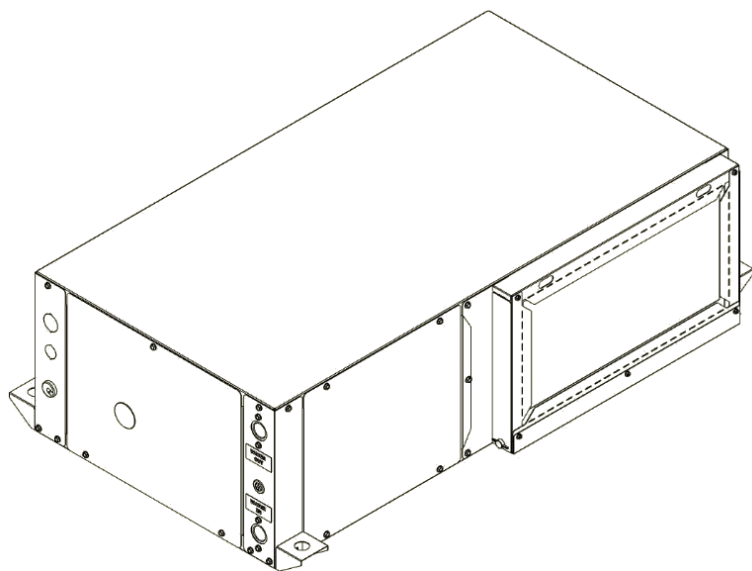

COPYRIGHT

First Co. works to continuously improve its products and as a result, it reserves the right to change design and specifications without notice.

The warranty may be void unless the Startup & Performance Checklist is completed and returned to the warrantor. If the HVAC unit is not installed properly, the warranty will be void, as the manufacturer cannot be held accountable for problems that stem from improper installation.

©2021 First Co., 8273 Moberly Lane, Dallas, TX 75227

*****WARNING TO INSTALLER, SERVICE PERSONNEL AND OWNER*****

Altering the product or replacing parts with non-authorized factory parts voids all warranty or implied warranty and may result in adverse operational performance and/or a possible hazardous safety condition to service personnel and occupants. Company employees and/or contractors are not authorized to waive this warning.

TABLE OF CONTENTS

SAFETY CONSIDERATIONS	4-5
MODEL NOMENCLATURE	6
GENERAL INFORMATION	7
INTRODUCTION	7
STORAGE	8
SHIPPING & PACKAGE LIST	8
UNIT INSPECTION CHECKLIST	9
UNIT DIMENSIONAL DATA	10-11
UNIT PHYSICAL DATA	11-12
ELECTRICAL DATA	12
INSTALLATION	13-18
REQUIREMENTS	13
INSTALLATION PRECAUTIONS	13
UNIT CLEARANCE REQUIREMENTS	14
MOUNTING DETAILS	15
TYPICAL MOUNTING INSTALLATION	16
FIELD CONVERSION	17
PIPING INSTALLATION	18
CONDENSATE DRAINAGE	18
ELECTRICAL	19
APPLICATION	20-21
CONTROLS	22-27
SEQUENCE OF OPERATIION	22
WSCM CONTROL MODULE	23
FIELD CONTROLLABLE FUNCTIONS	23-24
WSCM SAFETY FEATURES	24-27
CONTROL BOX DETAIL	27
BLOWER REMOVAL	28
PERFORMANCE DATA	29-31
BLOWER DATA	29
PRESSURE & TEMPERATURE DATA	30-31
WATER PRESSURE DROP DATA	31
WIRING DIAGRAMS	32-37
CIRCUIT SCHEMATIC	38
STARTUP INSTRUCTIONS	38-39
STARTUP & PERFORMANCE CHECKLIST INSTRUCTIONS	39
MAINTENANCE & SERVICE	40
TROUBLESHOOTING	41-42
SUPPORT/REFERENCE MATERIAL	43
STARTUP & PERFORMANCE CHECKLIST	44
NOTES	45

SAFETY CONSIDERATIONS





1. **READ THE ENTIRE MANUAL BEFORE STARTING THE INSTALLATION.**
2. These instructions are intended as a general guide and do not supersede national, state, or local codes in any way.
3. Altering the product, improper installation, or the use of unauthorized factory parts voids all warranty or implied warranty and may result in adverse operation and/or performance or may result in hazardous conditions to service personnel and occupants. Company employees or contractors are not authorized to waive this warning.
4. This product should only be installed and serviced by a qualified, licensed, and factory authorized installer or service agency.
5. All “kits” and “accessories” used must be factory authorized when modifying this product. Refer and follow instructions packaged with the kits or accessories when installing.



RECOGNIZE THE FOLLOWING SAFETY NOTATIONS THROUGHOUT THIS MANUAL AND POSTED ON THE EQUIPMENT:



 **DANGER** 

Indicates an imminently hazardous situation which, if not avoided, will result in death or serious injury.



 **WARNING** 

Indicates a potentially hazardous situation or unsafe practices that could result in severe personal injury or death and/or damage to property.

 **WARNING** 

 **ELECTRIC SHOCK HAZARD** 



This warning signifies potential electrical shock hazards that could result in personal injury or death.

 **CAUTION** 



The CAUTION symbol indicates a potentially hazardous situation that may result in minor or moderate injury.



 **IMPORTANT** 

Suggests important procedure steps to insure proper installation, reliability, or operation.

 **NOTE** 

Used to highlight suggestions, which may result in enhanced installation, reliability or operation.

 **WARNING** 

 **FIRE OR EXPLOSION HAZARD** 

Failure to follow safety warnings exactly could result in dangerous operation, serious injury, death or property damage.

Improper servicing could result in dangerous operation, serious injury, death or property damage.

- Before servicing, disconnect all electrical power to the WSH(C,X) water source heat pump.
- When servicing controls, label all wires prior to disconnecting. Reconnect wires correctly.

Verify proper operation after servicing.

SAFETY CONSIDERATIONS CONTINUED

CAUTION

Mechanical components and filters can become clogged with dirt and debris, which can cause damage to the system. The manufacturer does not warrant equipment subjected to abuse. Construction debris can void warranties and liability for equipment failure, personal injury, and property damage.

WARNING

Material in this shipment has been inspected at the factory and released to the transportation agency in good condition. When received, a visual inspection of all cartons should be made immediately. Any evidence of rough handling or apparent damage should be noted on the delivery receipt in the presence of the carrier's representative. If damage is found, a claim should be immediately filed against the carrier.

These models are designed for indoor installation only. Installation of this equipment, wiring, ducts, and any related components must conform to current agency codes, state laws, and local codes. Such regulations take precedence over general instructions contained in this manual.

WARNING

DO NOT USE FOR HEATING AND COOLING BUILDINGS OR STRUCTURE UNDER CONSTRUCTION!

WARNING

Improper installation, adjustment, alteration, service, or maintenance can cause property damage, personal injury or loss of life. Refer to the user's information manual provided with this water source heat pump. Installation and materials, service must be performed by a qualified installer, or service agency.

WARNING

Installation and service must be performed by a licensed professional installer (or equivalent), or service agency. Attempting to install or repair this unit without such background may result in product damage, personal injury or death.

WARNING

These instructions are intended as an aid to qualified, licensed service personnel for proper installation, adjustment and operation of this unit. Read these instructions thoroughly before attempting installation or operation. Failure to follow these instructions may result in improper installation, adjustment, service or maintenance possibly resulting in fire, electrical shock, property damage, personal injury or death.

WARNING



HIGH VOLTAGE!



Disconnect all power before servicing. Failure to do so may result in property damage, personal injury, or death.

CAUTION

Use care when handling compressors. Some surfaces could be hot!

CAUTION

Compressors should NOT be used to evacuate the air conditioning system. Vacuums this low can cause internal electrical arcing resulting in a damaged or failed compressor.

WARNING

The unit must be permanently grounded. Failure to do so can cause electrical shock resulting in severe personal injury or death.

WARNING

"USE COPPER SUPPLY WIRES ONLY!"

MODEL NOMENCLATURE

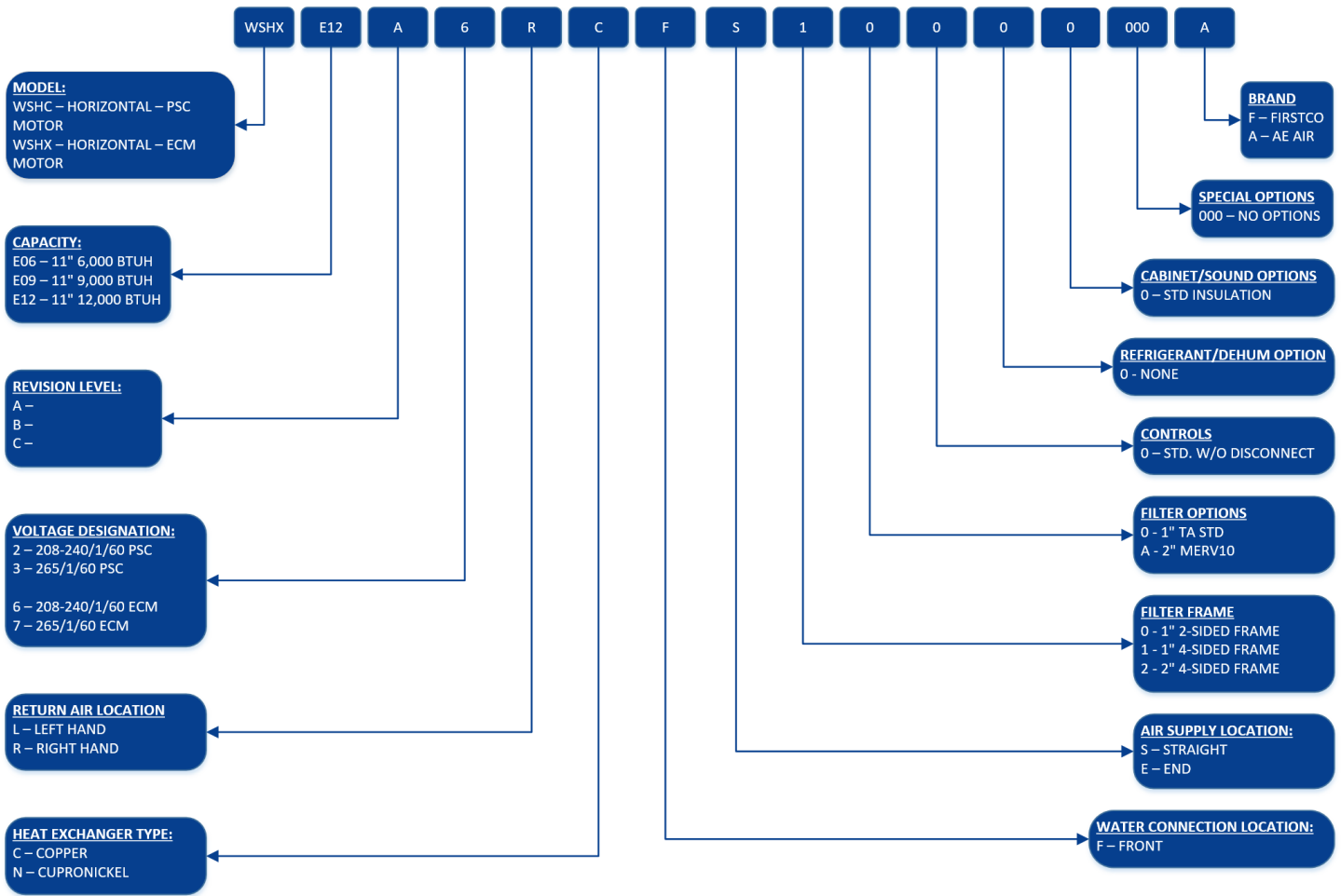

FIGURE 1 – Model Nomenclature

GENERAL INFORMATION

CAUTION

DO NOT use these units as a source of heating or cooling during the construction process. Mechanical components and filters can become clogged with dirt and debris, which can cause damage to the system.

The manufacture does not warrant equipment subjected to abuse.

WARNING

ELECTRIC SHOCK HAZARD

Before servicing equipment, ALWAYS turn off all power to the unit. There may be more than one disconnect switch. Electrical shock can cause injury or death.

Clear surrounding area of all tools, equipment, and debris before operating this unit.

These instructions are provided for the installation of the WSH(C,X) water source heat pump specifically. For any other related equipment, refer to the appropriate manufacturer's instructions.

CAUTION

This water source heat pump must never be operated under any circumstances without an air filter in place.

NOTE

Material in this shipment has been inspected at the factory and released to the transportation agency in good condition. When received, a visual inspection of all cartons should be made immediately. Any evidence of rough handling or apparent damage should be noted on the delivery receipt in the presence of the carrier's representative. If damage is found, a claim should be immediately filed against the carrier.

The WSH(C,X) water source heat pump is designed for indoor installation only. Installation of this equipment, wiring, ducts, and any related components must conform to current agency codes, state laws, and local codes. Such regulations take precedence over general instructions contained in this manual

CAUTION

Extreme caution must be taken that no internal damage will result from screws that are drilled into the cabinet.

INTRODUCTION

The Hydrotech WSH(C,X) series water to air heat pump provide the best combination of performance, efficiency and reliability in a compact form factor. The WSH(C,X) series comes standard with PSC blower motors. It is also available with ECM blower motors high efficiency and comfort. The heat pump features double compressor vibration isolation for quiet operation, easy to remove blower housing for quick service and easy service access from multiple sides.

All WSH(C,X) models are certified to AHRI ISO Standard 13256-1. The WSH(C,X) models are designed to operate with fluid temperatures between 50°F to 110°F in cooling mode and 50°F to 90°F in heating mode for continuous operation.

These installation instructions are intended as a general guide only, for use by an experienced, qualified contractor.

CAUTION

Do not use this water source heat pump during any phase of construction.

CAUTION

DO NOT use these units as a source of heating or cooling during the construction process. Mechanical components and filters can become clogged with dirt and debris, which can cause damage to the system.

The manufacture does not warrant equipment subjected to abuse.

STORAGE

Equipment should be stored in a clean dry, conditioned area with maximum temperatures up to 120°F [48.89°C] and minimum temperatures to 32°F [0°C]. Units should be stored upright and in an indoor environment. It is recommended to leave packaging on the unit until the installation is to begin.



WARNING



Do not stack more than **FOUR** units for storage purposes. Failure to follow these instructions may result in improper installation, adjustment, service or maintenance, property damage, personal injury or death.

DO NOT operate these units during the construction process. Mechanical components and filters could become clogged with dirt and debris, which can cause damage to the system.

The manufacturer does not warrant equipment subjected to abuse.

SHIPPING & PACKAGE LIST



NOTE



Material in this shipment has been inspected at the factory and released to the transportation agency in good condition. When received, a visual inspection of all cartons should be made immediately. Any evidence of rough handling or apparent damage should be noted on the delivery receipt in the presence of the carrier's representative. If damage is found, a claim should be immediately filed against the carrier.

SHIPPING INSTRUCTIONS

WSH(C,X) units must remain in the upright position as seen in **FIGURE 2 – Standard Packaging** throughout the shipping and handling process to maintain a proper level of oil in the compressor. DO NOT discard the shipping/hanger brackets



NOTE



Shrink-wrap is located around the unit for protection. Remove before installation.

NOTE:
SHRINK WRAP AROUND UNIT

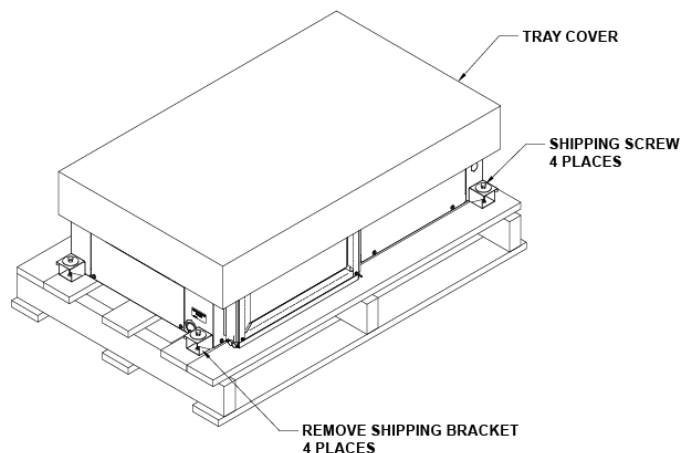

FIGURE 2 – Standard Packaging

PACKAGE LIST

The units will be shipped with the following items:

- 1- WSH(C,X) Horizontal unit:
 - A- Shipping/Hanger brackets
 - a. Screws
- 2- Literature package
 - A- IOM - Installation & Operations Manual

Check the unit for shipping damage; if found, immediately contact the last carrier.

UNIT INSPECTION CHECKLIST

Complete the inspection procedures below before preparing unit for installation:

- 1) Visually inspect unit for any shipping damage. Damage must be reported immediately to the shipping company to make a claim.
- 2) Ensure that the carrier makes proper notation of any shortages or damage on all copies of the freight bill and completes a common carrier inspection report.
- 3) Verify that unit nameplates on the data label match the sales order or bill of lading (including, unit configuration, size and voltage).
- 4) Immediately before installation, remove unit front panel and verify that all electrical connections are tight and that there are no loose wires.
- 5) Check to make sure that the refrigerant piping is free from any kinks and there is no interference between unit piping and sheet metal or electrical wires.
- 6) Check that the blower spins freely within the housing and that there are no obstructions between the wheel and housing. The wheel can sometimes come loose in shipping.
- 7) Ensure that the evaporator distributor tubes are not touching one in another and that they are over the drain pan.
- 8) Check the air-coil fins for any damage during shipping.
- 9) Ensure that the shipping screws are removed from the unit. Refer to [FIGURE 3 – Standard Packaging with Brackets – Front View](#) & [FIGURE 4 – Standard Packaging with Brackets – Back View](#) for more information.



NOTE



Check the unit nameplate for correct voltage with the plans before installing the equipment. Also, make sure all electrical ground connections are made in accordance with local code.

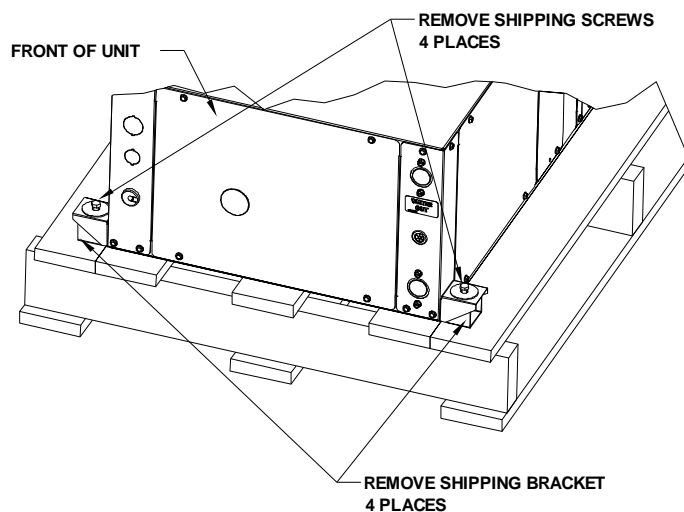

FIGURE 3 – Standard Packaging with Brackets – Front View

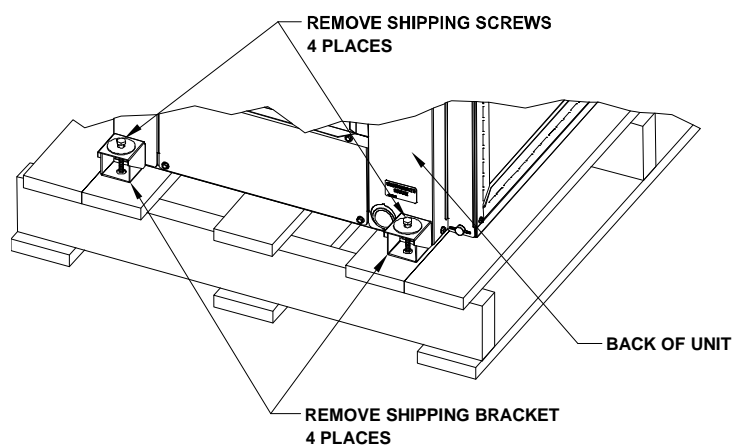

FIGURE 4 – Standard Packaging with Brackets – Back View

UNIT DIMENSIONAL DATA

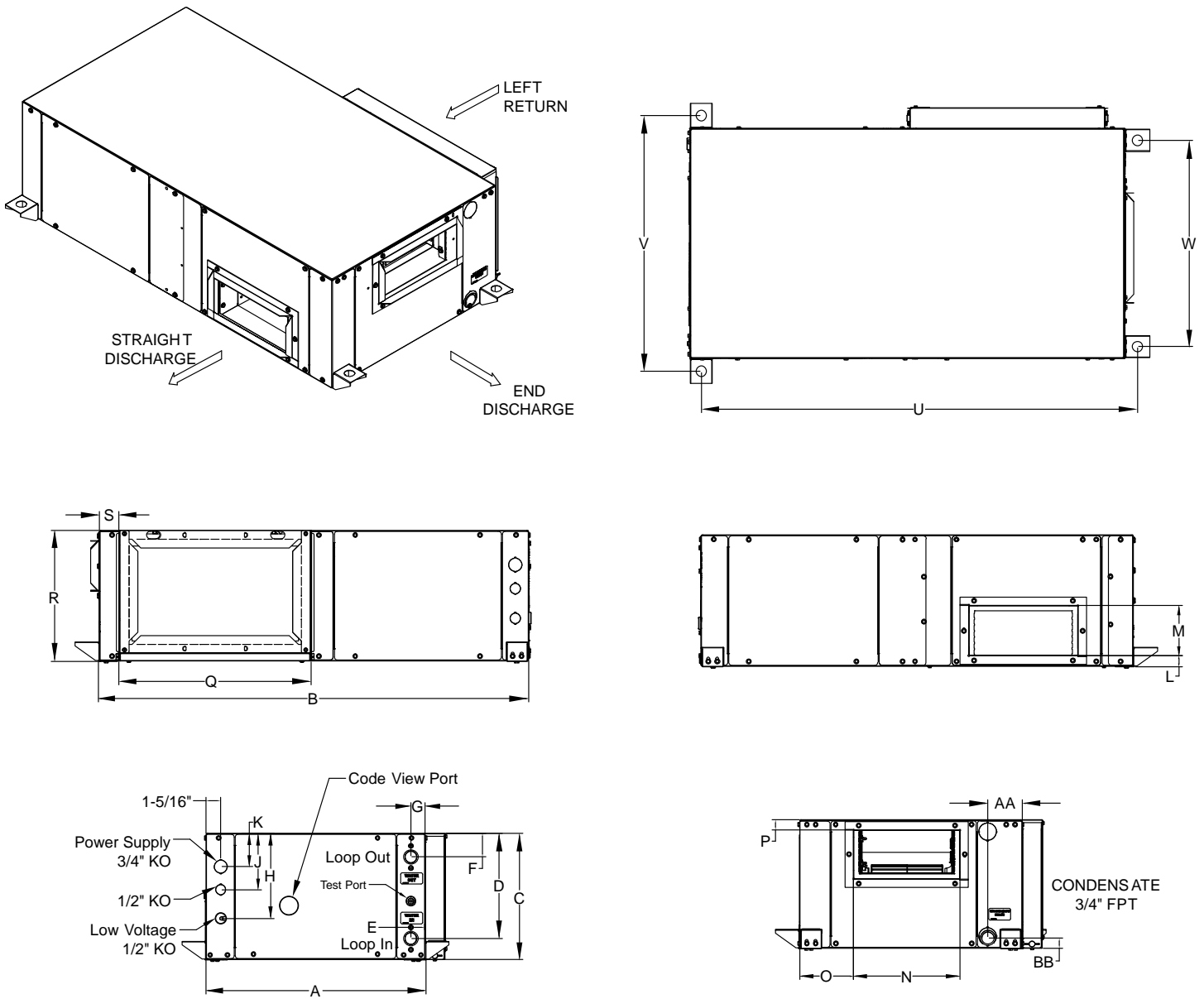

FIGURE 5 – Unit Dimensions



NOTE



Left return unit shown, Right return unit is mirrored.

UNIT DIMENSIONAL DATA CONTINUED

DIMENSIONAL DATA											
MODEL	OVERALL CABINET			CONNECTIONS				LOOP IN/OUT	ELECTRICAL KNOCKOUT		
	Width	Depth	Height	Loop In		Loop Out			Low Voltage		Line
	A	B	C	D	E	F	G	FPT	H ½"	J ½"	K ¾"
WSH(C,X)E06	19.0	36.0	11.0	9.2	1.3	2.1	1.3	3/4	7.4	4.4	2.9
WSH(C,X)E09	19.0	36.0	11.0	9.2	1.3	2.1	1.3	3/4	7.4	4.4	2.9
WSH(C,X)E12	19.0	36.0	11.0	9.2	1.3	2.1	1.3	3/4	7.4	4.4	2.9

Table 1 – Unit Dimensional Data

DIMENSIONAL DATA CONTINUED														
MODEL	DISCHARGE DUCT FLANGE					RETURN DUCT FLANGE				MOUTNING BRACKET CENTER DISTANCES			CONDENSATE ¾" FPT	
	L	M	N	O	P	Q	R	S	T	U	V	W	AA	BB
	WSH(C,X)E06	0.9	4.3	9.1	4.6	5.8	18.3	10.9	0.6	0.9	34.1	21.3	16.8	3
WSH(C,X)E09	0.9	4.3	9.1	4.6	5.8	18.3	10.9	0.6	0.9	34.1	21.3	16.8	3	0.9
WSH(C,X)E12	0.9	4.3	9.1	4.6	5.8	18.3	10.9	0.6	0.9	34.1	21.3	16.8	3	0.9

Table 2 – Unit Dimensional Data Continued

UNIT PHYSICAL DATA

PHYSICAL DATA			
WSHC MODELS	WSHCE06	WSHCE09	WSHCE12
UNIT INFORMATION			
Compressor Type (Qty)	Rotary (1)		
Factory Charge (R410A) lbs. [oz]	1.6 [26]	1.8 [26]	1.6 [26]
Motor (Qty)	1		
Fan Motor Type	PSC		
Fan Motor HP [kW]	1/8 [.09]	1/8 [.09]	1/5 [.15]
Blower (Qty)	1		
Blower Wheel Size (D x W) in. [cm]	5.25 x 6 [13.33 x 15.24]	5.25 x 6 [13.33 x 15.24]	6 x 5 [15.24 x 12.70]
Water Connection FPT (in)	3/4		
COAX Volume (US Gallons)	0.083	0.116	0.116
Condensate Connection FPT (in)	3/4		
Air Coil Dimension (H x W) in. [cm]	10 x 15 [25.4 x 38.1]		
Filter Size (H x W) in. [cm]	10 x 16 [25.4 x 40.6]		
Filter (Qty)	1		
Operating Weight lb. [kg]	108 [49]	110 [50]	110 [50]
Shipping Weight lb. [kg]	123 [56]	125 [57]	125 [57]
Notes: FPT = Female Pipe Thread			

Table 3 – Physical Data PSC

UNIT PHYSICAL DATA CONTINUED

PHYSICAL DATA			
WSHX MODELS	WSHXE06	WSHXE09	WSHXE12
UNIT INFORMATION			
Compressor Type (Qty)	Rotary (1)		
Factory Charge (R410A) lbs. [oz]	1.6 [26]	1.8 [26]	1.6 [26]
Motor (Qty)	1		
Fan Motor Type	ECM		
Fan Motor HP [kW]	1/4 [.18]	1/4 [.18]	1/4 [.18]
Blower (Qty)	1		
Blower Wheel Size (D x W) in. [cm]	5.25 x 6 [13.33 x 15.24]		
Water Connection FPT (in)	3/4		
COAX Volume (US Gallons)	0.083	0.116	0.116
Condensate Connection FPT (in)	3/4		
Air Coil Dimension (H x W) in. [cm]	10 x 15 [25.4 x 38.1]		
Filter Size (H x W) in. [cm]	10 x 16 [25.4 x 40.6]		
Filter (Qty)	1		
Operating Weight lb. [kg]	108 [49]	110 [50]	110 [50]
Shipping Weight lb. [kg]	123 [56]	125 [57]	125 [57]
Notes:			
FPT = Female Pipe Thread			

Table 4 – Physical Data ECM

ELECTRICAL DATA

ELECTRICAL DATA PSC									
MODEL NUMBER	VOLTAGE-PH-HZ	COMPRESSOR		BLOWER MOTOR		MIN. CIRCUIT AMPACITY	MAX. CIRCUIT PROTECTION	MIN. VOLTAGE	MAX. VOLTAGE
		RLA	LRA	FLA	HP				
WSHCE06	208/230-1-60	3	16	0.65	1/8	5	15	197	253
	265-1-60	2.3	13.2	0.6		4			
WSHCE09	208/230-1-60	4.3	25	0.65	1/8	7	15	197	253
	265-1-60	3.6	20	0.6		6			
WSHCE12	208/230-1-60	5.4	30	1.2	1/5	8	15	197	253
	265-1-60	4.5	24	1.1		7			

Table 5 – Electrical Data PSC

ELECTRICAL DATA ECM									
MODEL NUMBER	VOLTAGE-PH-HZ	COMPRESSOR		BLOWER MOTOR		MIN. CIRCUIT AMPACITY	MAX. CIRCUIT PROTECTION	MIN. VOLTAGE	MAX. VOLTAGE
		RLA	LRA	FLA	HP				
WSHXE06	208/230-1-60	3	16	2.3	1/4	7	15	197	253
	265-1-60	2.3	13.2			6			
WSHXE09	208/230-1-60	4.3	25	2.3	1/4	8	15	197	253
	265-1-60	3.6	20			7			
WSHXE12	208/230-1-60	5.4	30	2.3	1/4	10	15	197	253
	265-1-60	4.5	24			8			

Table 6 – Electrical Data ECM

INSTALLATION

REQUIREMENTS

Follow manufacturer's installation instructions, as well as local and municipal building codes.

INSTALLATION PRECAUTIONS



CAUTION



Always wear all appropriate personal protection Equipment when installing and servicing these units.



WARNING



Use multiple people when moving and installing these units. Failure to do so could result in injury or death.



CAUTION



Contact with metal edges and corners can result injury. Protective gloves should be worn when handling. Exercise caution when installing and servicing unit.

Observe the following precautions for typical installation:

- Always use proper tools and equipment.
- No wiring or any work should be attempted without first ensuring the unit is completely disconnected from the power source and locked out. Also, verify that a proper permanent and uninterrupted, ground connection exists prior to energizing power to the unit.
- Review unit nameplate and wiring diagram for proper voltage and control configurations. This information may vary from unit to unit.



CAUTION



When the unit is in operation components are rotating at high speeds and caution should be taken.



WARNING



When soldering and brazing, it is recommended to have a fire extinguisher readily available. When soldering and brazing close to valves or sensitive components, heat shields or wet rags are required to prevent damage to the valves or components.



NOTE



Insulation is installed in the unit to provide a barrier between varying atmospheres outside and within the unit. If insulation is damaged condensation can occur and can lead to corrosion, component failure, and possible property damage. Damaged insulation must be repaired prior to the operation of the unit. Insulation will lose its effectiveness and value when wet, torn, separated, and/or damaged.



CAUTION



When servicing this equipment, because of high pressures, make sure the reversing valve, expansion device, filter drier and other components are specifically designed for R-410A refrigerant.

ONLY USE service equipment specifically designated for use with R-410A.



WARNING



R-410A can become combustible if mixed with air at elevated temperature and/or pressure. Failure to follow this warning could result in property damage and personal injury or death.



CAUTION



Do not operate this equipment without an air filter.

INSTALLATION CONTINUED

UNIT CLEARANCE REQUIREMENTS

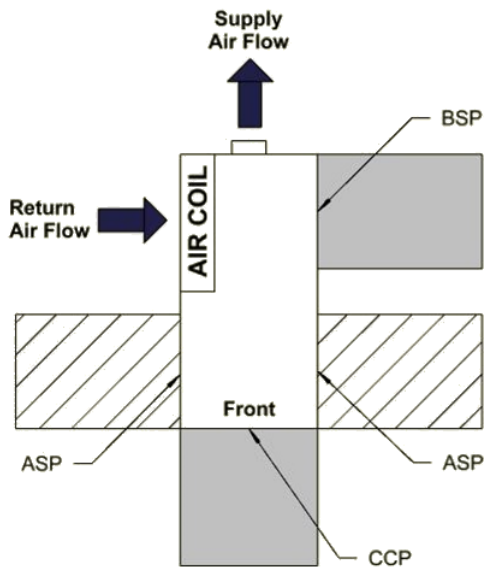

FIGURE 6 – Left Return Back Discharge

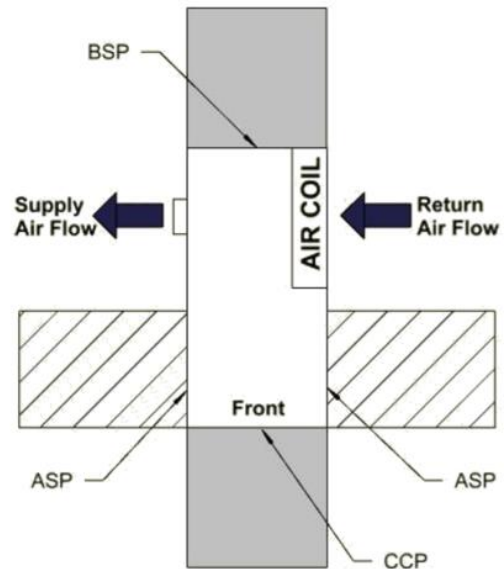

FIGURE 7 – Right Return Back Discharge

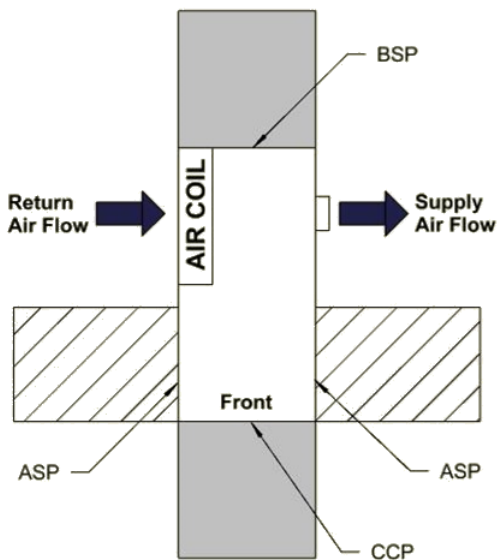

FIGURE 8 – Left Return Straight Discharge

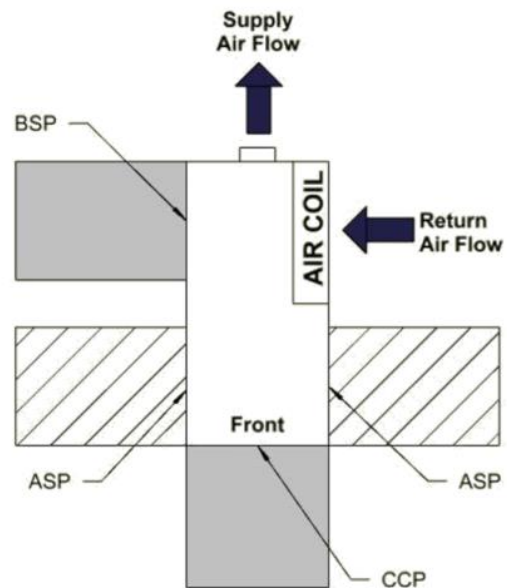

FIGURE 9 – Right Return Straight Discharge

Notes:

1. While clear access to all removable panels is not required, installer should take care to comply with all building codes and allow adequate clearance for future field service.
2. CCP and BSP requires 2' service access.
3. Blower service access is through back panel on straight discharge units or through panel opposite air coil on back discharge units.
4. ASP are removable panels that provide additional access to the units' interior. Clear access to ASP panels is not required and they are not to be used in place of the mandatory CCP and BSP panels.

■ = mandatory 2' service access

▨ = (optional) additional 2' service access

Legend:

CCP = Control/Compressor Access Panel
 BSP = Blower Service Panel
 ASP = Additional Service Panel (not required)

INSTALLATION CONTINUED

MOUNTING DETAILS

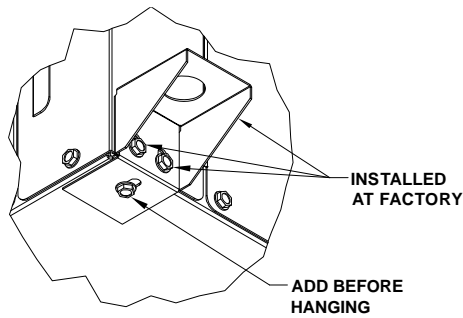

FIGURE 10 – Hanger Bracket

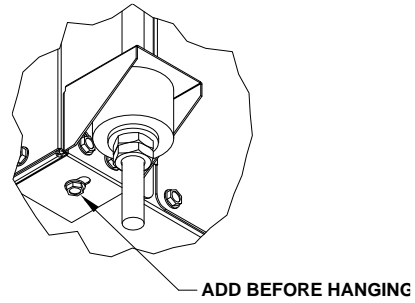

FIGURE 11 – Thread Hanging Rod

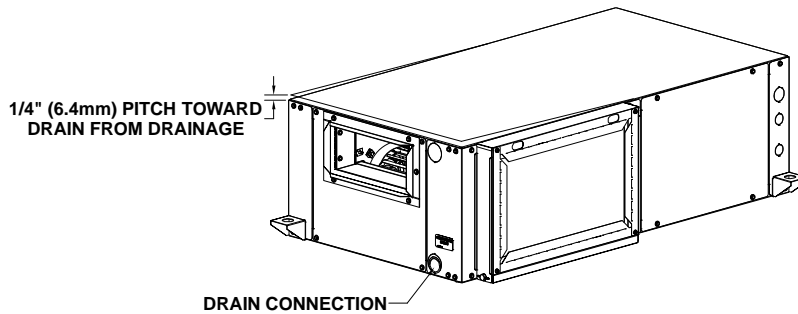

FIGURE 12 – Horizontal Unit Pitch



NOTE



It is important to ensure the unit is securely mounted and that the mounting structure is sufficient to support the operating weight of the equipment. Place and size all anchors to ensure a safe and durable installation.

These units are for indoor installation ONLY!

Do not locate unit in areas subject to freezing temperatures or where high humidity levels could cause cabinet condensation. WSHX units are available in right and left hand configurations. Locate the unit in an area that provides minimum clearance accesses as specified in Service Access section. Refer to [FIGURE 7 – Right Return Back Discharge](#), [FIGURE 7 – Right Return Back Discharge](#), [FIGURE 8 – Left Return Straight Discharge](#) & [FIGURE 9 – Right Return Straight Discharge](#)

FIGURE 8 – Left Return Straight Discharge & FIGURE 9 – Right Return Straight Discharge

Refer to [Table 1 – Unit Dimensional Data](#) and [Table 2 – Unit Dimensional Data Continued](#) for detailed information on unit dimensional sizes. Consider all additional clearances needed for water connections, electrical connections, duct connections and sufficient return airflow.

WSHX units are typically installed above a false ceiling or in a ceiling plenum. Each unit is suspended from the ceiling by four thread rods. The rods are attached to the unit corners by a hanger bracket through a rubber isolator. Refer to [FIGURE 10 – Hanger Bracket](#) & [FIGURE 11 – Thread Hanging Rod](#).

WSHX units have 4 hanger brackets partially attached at the factory, one at each corner. The hanger vibration kit is located at the blower opening area. The kit contains vibration isolation grommets, washers, screws and labels. Make sure to use the screws to secure all 4 hanger brackets to the bottom of the units as shown in [FIGURE 10 – Hanger Bracket](#). Insert the all-thread hanging rod through the bracket, vibration isolation grommet, washers and double nuts at the end of the rod as shown in [FIGURE 11 – Thread Hanging Rod](#). There should be a total of 4 rods. Ensure that the unit is approximately level and that the threaded rod extends past the nut. Pitch the unit toward the drain as shown in [FIGURE 12 – Horizontal Unit Pitch](#) to improve the condensate drainage.

INSTALLATION CONTINUED

TYPICAL MOUNTING INSTALLATION

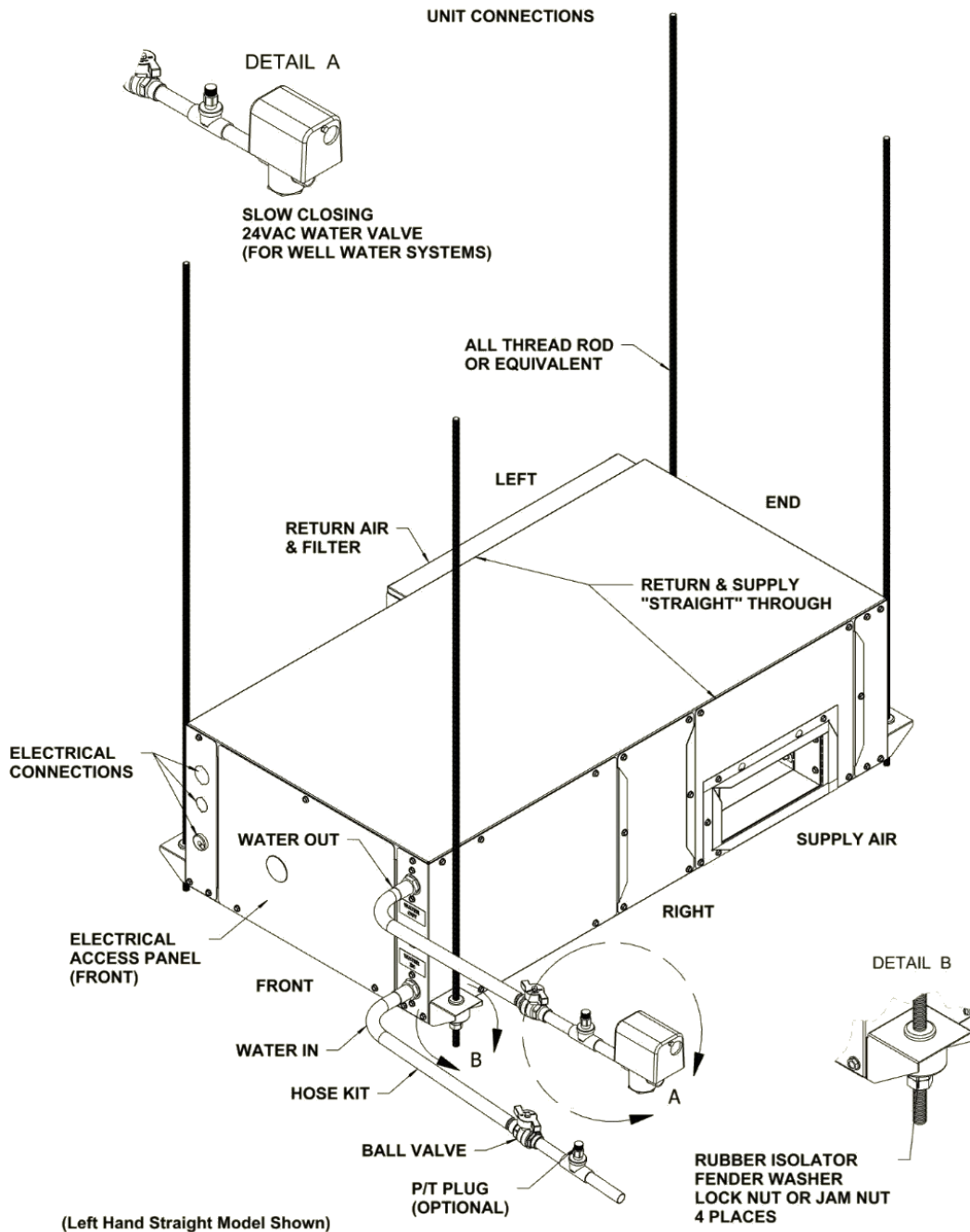

FIGURE 13 – Typical Mounting Installation

A horizontal unit should be positioned to allow for removal of the filters and access panels. Units should be located directly below a structural member, so that it is securely anchored. The filter needs to be slid out and sufficient space must be provided to allow this. Do not install the unit above any piping or electrical raceways. Avoid installing units directly above occupied spaces. This will minimize possible disruption to the occupants if maintenance or service is required as well as keeping a potential source of noise out of the area.

INSTALLATION CONTINUED

FIELD CONVERSION

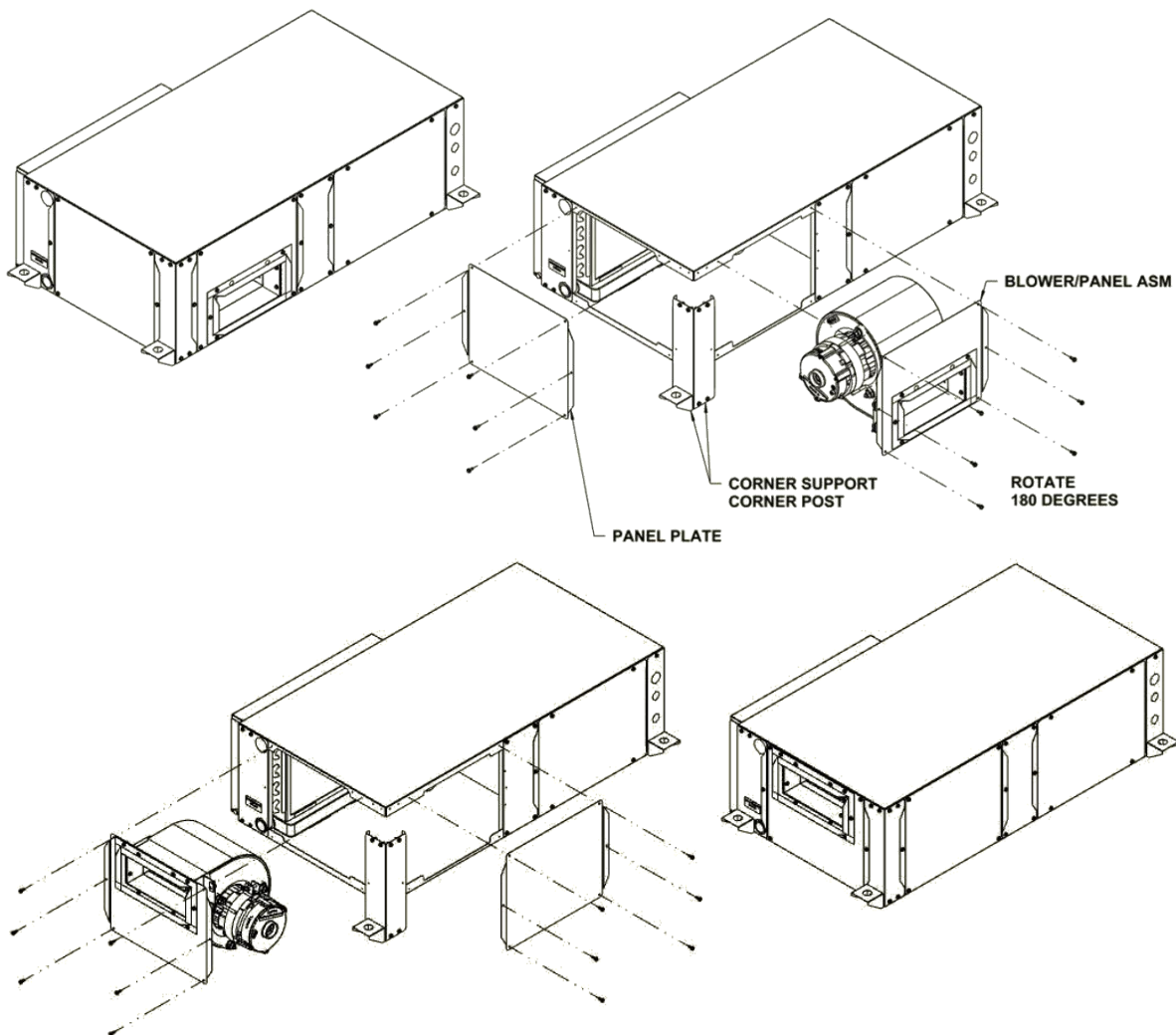

FIGURE 14 – Field Blower Conversion

WSH(C,X) units can be field converted between side (straight) and end discharge.



NOTE



Due to the necessary of refrigeration copper piping changes, it is not possible to field convert left return air to right return air models or vice versa.

Field conversion is best done on the ground before hanging.

1. Remove the six crews and the Panel Plate.
2. Remove the six screws holding the Blower Panel, remove the corner support corner post then remove the Blower Panel.
3. Rotate the Blower Panel 180° and slide in where Panel Plate used to be. Insert the corner support corner post and then screw in to secure the Blower Panel.
4. Place in the Panel Plate at the side and secure it with the remaining screws.

FIGURE 11 – Thread Hanging Rod shows straight to end discharge conversion. For end to straight discharge conversion, reverse the order of the pictures.

INSTALLATION CONTINUED

PIPING INSTALLATION

All piping must be adequately sized to meet the designed water flow as specified for the specific application, and must adhere to all applicable codes. Piping connections on the equipment are not necessarily indicative of the proper supply and return line sizes. Refer to the project drawings and specifications for sizing.

On units with plastic drain pans the drain connection must be made hand tight only.

Chilled water piping must be properly insulated to prevent condensation and potential property damage. It is also recommended that all piping be insulated to prevent freezing in unconditioned spaces.

CAUTION

Do not bend or kink supply lines or hoses. For all supply lines or hoses of 1-1/2" OD or greater, use proper sized fitting is recommended to prevent piping damage and potential restrictions in water flow.

NOTE

For all applications, 50°F minimum entering water temperature and rated water flow is required to prevent freezing. Antifreeze solution is required for any application with entering water below 50°F. Frozen water coils are not covered under warranty.

The WSH(C,X) water source heat pump are designed to operate with the entering liquid temperature between 50°F and 110°F. With the extended range option, the heat pump model can operate with entering liquid temperatures between 50-110°F. Below 50°F, antifreeze solution must be used to prevent freezing. Frozen water coils are not covered under warranty.

CONDENSATE DRAINAGE

Condensate drain lines must be properly installed with adequate slope away from unit to ensure proper drainage. A minimum trap of 1.5 inches must be installed to isolate the negative pressures of the drain pan from the drain line. Refer to [Figure 15 – Condensate Drain Layout](#) for schematic information on the condensate drain lines.

CAUTION

Check the condensate overflow sensor for proper operation and adjust if necessary. Final field adjustments ensures proper operation to avoid property damage.

CAUTION

On units with plastic drain pans, the drain connection must be made hand tight only.

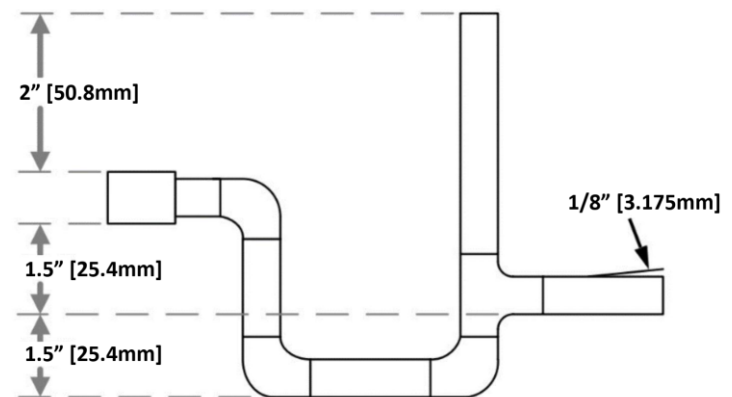

FIGURE 15 – Condensate Drain Layout

ELECTRICAL

HIGH VOLTAGE

WARNING

ELECTRIC SHOCK HAZARD

Disconnect all power supplies before servicing. Lock out/tag out to prevent accidental electrical shock. NOTE: There may be multiple power sources supplying the unit.

WARNING

Use copper conductors only. Install all parts and panels before operation of unit. Failure to follow these warnings can result in injury or death.

All wiring must comply with local and national code requirements. Units are provided with wiring diagrams and nameplate data to provide information required for necessary field wiring.

The WSH(C,X) water source heat pumps are provided with a class 2 transformer for 24VAC control circuits. Should any add-on accessory or component also have a class 2 transformer furnished, care must be taken to prevent interconnecting outputs of the two transformers by using a thermostat with isolating contacts.

WARNING

Connect ground wire to ground terminal marked "GND". Failure to do so can result in injury or death.

CAUTION

Any device that has been furnished by the factory for field installation must be wired in strict accordance with the associated wiring diagram. Failure to do so could damage components and void warranties.

208-230 VOLT OPERATION

All 208-230 Volt units are factory wired for 230 Volt operation. For 208 Volt operation, moving/changing/rewiring the line voltage tap on the 24 Volt control transformer is required. See note 3 on the wiring diagram for instruction.

LOW VOLTAGE

THERMOSTAT

A standard 24 VAC Heat Pump thermostat is required that will operate the reversing valve in the fooling mode.

Thermostat connections and their functions are below in **FIGURE 16 – Thermostat Connections** as follows:

- C – Transformer 24VAC Common
- O – Reversing Valve (energized in cooling)
- Y – Compressor Contactor
- R – Transformer 24VAC Hot
- G – Evaporator Blower

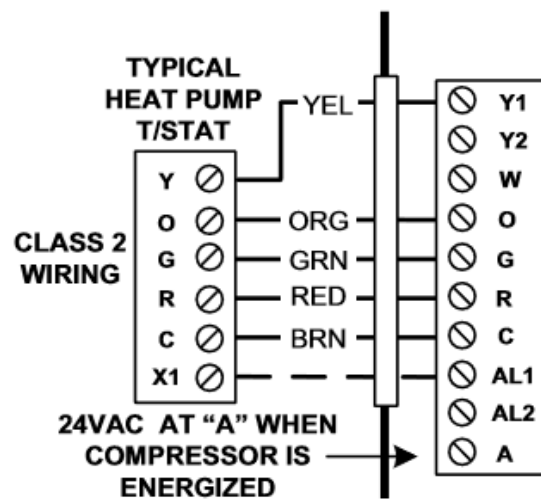

FIGURE 16 – Thermostat Connections

THERMOSTAT INSTALLATION

The Thermostat should be located on an interior wall in a larger room, away from supply duct draft. Position the thermostat back plate against the wall so that it appears level and so the thermostat wires protrude through the middle of the back plate mounting holes and drill holes with a 3/16" (5mm) bit. Install supplied anchors and secure plate to the wall. Thermostat wire must be 18 AWC wire.

APPLICATION

COOLING TOWER/BOILER APPLICATION

To ensure optimum cooling and heating performance, the cooling tower and boiler loop temperature should be maintained between 55-75°F in the heating mode and 60-95°F in the cooling mode. In the cooling mode, heat is rejected from the heat pump's refrigerant into the water loop. A cooling tower and/or boiler may be required to maintain proper water temperature within the water loop. In an open cooling tower, chemical water treatment is mandatory to ensure water is free of corrosive materials

In heating mode, heat is absorbed from the water loop into the heat pump's refrigerant. A boiler may be utilized to maintain the proper water temperature within the loop.

CAUTION

A boiler may be required in the water loop to maintain the loop water temperature between 55-75°F. Failure to maintain proper water loop temperatures could result in equipment failure and property damage, and void warranties.

A secondary heat exchanger (plate frame between the unit and the open cooling tower) may also be used. It is imperative that all air is eliminated from the closed loop side of the heat exchanger to prevent condenser fouling.

WARNING

Use copper conductors only. Install all parts and panels before operation of unit. Failure to follow these warnings can result in injury or death.

CAUTION

The manufacturer does **NOT WARRANT** equipment subjected to abuse. Dirt, piping chips or other foreign material can cause damage or failure to the water or to refrigerant heat exchanger.

EXTENDED RANGE OPERATION

Piping systems expected to utilize water temperature below 50°F require the extended range option, which includes closed cell installation on all piping surfaces to eliminate condensation. This application requires sufficient antifreeze solution to prevent the water loop against extreme temperature conditions and condenser coil

freezing. Frozen condenser coil are not covered under warranty. A boiler may be required to maintain the minimum water temperature within the loop.

WARNING

Connect ground wire to ground terminal marked "GND". Failure to do so can result in injury or death.

CAUTION

Any device that has been furnished by the factory for field installation must be wired in strict accordance with the associated wiring diagram. Failure to do so could damage components and void warranties.

CLOSED LOOPS

Failure to maintain proper water loop temperatures could result in equipment failure and property damage, and void warranties. Consult the factory when running entering water temperatures below 50°F as additional pipe insulation may be required to avoid excessive sweating inside the unit. For applications below 50°F it is imperative that the system be operated with antifreeze solution. When a secondary heat exchanger is used (i.e. plate to plate; closed loop system) it is imperative that all air is purged from the system to prevent condenser fouling.

CAUTION

The entire water loop must be completely cleaned and flushed of all debris prior to final connections and unit operation.

Valves should be adjusted to supply proper water flow rated for the unit.

Failure to do so will **VOID ALL FACTORY WARRANTY**.

APPLICATION CONTINUED

WATER WELL APPLICATION

REQUIREMENTS:

- 50° Minimum Entering Water Temperature
- Cupronickel Refrigerant Heat Exchanger

When a water well is used exclusively for supplying water to the heat pump, a cupronickel refrigerant heat exchanger is required and the well pump should operate only when the heat pump operate. A 24 Volt contactor can be wired to the ACC1 terminal on the Control Module which can be selected to be energize prior to or at compressor start-up, which would in turn energize the water pump to operate with the heat pump.

WELL WATER APPLICATION			
Potential Failure Mode	Water Chemistry Parameter	Copper	CuNi
Corrosion and Scaling	pH Level	7-9	7-9
	Hardness (Calcium or Magnesium Carbonate)	< 350 ppm	<350 ppm
	Langelier Saturation Index (LSI)	-0.5 to 0	-0.5 to 0
	Ryznar Stability Index (RSI)	6.2 – 6.8	6.2 – 6.8
	Hydrogen Sulfide	< 0.5 ppm	< 0.5 ppm
	Sulfates	< 125 ppm	< 125 ppm
	Chlorine	< 0.5 ppm	< 0.5 ppm
	Chlorides	< 20 ppm	< 150 ppm
	Carbon Dioxide	< 5 ppm	< 5 ppm
	Ammonia	< 2 ppm	< 2 ppm
	Ammonia Chloride, Nitrate, Hydroxide, Sulfate	< 0.5 ppm	< 0.5 ppm
Total Dissolved Solids (TDS)	< 1000 ppm	< 1500 ppm	
Iron Fouling	Iron, Iron Bacteria	< 0.2 ppm	< 0.2 ppm
	Iron Oxide	< 1 ppm	< 1 ppm
Erosion	Suspend Solids	< 10 ppm, < 600 Micron or 30 mesh filter size	< 10 ppm, < 600 Micron or 30 mesh filter size
	Design Water Velocity	3 GPM/TON	3 GPM/TON

Table 7 – Well Water Application Data

CAUTION

Minimum entering water temperature is 50°F. Failure to follow this warning could result in equipment failure and property damage.

The discharge water from the heat pump is not contaminated in any manner and can be disposed of in various way depending upon local codes.

CAUTION

Close loop and pond applications require specialized design knowledge. Do not attempt at these installations without the licensed installer the received specialized training.

CONTROLS

SEQUENCE OF OPERATION

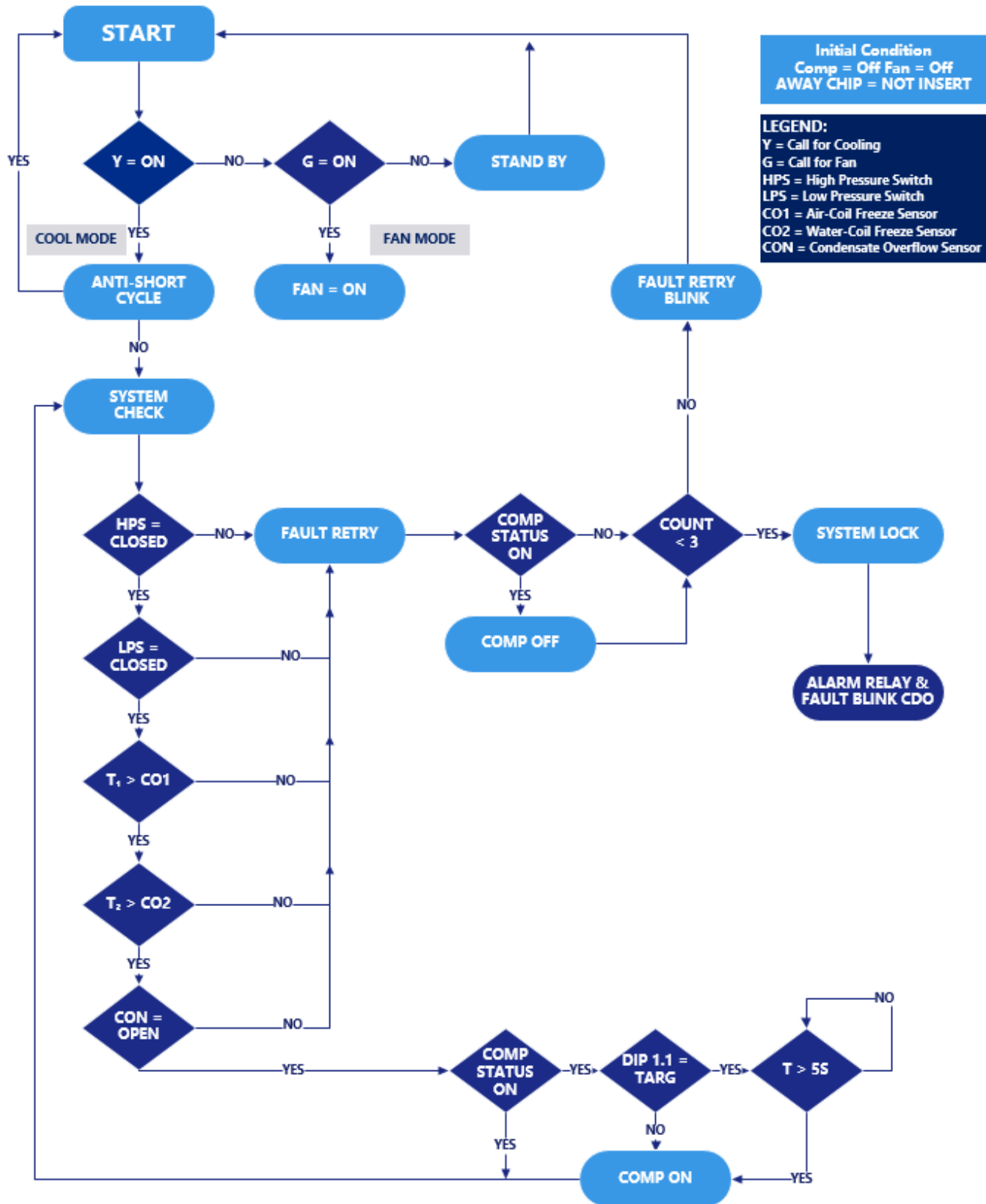

FIGURE 17 – Sequence of Operations

CONTROLS CONTINUED

WSCM CONTROL MODULE

CONTROL FEATURES

- Anti-short Cycle Protection
- Random Start
- High and low Pressure Cut-out
- Water Coil Low Temperature Cut-out
- Over/Under Voltage Protection
- Fault Retry
- Lockout with Soft and Hard Reset
- Condensate Overflow Sensor
- Diagnostic LED Display
- Test Mode
- Alarm Relay
- Accessory Relays
- Vacated Mode
- Extended Compressor Operating Monitoring

MOTOR SPEED OPERATION

An ECM or PSC blower can be driven directly from the WSCM control module. The control of the motor is based off the input signals of G, Y1, and O. The blower speed is automatically controlled via the WSCM module.

MOTOR SPEED OPERATION	
Unit Call	Fan Speed
G	G2
Y	G3
Y,O,G	G2, then G3 after 10min of run time

Table 8 – Motor Speed Operation ECM

MOTOR SPEED OPERATION	
Unit Call	Fan Speed
G	G2
Y	G2
Y,O,G	G2

Table 9 – Motor Speed Operation PSC

A secondary heat exchanger (plate frame between the unit and the open cooling tower) may also be used. It is imperative that all air is eliminated from the closed loop side of the heat exchanger to prevent condenser fouling.

FIELD CONTROLLABLE FUNCTIONS

TEST MODE

The unit can be placed into test mode by shorting the test pins on the WSCM module. Once the pins are shorted, the WSCM module will enter a test mode period in which all time delays are sped up 15 times. While in test mode the yellow LED2 will light up yellow. Faults stored in memory can be cleared by entering into test mode and exiting the test mode, or by a hard reset. Test mode can be exited by shorting the test pins for approximately 3 seconds.

NOTE

Test mode will be automatically exited after a 10 minute period.

NOTE

During test mode, the control will monitor to see if CO1 and CO2 freeze thermistors are present and correctly. The controls will indicate fault code 19 if CO1 or CO2 are open, or if there is a jumper connecting across the free sensors terminals.

VACATED PREMISES CONTROL

NOTE

Optional Vacated Premise Kit option must be installed to operate in this mode.

The vacated premises operation is designed for extended periods of un-occupancy when the occupant wants the heat pump to operate in cooling mode for a predetermined cycle time to help control indoor air conditions. See Dip 1.7 for time selection (1 or 2 hours).

Additionally, the mode will store all faults seen over 24 hours in memory. If the same fault occurs for 4 consecutive days, the unit will go into a hard lockout.

The control kit consist of a rocker switch, wiring and a programmed chip that is installed on the WSCM module by a licensed contractor.

CONTROLS CONTINUED

FIELD CONTROLLABLE FUNCTIONS

HOME SELECTION

If the switch is in the HOME position the heat pump will operate in its normal mode.

AWAY SELECTION

If the switch is in the AWAY position the heat pump and thermostat are set to "COOL" mode the heat pump will operate in accordance to the thermostat setting. Additionally, the heat pump will cycle on in cooling mode for 15 minute run times either 4 or 8 times per day depending on the Dip 1.7 selection. Thermostat still has priority and will cycle the unit as needed.



NOTE



If the LED display is flashing "Ay" the thermostat is not set in cooling mode.

BOILERLESS CONTROL

The system can operate in boilerless mode by switching Dip 1.5. If CO1 goes below the setting of Dip 1.6 the compressor will be de-energized and control goes into emergency heat mode staging on "W1". The compressor will be locked out for 60 minutes to prevent nuisance cycling.

The set point for boiler less changeover temperature can be adjusted by switching Dip 1.6.

WATER-COIL LOW TEMPERATURE CUT-OUT LIMIT

Jumpers JW1-CO1 provide field selection of the temperature limit settings for CO1.

Not Clipped = 30°F

Clipped = 10°F



CAUTION



For all applications below 50°F entering water temperature, anti-freeze solution is required. Failure to follow this warning could result in heat exchanger, equipment or property damage.

ALARM RELAY SETTING

Jumper 3 (JW3 Alarm) provides field selection of alarm relay terminal AL2 to be jumpered to 24VAC or to be dry. The alarm relay is activated during lockout mode.

Not Clipped = AL2 Connected to "R"

Clipped = AL2 dry contacts (No connection)

DEHUMIDIFICATION MODE

The system can operate in Dehumidification mode by switching Dip 1.4 on the WSCM module. In this mode, the unit will run continuously in fan speed G2 when Y,O, G calls are given to the board. Dehumidification mode will not run in heating mode.

WSCM SAFETY FEATURES

ANTI-SHORT CYCLE PROTECTION

The WSCM module incorporates a 5 minute anti-short cycle protection for the compressor.

RANDOM START

The WSCM module features a 5-80s random start upon receiving a call to operate.

FAULT RETRY

While in Fault Retry Mode the LED will display a code representing retry and the fault code. The unit will initiate the Anti-short cycle timer and try to restart after the delay. If 3 consecutive faults occur without satisfying the thermostat the unit will go into hard lockout. The last fault causing the lockout will be stored in memory and displayed on the two digit LED display.

WATER-COIL LOW TEMPERATURE CUT-OUT (CO1)

The control module will recognize a CO1 fault during a compressor run cycle if:

- Thermistor temperature is below the selected set point limit.
- The thermistor temperature is rising at a rate less than 2°F per 30s time period. The CO1 input is bypassed for the first 120s of a compressor run cycle. On the second and third retry CO1 is bypassed for the initial 90s and 60s of run-time respectively.

AIR COIL LOW TEMPERATURE CUT-OUT (CO2)

The control module will recognize a CO2 fault during a compressor run cycle if:

- Thermistor temperature is below the selected set point limit.
- The thermistor temperature is rising at a rate less than 2°F per 30s time period. The CO2 input is bypassed for the first 120s of a compressor run cycle.

CONTROLS CONTINUED

WSCM SAFETY FEATURES

CONDENSATE OVERFLOW SENSOR

The condensate overflow sensor must sense overflow levels for 30 continuous second to initiate a COF fault. The condensate overflow sensor will be monitored during the compressor run cycle.

LOW PRESSURE

The low pressure switch must be open and remain open for 30 continuous seconds during the “on” cycle to be recognized as a low pressure fault. The low pressure switch input is bypassed for the initial 120s of compressor run-time.

HIGH PRESSURE

If the high-pressure switch opens at any time, the compressor relay is de-energized immediately.

LOCKOUT MODE

While in Lockout Mode the LED Display will display a code representing the lockout fault code. During this lockout the compressor relay is not energized and the alarm relay is activated.

The lockout mode can be cleared by either going into test mode or a hard reset via the power disconnect

Caution: Do not restart units in lockout mode without inspection and correction of the fault condition. Failure to do so many result in equipment damage.

EXTENDED COMPRESSOR OPERATION MONITORING

If the compressor relay has been energized for four continuous hours, control module will automatically turn off the compressor relay and the compressor will enter anti-short cycle delay before restarting. During this off period, all appropriate safety will be monitored and if the compressor demand is present, the control module will energize the compressor relay.

OVER/UNDER VOLTAGE SHUTDOWN

Should an Over/Under Voltage Condition be detected the control module will shut down. Over/Under Voltage faults cause a soft lockout and the unit will return to normal operation once normal voltage has been restored. The nominal voltage run is 18.5VAC to 31VAC. If the WSCM module is in Over/Under Voltage fault for 15 minutes, the alarm relay will activate.

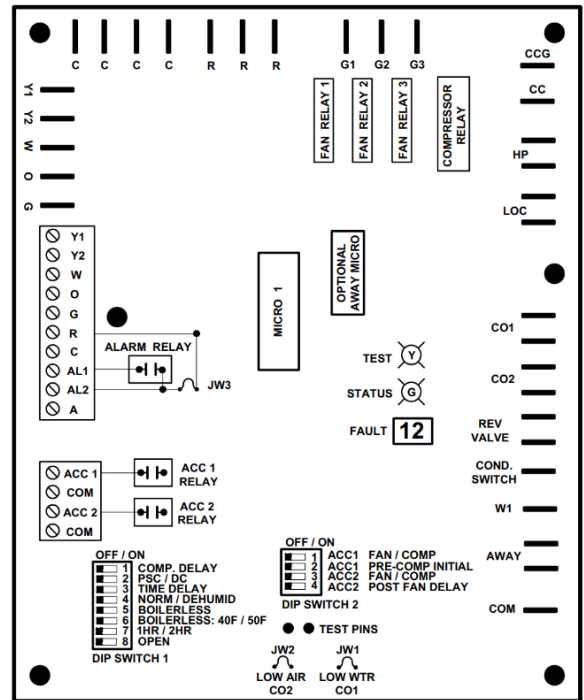

FIGURE 18 – Control Board Layout

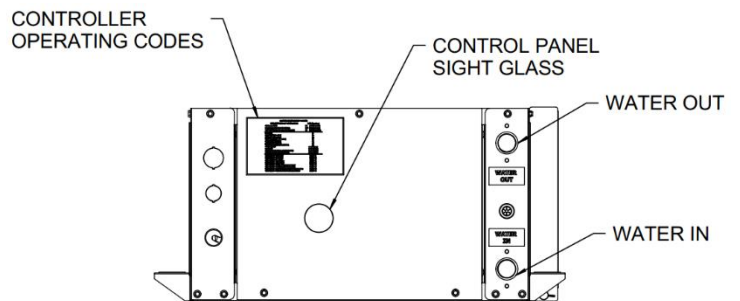

FIGURE 19 – Sight Glass Location

CONTROLS CONTINUED

WSCM SAFETY FEATURES

CONTROL BOARD LAYOUT LEGEND		
CONNECTION	INPUT OR OUTPUT	DESCRIPTION
R	--	24 VAC
C	--	24 VAC (Grounded Common)
Y1	I	Input Call for Compressor
W	I	Input Call for Heating or Emergency Heat
O	I	Input Call for Reversing Valve in Cooling
G	I	Input Call for Fan Operation
AL1	O	Connect to Thermostat Fault Light – 24VAC or Dry Contact Alarm
AL2	O	Alarm Relay 24VAC or Dry Contact
A	O	Output for Water Solenoid Valve – Paralleled with Compressor Contactor
ACC1	O	ACC1 Output for Accessory Relay 1 – 24VAC between ACC1 and COM
ACC2	O	ACC2 Output for Accessory Relay 2 – 24VAC between ACC2 and COM
G1	O	Connection for Fan Relay – Low Speed Operation
G2	O	Connection for Fan Relay – Medium Speed Operation
G3	O	Connection for Fan Relay – Large Speed Operation
CC	O	Connection for Compressor Contactor
CCG	O	Compressor Contactor Common Connections
HP	I	High Pressure Switch Input Terminals
LOC	I	Low Pressure Switch Input Terminals
CO1	I	Water Coil Low Temperature Thermistor Output
CO2	I	Air Coil Low Temperature Thermistor Output
RV	O	Reversing Valve Output Terminals – Direct Connect from “O”
COND_SW	I	Condensate Overflow Input Terminal
W1	O	Output Terminal for Electric Heat
COM	--	Grounded Common

Table 10 – Control Board Layout Legend

CONTROLLER OPERATION CODES	
DESCRIPTION OF OPERATION	LED READOUT
Normal Mode	ON (Green Light)
Controller Non Functional	OFF (Green Light)
Test Mode (pins shorted momentarily)	ON (Yellow Light)
DESCRIPTION OF OPERATION	CODE
Standby	ST
Fan Only(G active)	Fo
Cool (Y1 & O active)	Co
Heat 1st Stage (Y1 active)	H1
Accessory Relay 1	A1
Accessory Relay 2	A2
Vacated Premises Control	Ay
Fault Retry	rE & CODE #
Lockout	Lo & CODE #
Over/Under Voltage Shutdown	Ou & CODE #
Temperature Sensor Error	SE & CODE #
DESCRIPTION OF OPERATION	CODE
Test Mode – No Fault	11
Test Mode – HP Fault	12
Test Mode – LP Fault	13
Test Mode – CO1 Fault	14
Test Mode – CO2 Fault	15
Test Mode – Cond. Overflow Fault	16
Test Mode – Over/Under Shutdown	17
Test Mode – Swapped CO1/CO2 Thermistors	18

Table 11 – Control Operating Codes

CONTROLS CONTINUED

WSCM SAFETY FEATURES

WSCM DIP SWITCH FUNCTIONS			
FUNCTION		OFF	ON
DIP SWITCH 1			
1.1	Compressor Delay	No Delay	5s Delay
1.2	Motor Type	PSC Motor	ECM Motor
1.3	Blower Time Delay	None	45s
1.4	Dehumidification	None	Dehum
1.5	Boilerless	Off	On
1.6	Boilerless Setpoint	40°F	50°F
1.7	Vacated Premises	1hr	2hr
DIP SWITCH 2			
2.1	Accessory Relay Control	With Fan	With Comp
2.2	Compressor Delay	None	60s
2.3	Accessory Relay 2 Control	With Fan	With Comp
2.4	Fan Delay	None	30s

Table 12 – WSCM DIP Switch Functions

CONTROL BOX DETAIL

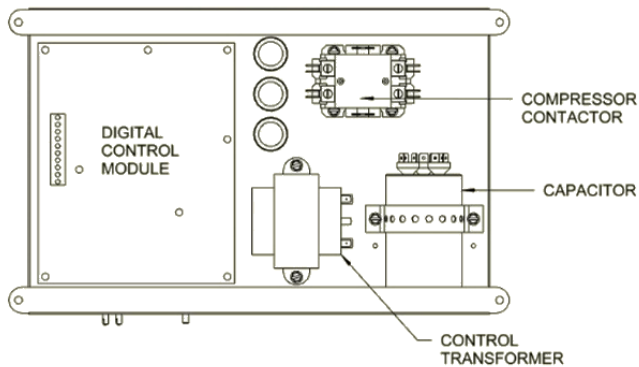

FIGURE 20 – Control Box Layout

ASSEMBLY

Once box is removed completely, line up the control panel back in place of the unit and tighten screws on the base plate and on the front panel. Plug back any harnesses previously removed.

REMOVAL

- 1) Ensure that all electrical power is removed from the unit and that the local disconnect is locked out.
- 2) Remove the screws on the front electrical panel with a ¼" hex head driver.
- 3) Remove the electrical front panel and access the electrical box
- 4) Disconnect the electrical harnesses located on the top of the ebox.
- 5) Remove the two ¼" hex header screws holding the electrical box in place on the bottom and side.

Remove electrical box from unit.

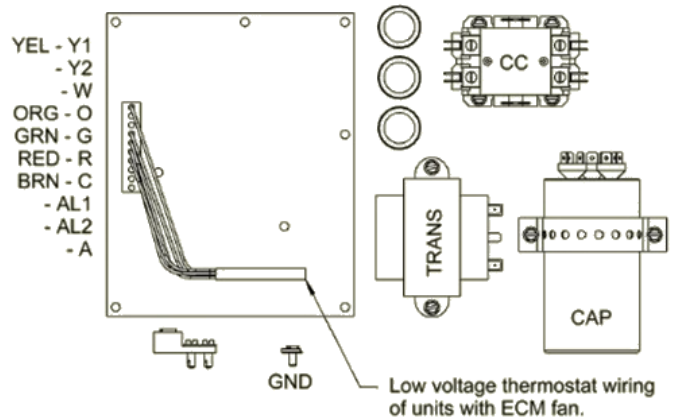

FIGURE 21 – Control Voltage Layout

⚠ WARNING ⚠

⚡ ELECTRIC SHOCK HAZARD ⚡

Disconnect all power supplies before servicing. Lock out/tag out to prevent accidental electrical shock.

i NOTE i

There may be multiple power sources supplying the unit.

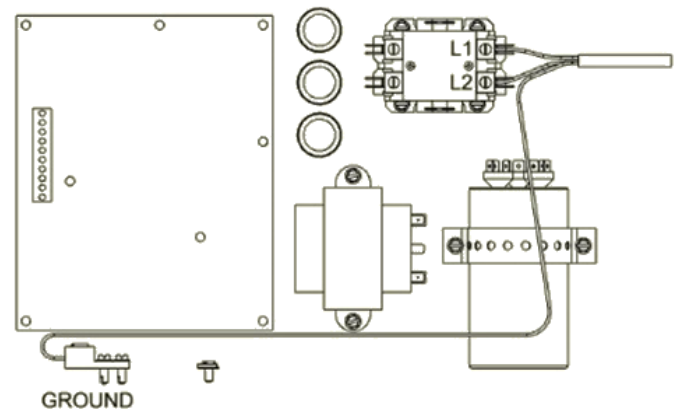

FIGURE 22 – Single Phase Line Voltage Field Wiring

BLOWER REMOVAL

REMOVAL

1. Ensure all electrical power is removed from the unit.
2. Remove screws from service side panel.
3. Disconnect blower harness.
4. Loosed and remove screws holding blower assembly.
5. Pull blower assembly backwards and out of unit.

ASSEMBLY

1. Reverse procedure to re-install blower assembly.

UNIT SEEN IS RH COIL, AIR RETURN BACK

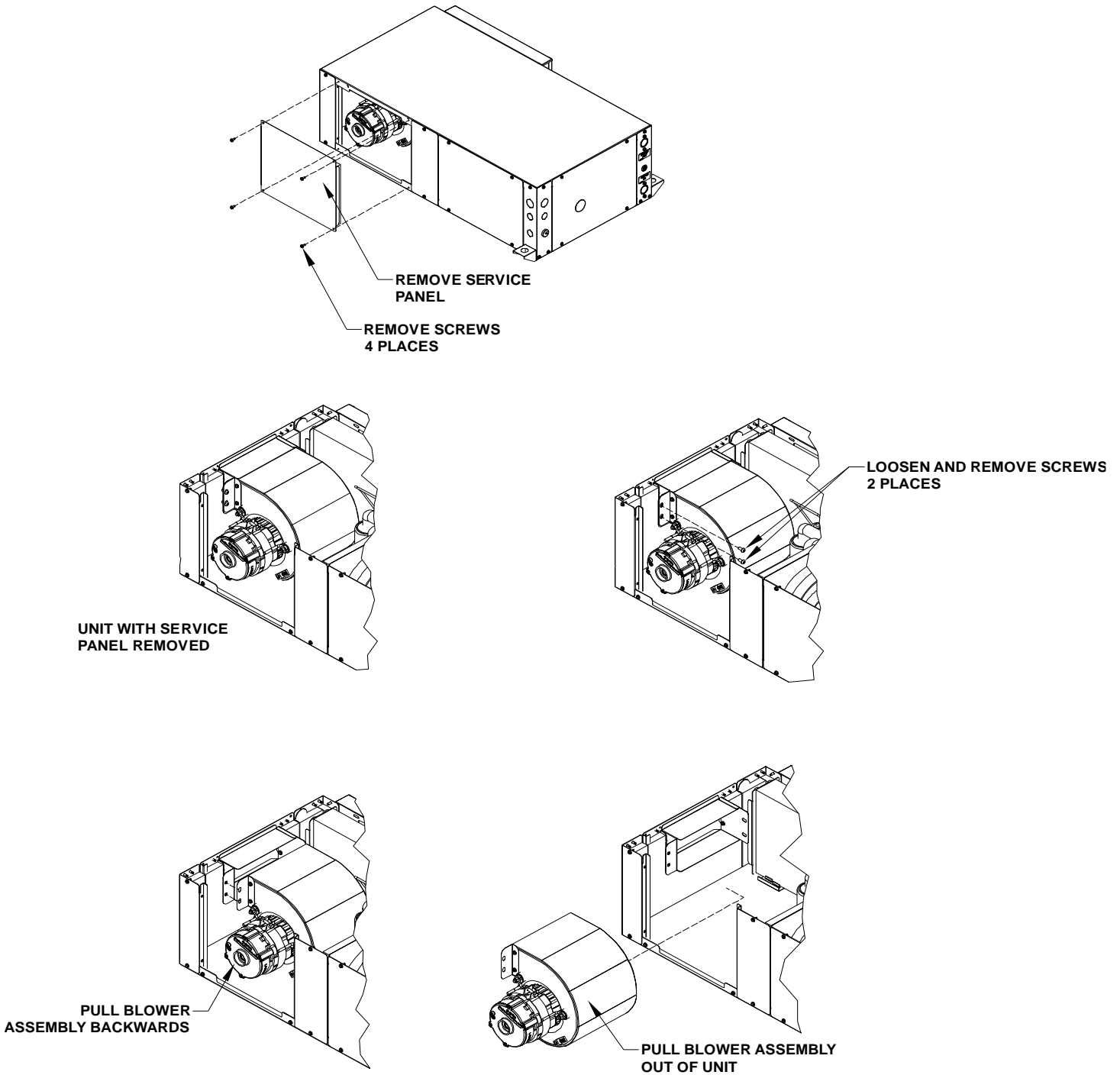

FIGURE 23 – Blower Removal Detail

PERFORMANCE DATA

BLOWER DATA

BLOWER DATA ECM															
BLOWER DATA													FACTORY BLOWER SETTINGS		
MODEL NUMBER	FAN SPEED	RATED AIRFLOW	CFM VS. STATIC PRESSURE (in. w.g.)										COOLING		HEATING
			0.1	0.2	0.3	0.4	0.5	0.6	0.7	0.8	0.9	1.0	1-10 MIN	10+ MIN	
WSHXE06	T3	300	390	370	340	300	250	230	210	190					
	T2		310	300	280	270	230	210	190				X	X	
	T1		210	190	170	150							X		
WSHXE09	T3	330	420	390	360	320	280	260	230						
	T2		390	370	340	300	250	230	210				X	X	
	T1		310	300	280	270	230	210				X			
WSHXE12	T3	400	450	420	390	360	320	280							
	T2		390	370	340	300	280						X	X	
	T1		310	300	280	270						X			

Airflow data shown is with a dry coil at 70°F DB EAT and with standard 1" filter.

Table 13 – WSHX Blower Data

BLOWER DATA PSC														
BLOWER DATA													FACTORY BLOWER SETTINGS	
MODEL NUMBER	FAN SPEED	RATED AIRFLOW	CFM VS. STATIC PRESSURE (in. w.g.)										COOLING	HEATING
			0.1	0.2	0.3	0.4	0.5	0.6	0.7	0.8	0.9	1.0		
WSHCE06	HIGH	300	330	310	260	230	190							
	MEDIUM		320	290	250	220	180						X	X
	LOW		310	280	240	210	170							
WSHCE09	HIGH	330	330	310	260	230	190							
	MEDIUM		320	290	250	220	180						X	X
	LOW		310	280	240	210	170							
WSHCE12	HIGH	450	480	450	420	390	360	330						
	MEDIUM		430	400	370	340	310						X	X
	LOW		370	340	320	300								

Airflow data shown is with a dry coil at 70°F DB EAT and with standard 1" filter.

Table 14 – WSHC Blower Data

PERFORMANCE DATA CONTINUED

PRESSURE & TEMPERATURE DATA

WSH(C,X)E06 PRESSURE & TEMPERATURE DATA									
Entering Water Temp	Water Flow Rate	COOLING				HEATING			
		Suction Pressure	Discharge Pressure	Air Temp Drop	Water Temp Rise	Suction Pressure	Discharge Pressure	Air Temp Drop	Water Temp Rise
°F	GPM	psig	psig	°F	°F	psig	psig	°F	°F
50	1	135-145	213-223	19-25	17-21	101-111	285-295	19-25	5-9
	1.5	133-143	208-218	19-25	12-16	103-113	287-297	19-25	4-8
	2	133-143	203-213	20-26	8-12	105-115	288-298	20-26	4-8
70	1	139-149	285-295	18-24	16-20	143-153	317-327	25-31	8-12
	1.5	138-148	272-282	19-25	10-14	146-156	320-330	26-32	7-11
	2	138-148	268-278	19-25	7-11	149-159	321-331	26-32	7-11
90	1	139-149	388-398	16-22	16-20	193-203	355-365	32-38	11-15
	1.5	143-153	362-372	18-24	10-14	198-208	359-369	33-39	8-12
	2	143-153	358-368	18-24	7-11	203-213	363-373	33-39	8-12
110	1	150-160	496-506	15-21	15-19	Operation Not Recommended			
	1.5	150-160	474-484	15-21	10-14				
	2	150-160	469-479	16-22	7-11				

Table 15 – WSH(C,X)E06 Pressure & Temperature Data

WSH(C,X)E09 PRESSURE & TEMPERATURE DATA									
Entering Water Temp	Water Flow Rate	COOLING				HEATING			
		Suction Pressure	Discharge Pressure	Air Temp Drop	Water Temp Rise	Suction Pressure	Discharge Pressure	Air Temp Drop	Water Temp Rise
°F	GPM	psig	psig	°F	°F	psig	psig	°F	°F
50	1.5	120-130	202-212	25-31	16-20	91-101	348-358	24-30	6-10
	2	117-127	191-201	25-31	12-16	95-105	352-362	25-31	4-8
	2.5	116-126	184-194	26-32	10-14	97-107	354-364	25-31	3-7
70	1.5	127-137	262-272	22-28	14-18	130-140	385-395	32-38	9-13
	2	126-136	251-261	22-28	10-14	136-146	392-402	33-39	6-10
	2.5	125-135	244-254	22-28	8-12	140-150	396-406	34-40	5-9
90	1.5	132-142	342-352	20-26	13-17	177-187	435-445	41-47	12-16
	2	132-142	329-339	20-26	9-13	184-194	443-453	42-48	10-14
	2.5	131-141	322-332	20-26	7-11	192-202	454-464	44-50	7-11
110	1.5	138-148	441-451	18-24	12-16	Operation Not Recommended			
	2	137-147	428-438	19-25	9-13				
	2.5	137-147	421-431	19-25	7-11				

Table 16 – WSH(C,X)E09 Pressure & Temperature Data

PERFORMANCE DATA CONTINUED

PRESSURE & TEMPERATURE DATA

WSH(C,X)E12 PRESSURE & TEMPERATURE DATA									
Entering Water Temp	Water Flow Rate	COOLING				HEATING			
		Suction Pressure	Discharge Pressure	Air Temp Drop	Water Temp Rise	Suction Pressure	Discharge Pressure	Air Temp Drop	Water Temp Rise
°F	GPM	psig	psig	°F	°F	psig	psig	°F	°F
50	1.5	122-132	222-232	22-28	21-25	98-108	329-339	22-28	10-14
	2.25	121-131	202-212	22-28	13-17	106-116	338-348	23-29	7-11
	3	120-130	193-203	23-29	9-13	110-120	343-353	24-30	5-9
70	1.5	126-136	293-303	21-27	20-24	136-146	374-384	29-35	14-18
	2.25	125-135	272-282	21-27	13-17	140-150	370-380	29-35	9-13
	3	125-135	263-273	21-27	9-13	155-165	398-408	32-38	7-11
90	1.5	131-141	380-390	20-26	19-23	182-192	430-440	36-42	18-22
	2.25	130-140	358-368	20-26	12-16	200-210	452-462	39-45	12-16
	3	130-140	350-360	20-26	9-13	210-220	465-475	40-46	9-13
110	1.5	137-147	487-497	18-24	18-22	Operation Not Recommended			
	2.25	136-146	466-476	19-25	12-16				
	3	136-146	458-468	19-25	8-12				

Table 17 – WSH(C,X)E12 Pressure & Temperature Data

WATER PRESSURE DROP DATA

WATER PRESSURE DROP DATA						
WSH(C,X)E06	GPM	1	1.25	1.5	1.75	2
	PSI	0.1	0.4	0.8	1.2	1.6
WSH(C,X)E09	GPM	1	1.5	2	2.5	3
	PSI	0.6	1.0	1.6	2.3	3.0
WSH(C,X)E12	GPM	2	2.5	3	3.5	4
	PSI	1.3	1.9	2.0	3.3	3.8
	GPM – Flow Rate PSI – Pressure Drop					

Table 18 – Water Pressure Drop Data

WIRING DIAGRAMS

WSHXE06/12-WIRING DIAGRAM (208-230V)

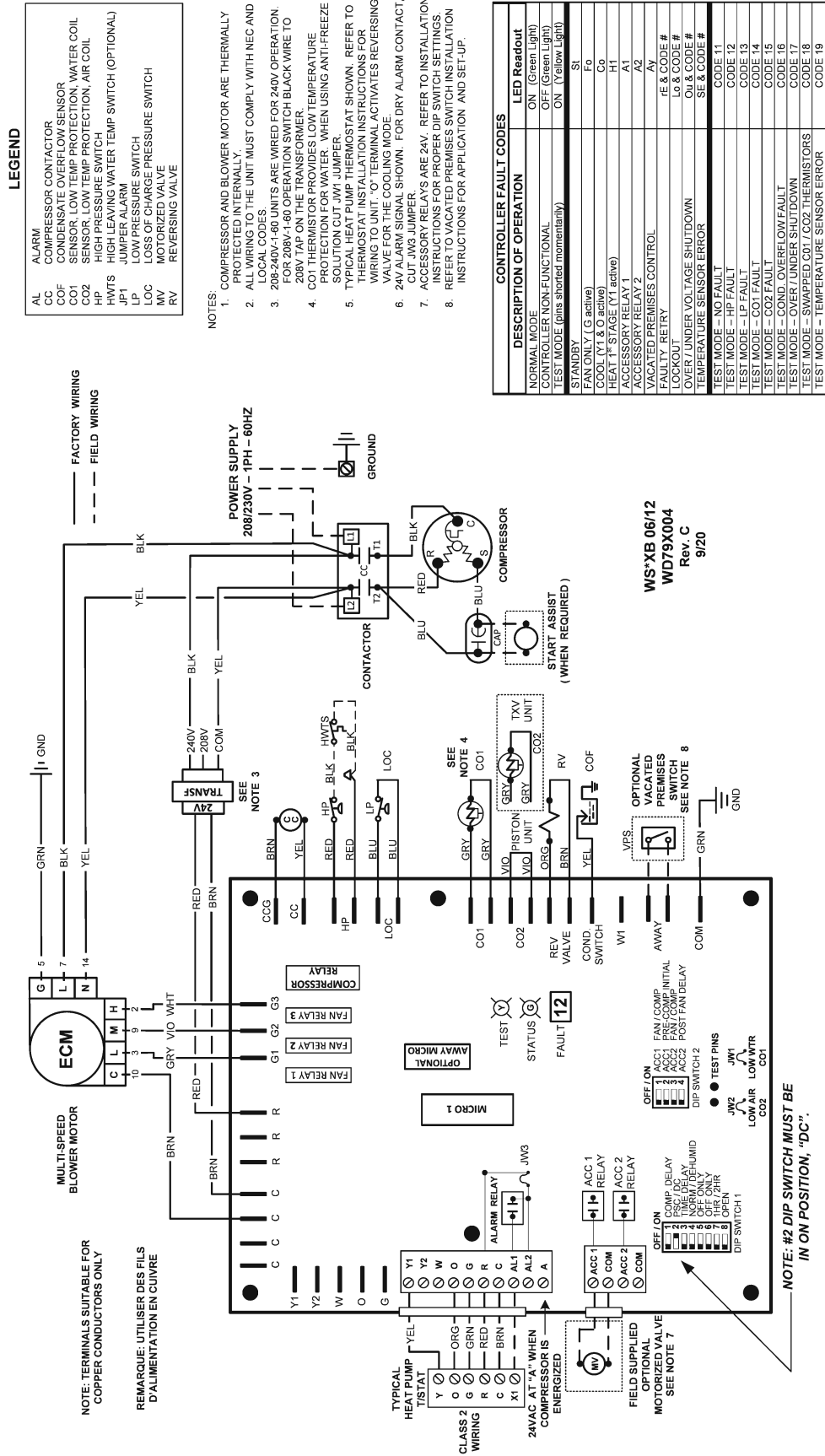

FIGURE 154 – WSHXE06/12(208-230V) Wiring Diagram

WIRING DIAGRAMS

WSHXE06/12-WIRING DIAGRAM (265V)

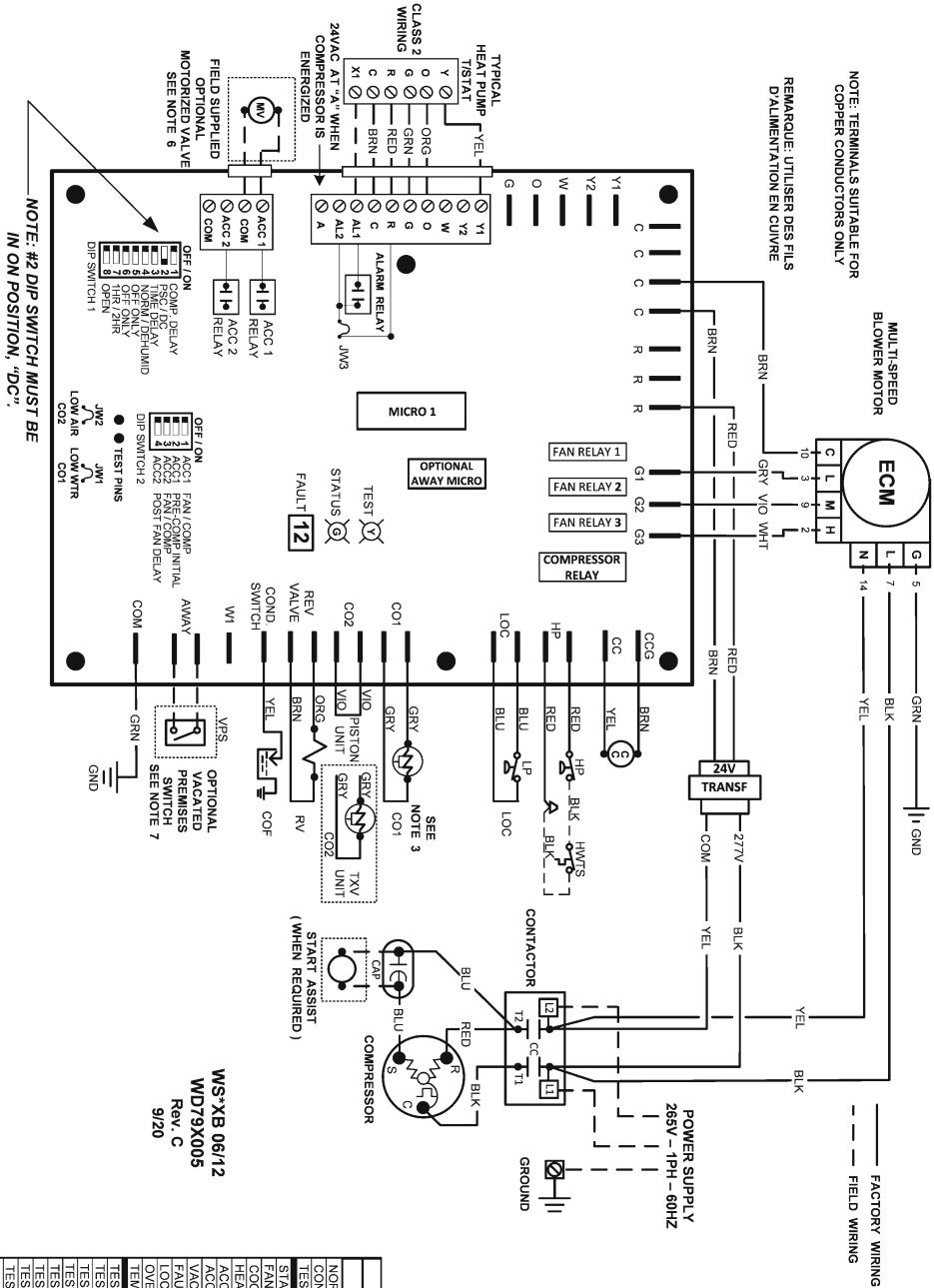

FIGURE 25 – WSHXE06/12(265V)* Wiring Diagram

CONTROLLER FAULT CODES	
DESCRIPTION OF OPERATION	LED Readout
NORMAL MODE	ON (Green Light)
CONTROLLER NON-FUNCTIONAL	OFF (Green Light)
TEST MODE (flashes momentarily)	ON (Yellow Light)
STANDBY	St
FAN ONLY (G active)	Fo
COOL (Y1 & O active)	Co
HEAT 1 st STAGE (Y1 active)	H1
ACCESSORY RELAY 1	A1
ACCESSORY RELAY 2	A2
VACATED PREMISES CONTROL	AV
FAULTY RETRY	L6 & CODE #
LOCKOUT	SL & CODE #
OVER/UNDER VOLTAGE SHUTDOWN	SE & CODE #
TEMPERATURE SENSOR ERROR	
TEST MODE - NO FAULT	CODE 11
TEST MODE - HP FAULT	CODE 12
TEST MODE - LP FAULT	CODE 13
TEST MODE - CO1 FAULT	CODE 14
TEST MODE - CO2 FAULT	CODE 15
TEST MODE - COND OVERFLOW FAULT	CODE 16
TEST MODE - OVER/UNDER SHUTDOWN	CODE 17
TEST MODE - SWAPPED CO1/CO2 THERMISTORS	CODE 18
TEST MODE - TEMPERATURE SENSOR ERROR	CODE 19

WIRING DIAGRAMS

WSHCE06/09-WIRING DIAGRAM (208-230V)

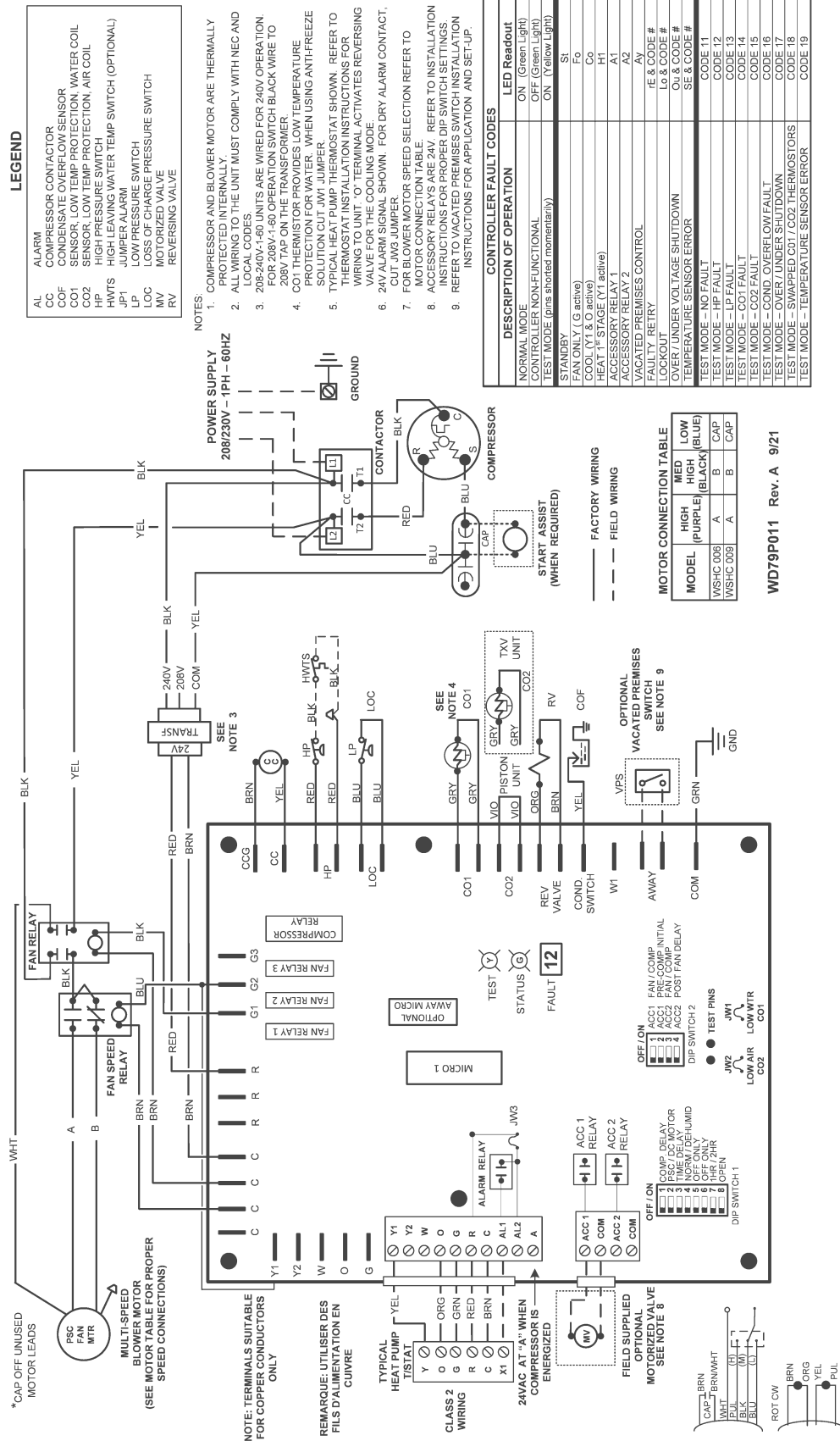

FIGURE 26 – WSHCE06/09(208-230V) * Wiring Diagram

WIRING DIAGRAMS

WSHC12-WIRING DIAGRAM (208-230V)

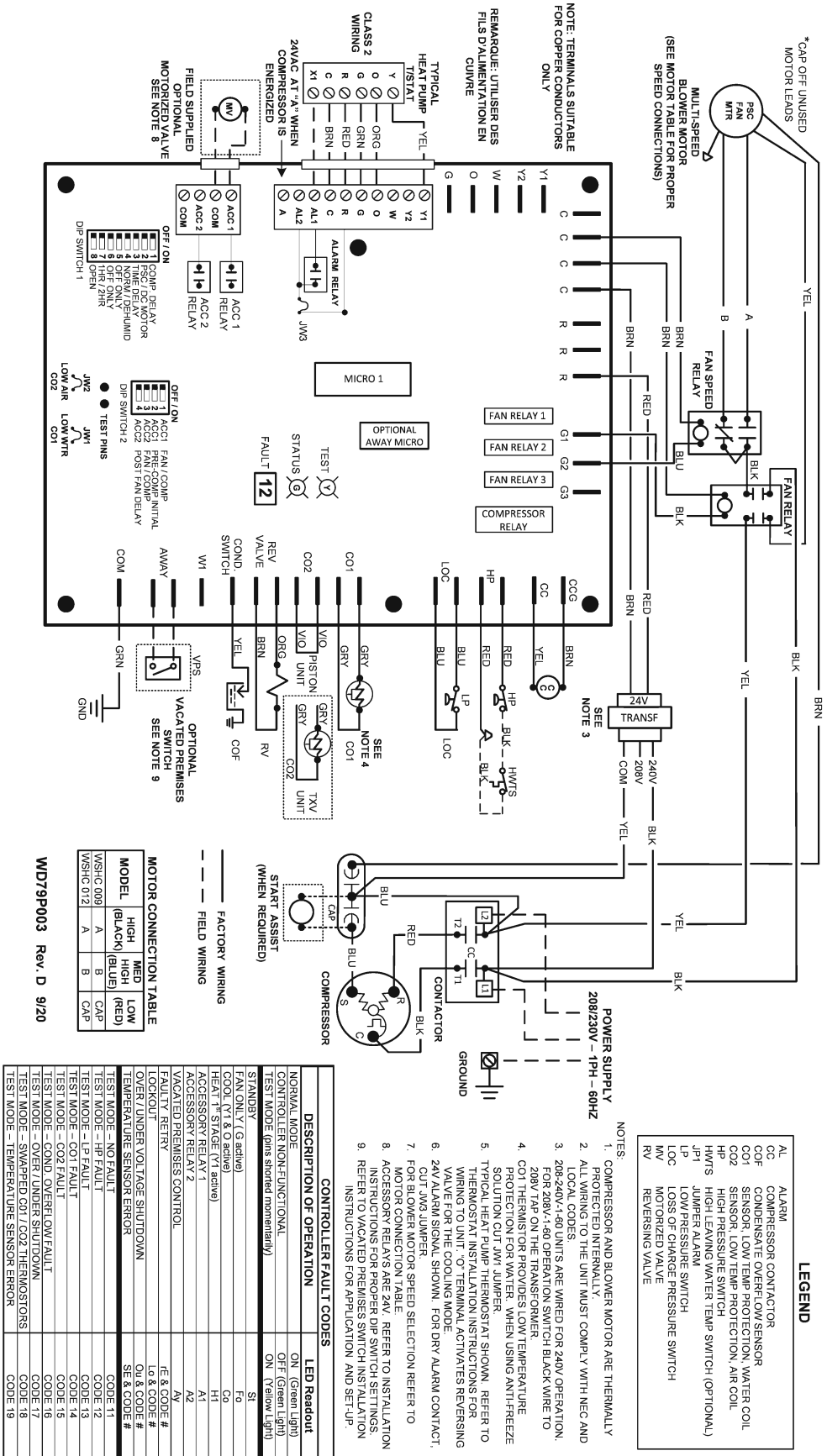

FIGURE 27 – WSHCE12(208-230V) * Wiring Diagram

WIRING DIAGRAMS

WSHCE06/09-WIRING DIAGRAM (265V)

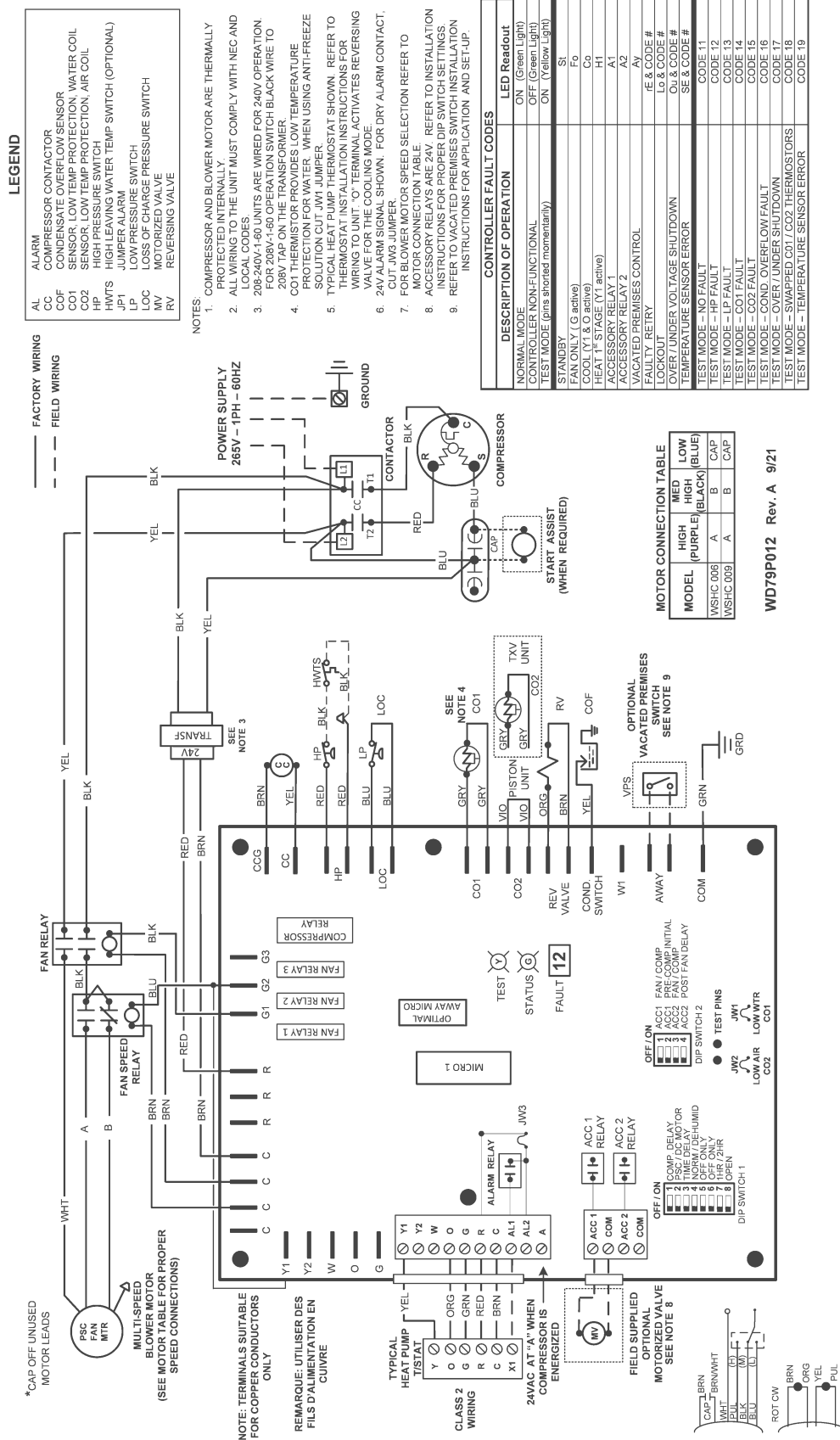

FIGURE 28 – WSHCE06/09(265V) Wiring Diagram

CIRCUIT SCHEMATIC

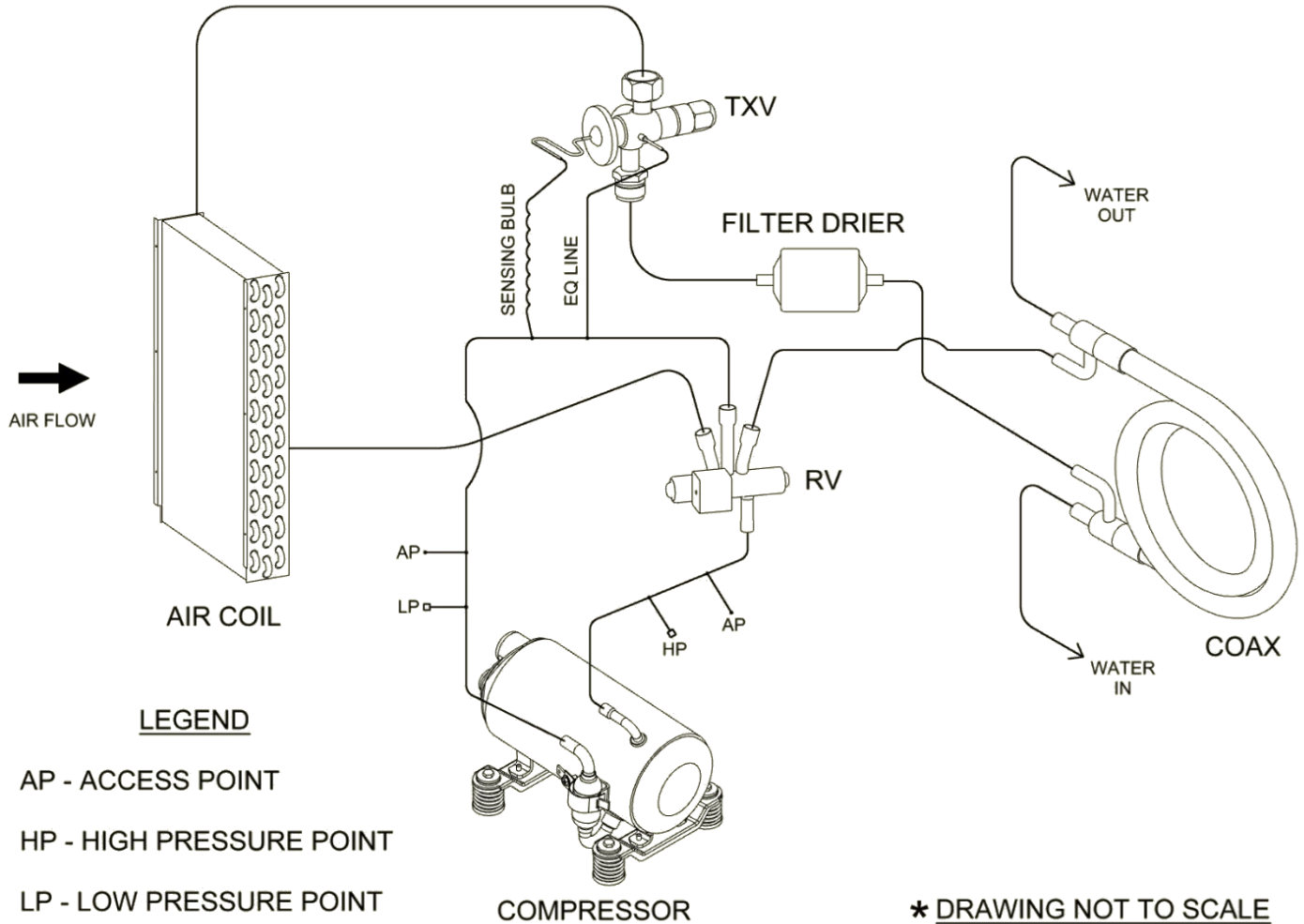

FIGURE 30 - Circuit Diagram

STARTUP INSTRUCTIONS

PRE-STARTUP CHECKS:

WARNING

Electrically ground the unit. Connect ground wire to ground lug. Failure to do so can result in injury or death.

CAUTION

Wire any field installed device such as a fan switch or thermostat furnished by the factory in strict accordance with the wiring diagram supplied with the unit. Failure to do so could result in damage to components and will void all warranties.

Before start-up, thoroughly check all the components. Optimal operation of equipment requires cleanliness. Often after installation of the equipment, additional construction

activities occur. Protect the equipment from debris during these construction phases.

PRIOR TO THE STARTUP OF THE UNIT:

1. Ensure supply voltage matches nameplate data.
2. Ensure the unit is properly grounded
3. With the power off, check blower wheel set screws for proper tightness and that the blower wheel rotates freely.
4. Ensure unit will be accessible for servicing.
5. Ensure condensate line is properly sized, run, trapped, pitched and tested.
6. Ensure all cabinet openings and wiring connections have been sealed.
7. Ensure clean filters are in place.
8. Ensure all access panels are in place and secured.

STARTUP INSTRUCTIONS CONTINUED

PRIOR TO THE STARTUP OF THE UNIT:

9. Check that the water coil and piping had been leak checked and insulated as required.
10. Ensure that all air has been vented from the water coil.
11. Make sure that all electrical connections are tight and secure.
12. Check the electrical overcurrent protection and wiring for the correct size.
13. Verify that the low voltage wiring between the thermostat and the unit matches the wiring diagram.
14. Verify that the water piping is complete and correct.
15. Check condensate overflow sensor for proper operation and adjust position if required. Ensure that power is connected to the unit and the local disconnect is switched to ON position.
12. Verify water flow rate is correct according to specification. Adjust if necessary. If specification is not available, the nominal flow rate for this unit is 25 GPM.
13. Instruct the owner on the unit and thermostat operation.

STARTUP & PERFORMANCE CHECKLIST INSTRUCTIONS

The warranty may be void unless the [FIGURE 31 – Startup & Performance Checklist](#) is completed and returned to the warrantor. If the FPG unit is not installed properly the warranty will be void as the manufacturer can't be held accountable for problems that stem from improper installation.

UNIT STARTUP:

1. Turn the disconnect switch to ON position.
2. Check for 24 volt from control transformer. Controller module LED should light up. If not, the power supply lines are out of phase. Turn of the main power disconnect to the unit off and change the phase.by switching any two incoming wires.
3. Set the thermostat to the lowest position. Turn the system switch to “COOL” and the fan switch to “AUTO” position. The reversing valve should energize.
4. After 5 minutes (anti-short cycle protect delay), the fan start at low speed and the compressor is running.
5. Make sure that compressor rotation is correct. If not, turn the power off and make the correction. This is 3-phase unit. Switching compressor rotation could be done by switching any two of compressor wires.
6. Turn the thermostat system to “OFF” position. The unit should stop running and the reversing valve de-energizes.
7. Leave the unit off for approximately 5 minutes to allow the system pressures to equalize. Anti-short cycle feature built in the system will keep the compressor off for 5 minutes.
8. Set the thermostat to the highest setting. Turn the system switch to “HEAT” position.
9. Verify that the unit is operating to the heating mode.
10. Set the thermostat to maintain the desired space temperature.
11. Check for vibrations, leaks, etc.

MAINTENANCE & SERVICE

PREVENTIVE MAINTENANCE

To achieve maximum performance and service life of equipment, a formal schedule of regular maintenance should be established and adhered to.



CAUTION



All appropriate personal protection equipment should be worn when servicing or maintaining this unit. Personal injury can result from sharp metal edges, moving parts, and hot or cold surfaces.

FAN

The fan should be inspected and cleaned annually in conjunction with maintenance of the motor and bearings. It is important to keep the fan section and motor clean and free from obstruction to prevent imbalance, vibration, and improper operation.



WARNING



ELECTRIC SHOCK HAZARD



Check motor connections to ensure they are secure and in accordance with the unit wiring diagram. ECM motors have line voltage power applied at all times. **MAKE SURE POWER IS DISCONNECTED BEFORE SERVICING.**

FILTER

The air filter should be cleaned or replaced every 30 days or more frequently if severe operating conditions exist. Always replace the filter with the same type and size as originally furnished.

COIL

Clean all heat transfer surfaces and remove all dirt, dust, and contaminants that potentially impairs air flow using industry accepted practices. Care should be taken not to bend coil fin material.

CONDENSATE DRAIN PAN AND PIPE

Check and clean all dirt and debris from pan. Ensure drain line is free flowing and unobstructed.

MAINTENANCE UPDATES

Check regularly for a current copy of the maintenance program log, which can be found at under “product information”.

CLEANING/FLUSHING

Before the unit is connected to the supply water, the water circulating system must be cleaned and flushed to remove any dirt or debris for the system.

1. Connect the supply and return water lines together in order to bypass the unit. This will prevent dirt or debris from getting into the system during the flushing process.
2. Start the main water circulating pump and allow for water to circulate in the system. Open drains at the lowest point in the system and drain out the water while simultaneously filling the loop with city water. Continue to exchange the loop water with the city water for a minimum of two hours, or until drain water is clear. During this time, check to make sure there are no leaks within the system.
3. Open all drains and vents to drain water system and refill with clean water. Test the system water quality and treat as necessary in order to bring water quality to within requirements for the system. Water PH level should be 7.5 to 8.5. Antifreeze may be added if required.
4. Connect the water-source heat pump supply and return lines, following proper installation procedures outlined in the piping installation section. After the installation has been checked for leaks, bring the water-loop to the desired set point and vent any air within the loop.

UNIT PERFORMANCE

Record performance measurements of volts, amps and water temperature differences (both heating and cooling). A comparison of logged data with start-up and other annual data is useful as an indicator of general equipment condition.

UNIT LOCKOUT

Air or water problem could cause periodic lockouts. The lockout (shutdown) of the units is a normal protective result. Check for dirt in the water system, water flow rates, water temperatures, airflow rates (may be caused by dirty filter) and air temperatures.

LABORATORY TESTING

When the unit has less than 100 operational hours and the coils have not had sufficient time to be “seasoned”, it is necessary to clean the coils with a mild surfactant such as Calgon to remove the oils left by manufacturing processes.

TROUBLESHOOTING

PROBLEM	POSSIBLE CAUSE	CHECKS & CORRECTIONS
ENTIRE UNIT DOES NOT RUN	Power supply off	Apply power; close disconnect.
	Blown Fuse	Replace fuse or reset circuit breaker. Check for correct fuses.
	Voltage supply low	If voltage is below minimum voltage specified on unit dataplate, contact lower power company. (Fault Code – Ou & 17).
	Thermostat	Set the fan to “ON”, the fan should run. Set thermostat to “COOL” and lowest temperature setting, the unit should run in the cooling mode (reversing valve energized). Set unit to “HEAT” and the highest temperature setting, the unit should run in the heating mode. If neither the blower nor compressor run in all three cases, the thermostat could be mis-wired or faulty. To ensure mis-wired or faulty thermostat verify 24 volts is available on the condenser section low voltage terminal strip between “R” and “C”, “Y” and “C”, and “O” and “C”. If blower does not operate, verify 24 volts between terminals “G” and “C” in the air handler. Replace the thermostat if defective.
BLOWER OPERATES BUT COMPRESSOR DOES NOT RUN	Thermostat	Check setting, calibration and wiring.
	Wiring	Check for loose or broken wires at compressor, capacitor or contractor.
	Safety Controls	Check control board fault LED for fault code.
	Compressor overload open	If the compressor is cool and the overload will not reset, replace the compressor.
	Compressor motor grounded	Internal wiring grounded to the compressor shell. Replace compressor. If compressor burnout, install new filter dryer.
	Compressor windings open	After compressor has cooled, check continually of compressor windings. If the windings are open, replace the compressor.
UNIT OFF ON HIGH PRESSURE CONTROL FAULT CODE 12	Discharge pressure too high	In “COOLING” mode: Lack of or inadequate water flow. Entering water temperature too warm. Scaled or restricted water to refrigerant heat exchanger. In “HEATING” mode: Lack of or inadequate water flow. Entering water temperature too cold. Scaled or restricted water to refrigerant heat exchanger.
	Refrigerant charge	The unit is overcharged with refrigerant. Reclaim refrigerant, evacuate and recharge with factory recommended charge.
	High pressure switch	Check for defective or improperly calibrated high pressure switch.
UNIT OFF ON LOW PRESSURE CONTROL FAULT CODE 13	Suction Pressure too low	In “COOLING” mode: Lack of or inadequate airflow. Entering air temperature too cold. Blower inoperative, clogged filter or restriction in ductwork. In “HEATING” mode: Lack of or inadequate water flow. Entering water temperature too cold. Scaled or restricted water to refrigerant heat exchanger.
	Refrigerant charge	The unit is low on refrigerant. Check for refrigerant leak, repair, evacuate and recharge with factor recommended charge.
	Low pressure switch	Check for defective or improperly calibrated low pressure switch.

Table 19 – Troubleshooting Table

TROUBLESHOOTING CONTINUED

PROBLEM	POSSIBLE CAUSE	CHECKS & CORRECTIONS
UNIT SHORT CYCLES	Unit oversized	Recalculate heating and cooling loads.
	Thermostat	Thermostat installed near a supply air register, relocate thermostat. Check heat anticipator.
	Wiring and controls	Loose connections in the wiring or a defective compressor contactor.
INSUFFICIENT COOLING OR HEATING	Unit undersized	Recalculate heating and cooling loads. If not excessive, possibly adding insulation will rectify the situation.
	Loss of conditioned air by leaks	Check for leaks in ductwork or introduction of ambient air through doors or windows.
	Airflow	Lack of adequate airflow or improper distribution of air. Replace dirty air filter.
	Refrigerant charge	Low on refrigerant charge causing inefficient operation.
	Compressor	Check for defective compressor. If discharge is too low and suction pressure is too high, compressor is not pumping properly. Replace compressor.
	Reversing valve	Defective reversing valve creating bypass of refrigerant from discharge to suction side of compressor. Discharge is too low and suction is too high. Replace reversing valve.
	Operating pressures	Compare unit operating pressures to the pressure / temperature chart for the unit.
	Refrigerant metering device	Check for possible restriction or defect. Replace is necessary.
Moisture, non-condensables	The refrigerant system may be contaminated with moisture or non-condensables. Reclaim refrigerant, evacuate and recharge with factory recommended charge. Replace filter dryer.	

Table 20 – Troubleshooting Table Continued

SUPPORT/REFERENCE MATERIAL

REFERENCE CALCULATIONS

HEATING

$$LDB = EDB + \frac{QH}{GPM \times 500}$$

$$LWT = EAT + \frac{QA}{cfm \times 1.08}$$

COOLING

$$LDB = EDB - \frac{SC}{cfm \times 1.08}$$

$$LWT = EWT + \frac{QR}{GPM \times 500}$$

$$LC = QC - SC$$

$$SHR = \frac{SC}{QC}$$

ABBREVIATIONS & DEFINITIONS

LDB = Leaving air temperature dry bulb °F

EDB = Entering air temperature dry bulb °F

GPM = Water flow rate gallons per minute

CFM = Airflow rate cubic feet per minute

QH = Heating capacity Btuh

QA = Heat of absorption Btuh

SC = Sensible cooling capacity Btuh

QR = Heat of rejection Btuh

LC = Latent cooling capacity Btuh

SHR = Sensible heat ratio

COMMON CONVERSIONS

Air Flow	l/s = CFM x .47
Water Flow	l/s = GPM x .06
Static Pressure	Pa = IWC x 249
Water Pressure Drop	FOH = PSI x 2.3
Temperature	°C = (°F - 32) x 5/9
Power	kW = Btuh / 3412
Weight	oz = lb x 16
Weight	kg = lb / 2.2
EER	COP x 3.413
COP	EER / 3.413

STARTUP & PERFORMANCE CHECKLIST



CUSTOMER _____ DATE _____ STARTUP DATE _____
 ADDRESS _____ PHONE # _____ JOB NUMBER _____
 HYDROTECH MODEL _____ SERVICING COMPANY _____
 SERIAL # _____ TECHNICIAN _____
 SERIAL # EXAMPLE (1 Letter) – (2 #s) – (1 letter) – (6 #s)

VISUAL INSPECTION

- Air Filter Condition
- Evaporate Coil Condition
- Blower Wheel
- Signs of sweating on plenum / cabinet
- Signs of condensate outside pan
- Condensate Drain Clear

ACCESSORIES INSTALLED

- Hard Start Kit
Type/Brand: _____
- Compressor Cover
- Vacated Premises Switch

CONTROL MODULE SWITCH POSITION

Dip Switch #1

Off	On
<input type="checkbox"/>	<input type="checkbox"/>
<input type="checkbox"/>	<input type="checkbox"/>
<input type="checkbox"/>	<input type="checkbox"/>
<input type="checkbox"/>	<input type="checkbox"/>
<input type="checkbox"/>	<input type="checkbox"/>
<input type="checkbox"/>	<input type="checkbox"/>
<input type="checkbox"/>	<input type="checkbox"/>
<input type="checkbox"/>	<input type="checkbox"/>

- Switch #1
- Switch #2
- Switch #3
- Switch #4
- Switch #5
- Switch #6
- Switch #7
- Switch #8

Dip Switch #2

Off	On
<input type="checkbox"/>	<input type="checkbox"/>
<input type="checkbox"/>	<input type="checkbox"/>
<input type="checkbox"/>	<input type="checkbox"/>
<input type="checkbox"/>	<input type="checkbox"/>

- Switch #1
- Switch #2
- Switch #3
- Switch #4

Unit in Lock Out? _____

Fault Code Displayed in Test Mode? _____

PROBLEM SUMMARY

CORRECTIVE ACTIONS TAKEN

UNIT OPERATION

Primary Voltage to the Heat Pump: _____
 Transformer Secondary Voltage: _____
 Unit Grounded? _____
 Low Side PSIG: _____ Vapor Line Temp: _____ Saturated Temp: _____
 [Vapor Line Temp – Saturated Temp = **Superheat**]*
 High Side PSIG: _____ Saturated Temp: _____ Liquid Line Temp: _____
 [Saturated Temp – Liquid Line Temp = **Sub Cooling**]*

DUCT SYSTEM STATIC PRESSURE

Supply Static Pressure: _____
 Return Static Pressure: _____
 Total External Static Pressure: _____

EVAPORATOR COIL TEMPERATURES:

Evaporator Coil EAT Dry Bulb: _____
 Evaporator Coil LAT Dry Bulb: _____
 Delta: _____
 Evaporator Coil EAT Dry Bulb: _____
 Evaporator Coil EAT Dry Bulb: _____
 Delta: _____

HEAT EXCHANGER TEMPERATURE

Cond Entering Water Temp: _____
 Cond Leaving Water Temp: _____
 Cond Temp Rise: _____

The warranty may be void unless the Startup & Performance Checklist is completed and returned to the warrantor. If the HVAC unit is not installed properly the warranty will be void as the manufacturer can't be held accountable for problems that stem from improper installation.

FIGURE 31 – Startup and Performance Checklist

NOTES

NOTES

NOTES

Manufactured by:



8273 Moberly Lane
Dallas, TX 75227
www.firstco.com

The manufacturer works to continually improve its products and as a result, it reserves the right to change design and specifications without notice.

©2021 First Co., 8273 Moberly Lane, Dallas, TX 75227