



RR • RM • RS

Vertical High Rise Fan Coils
Chilled Water Cooling with
Hot Water or Electric Heat
Vertical 300-1200 CFM

Multiple Floor Applications

PSC Motor or ECM Motor

- Hospitality
- Office
- Educational
- Healthcare



Table of Contents

<p>Nomenclature Standard Features Physical Data Configurations Blower Performance Electric Heat Data</p>	<p>2 3-13 14 15 16</p>	<p>Motor Data Cooling Capacity Heating Capacity Supply Grill Data Return Access Panel Data Guide Specifications</p>	<p>16 17 18 19 20 22-24</p>
--	--	---	---

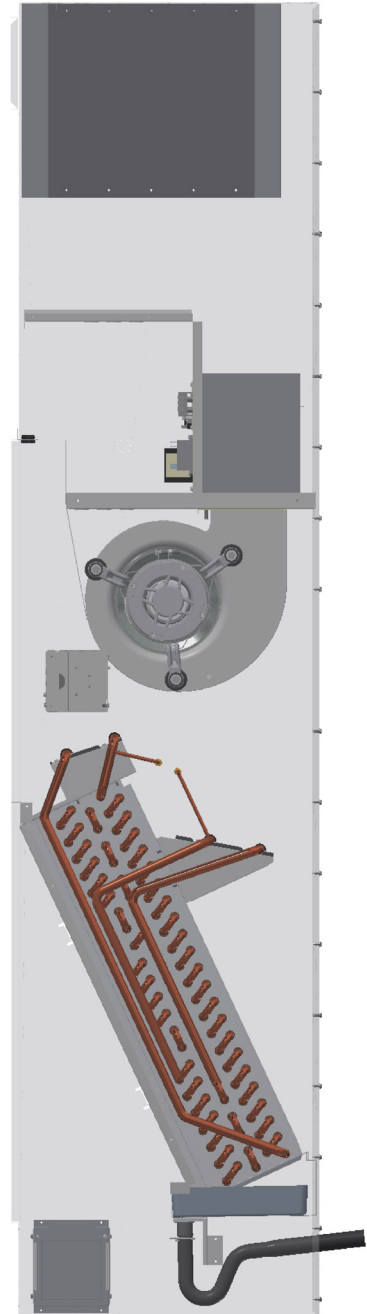
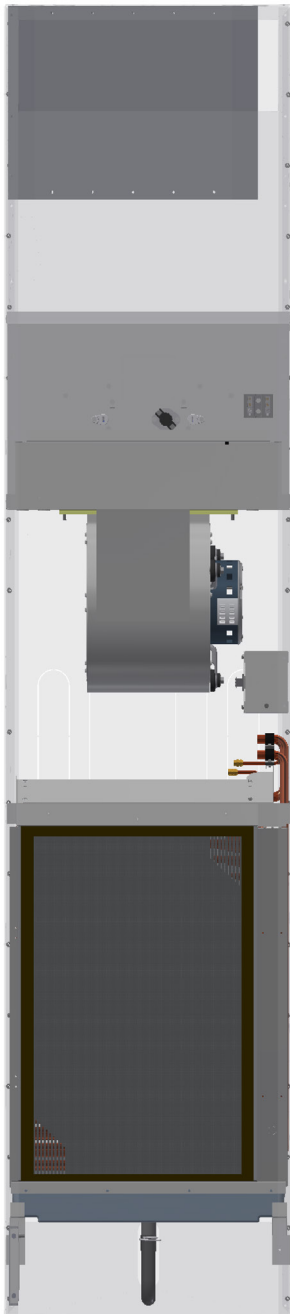

Standard Features

Cabinet external and internal parts are fabricated from a minimum of 20 gauge galvanized steel. Construction allows for large access panels to permit full access to internal components. The structural integrity of the cabinets remain unaffected by the removal of any or all access panels.

Insulation shall be blanket-type made from glass fibers bonded with a thermosetting resin. Insulation shall be 3/4 inch thick antimicrobial coated Tuf-skin RX providing effective acoustical and thermal control, fire safety, and resistance to air erosion. This insulation meets the requirements of ASTM C 1071, ASTM G 21, ASTM G22, NFPA 90A and UL-181.

Coils are 1/2 inch staggered tube type construction with seamless copper tubes and headers and deep corrugated aluminum fins with straight edges. Fins are manufactured with full depth collars, drawn in the fin stock to provide accurate control of fin spacing and completely cover the copper tubes to lengthen coil life. The tubes are to be mechanically expanded into the fins for a permanent primary to secondary surface bond, assuring maximum heat transfer efficiency. The coils are to be tested at 350 pounds air pressure for operation at 300 PSI gauge working pressure. Coils include a manual air vent.

Cooling/Heating options include 2-pipe, 4-pipe or 2-pipe with electric heat.

Drain pans are removable and formed from heavy gauge galvanized steel or optional 304 stainless steel and is coated inside with insulation. The drain pan is factory piped to the drain riser that has a removable "p-trap" for easy cleaning.

Fan Wheels are double width, double inlet (DWDI), forward curved, centrifugal type. They are statically and dynamically balanced for smooth, quiet operation. The housing is constructed of heavy gauge galvanized steel with die-formed inlet cones.

Motor is a 3-speed, 115-v, single phase, 60-Hz, permanent split capacitor type, factory mounted on the blower housing. Bearings are sealed sleeve type.

Filters are 1" disposable type. The filters are included in the units as an integral part of the cabinet with easy access.

Risers are factory-furnished and installed. Standard risers are 115-in. long with 3-in. belled ends at the top such that only one sweat connection will be required at each floor to join one riser to another. Standard risers are copper insulated with 3/4-in. thick synthetic rubber.

Valve packages are factory assembled for installation inside cabinet. Power-heads include quick connect wiring harness.

115/24v controls include 3-speed control board factory mounted with a quick connect plug for field-mounting of thermostat on the front of unit.

Optional Features:

Return air/access panel is fabricated from heavy gauge galvanized steel with stamped louvers, powder coated and equipped with tamper proof fasteners.

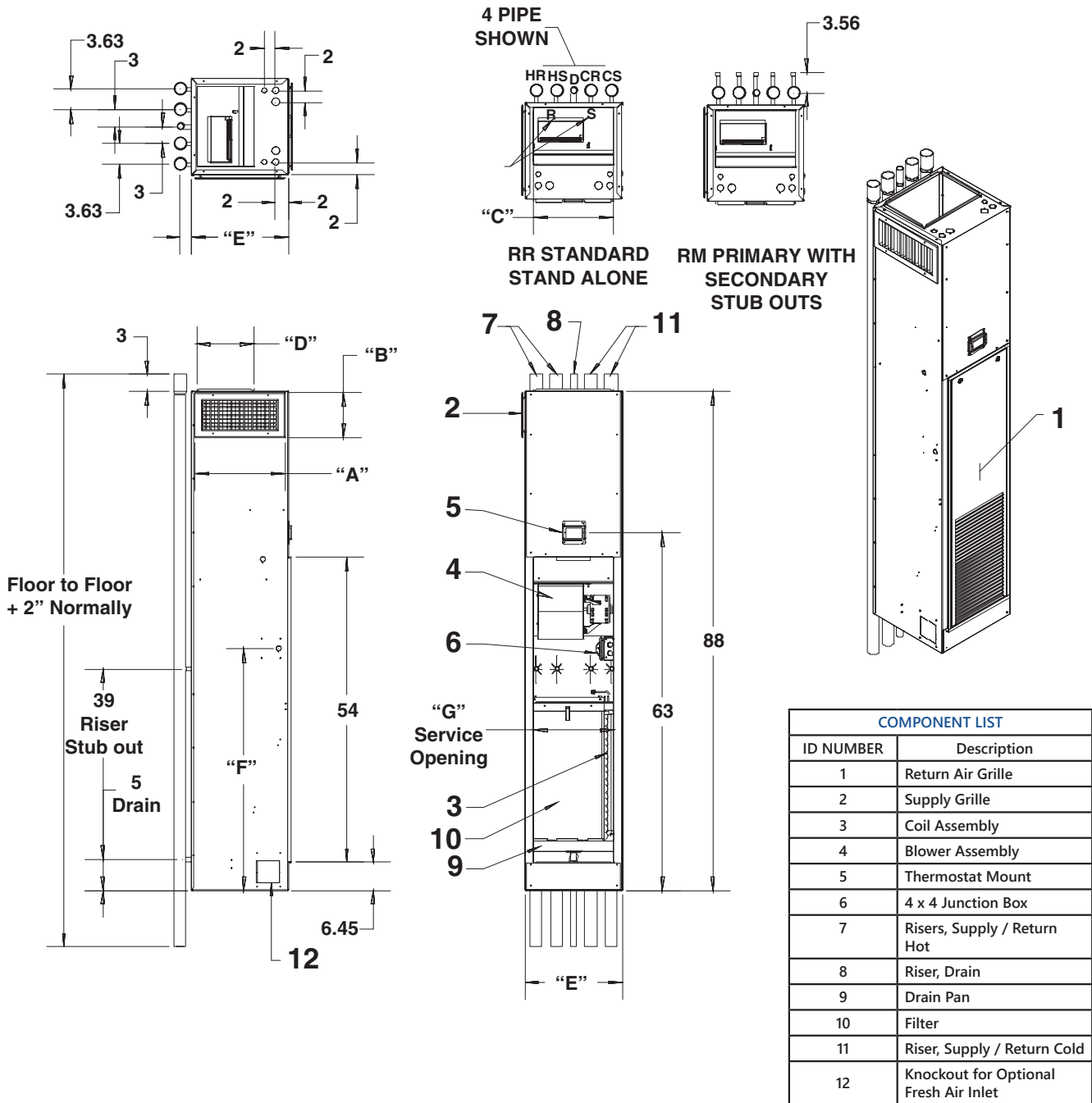

MODEL	SINGLE SUPPLY OPENING			DOUBLE SUPPLY OPENING (2)			TOP SUPPLY OPENING						
	A	B	SIZE	A	B	SIZE	C	D	SIZE	E	F	G	FILTER SIZE
3RR/RM				14	6	14 X 6	14	10	14 X 10	17	42.62	14.13	12.5 X 24.25 X 1
4RR/RM				14	6	14 X 6	14	10	14 X 10	17	42.62	14.13	12.5 X 24.25 X 1
6RR/RM				18	6	18 X 6	16	12	16 X 12	20	42.62	18.13	16.25 X 26.75 X 1
8RR/RM				18	6	18 X 6	16	12	16 X 12	20	42.62	18.13	16.25 X 26.75 X 1

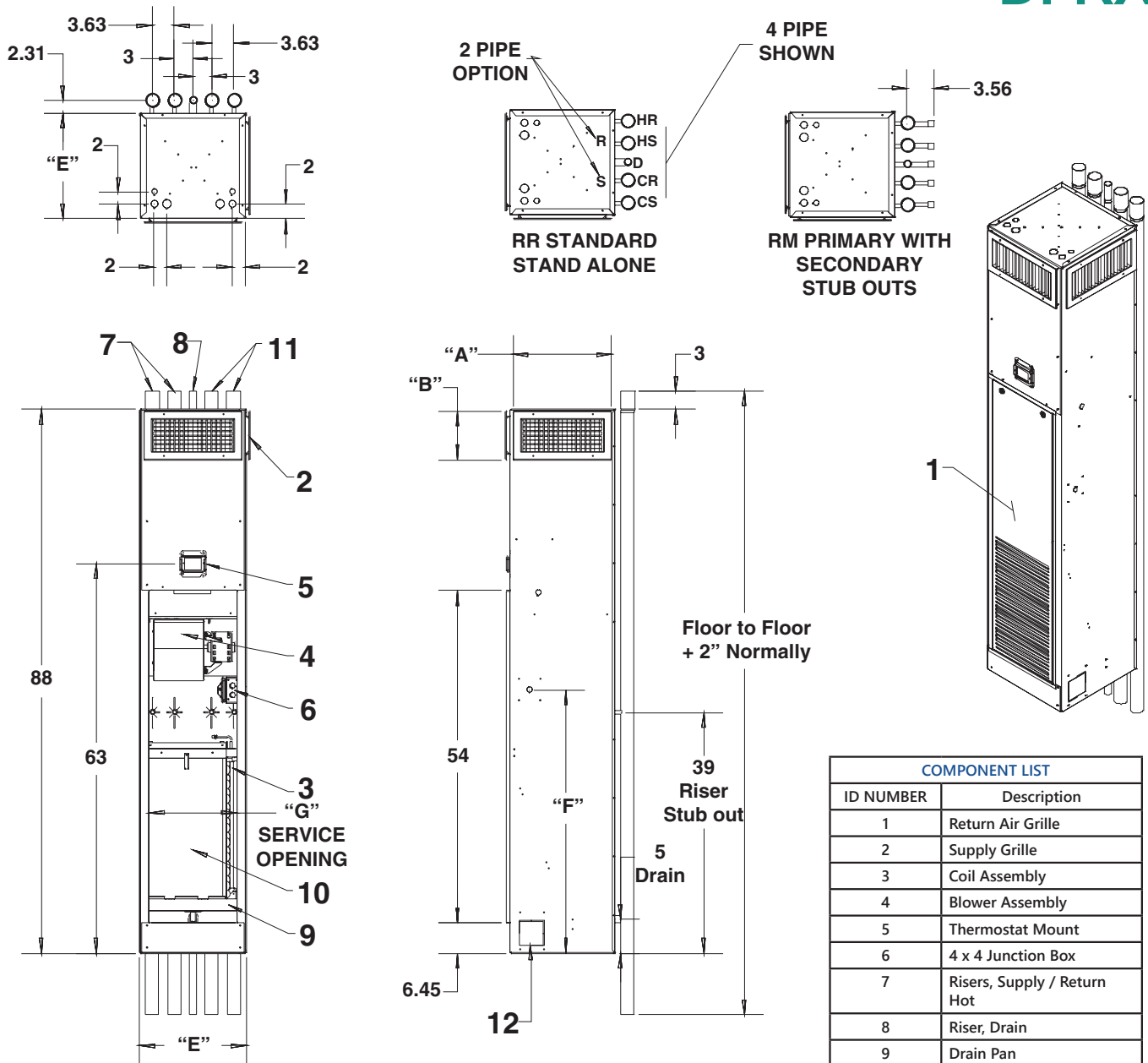

COMPONENT LIST	
ID NUMBER	Description
1	Return Air Grille
2	Supply Grille
3	Coil Assembly
4	Blower Assembly
5	Thermostat Mount
6	4 x 4 Junction Box
7	Risers, Supply / Return Hot
8	Riser, Drain
9	Drain Pan
10	Filter
11	Riser, Supply / Return Cold
12	Knockout for Optional Fresh Air Inlet

MODEL	SINGLE SUPPLY OPENING			DOUBLE SUPPLY OPENING (2)			TOP SUPPLY OPENING						
	A	B	SIZE	A	B	SIZE	C	D	SIZE	E	F	G	FILTER SIZE
3RR/RM				14	6	14 X 6				17	42.62	14.13	12.5 X 24.25 X 1
4RR/RM				14	6	14 X 6				17	42.62	14.13	12.5 X 24.25 X 1
6RR/RM				18	6	18 X 6				20	42.62	18.13	16.25 X 26.75 X 1
8RR/RM				18	6	18 X 6				20	42.62	18.13	16.25 X 26.75 X 1
10RR/RM				22	8	22 X 8				24	42.62	22.13	20.50 X 29.25 X 1
12RR/RM				22	8	22 X 8				24	42.62	22.13	20.50 X 29.25 X 1

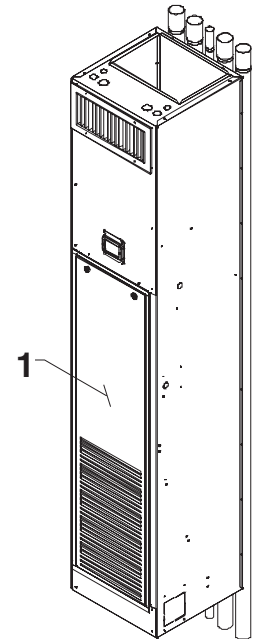
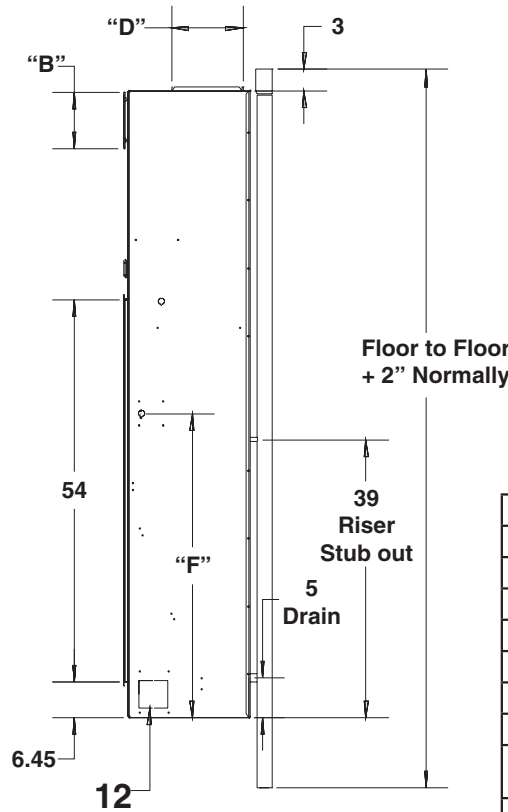
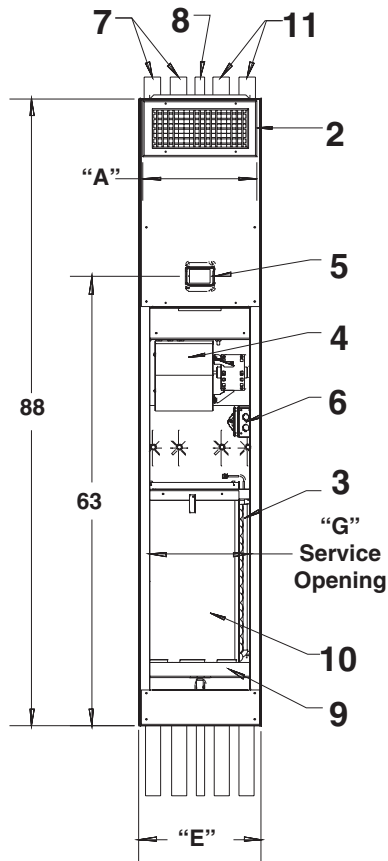
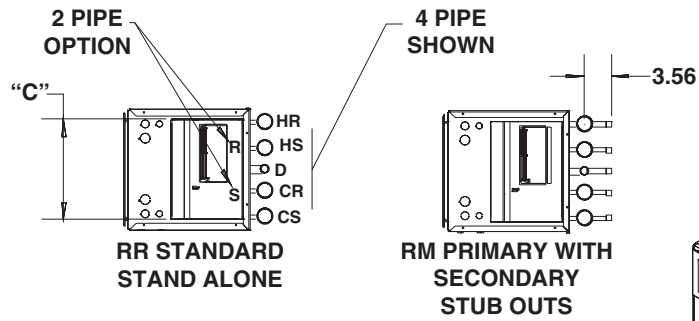
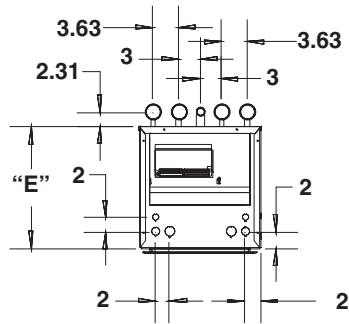

COMPONENT LIST	
ID NUMBER	Description
1	Return Air Grille
2	Supply Grille
3	Coil Assembly
4	Blower Assembly
5	Thermostat Mount
6	4 x 4 Junction Box
7	Risers, Supply / Return Hot
8	Riser, Drain
9	Drain Pan
10	Filter
11	Riser, Supply / Return Cold
12	Knockout for Optional Fresh Air Inlet

MODEL	SINGLE SUPPLY OPENING			DOUBLE SUPPLY OPENING (2)			TOP SUPPLY OPENING			E	F	G	FILTER SIZE
	A	B	SIZE	A	B	SIZE	C	D	SIZE				
3RR/RM				14	6	14 X 6	14	10	14 X 10	17	42.62	14.13	12.5 X 24.25 X 1
4RR/RM				14	6	14 X 6	14	10	14 X 10	17	42.62	14.13	12.5 X 24.25 X 1
6RR/RM				18	6	18 X 6	16	12	16 X 12	20	42.62	18.13	16.25 X 26.75 X 1
8RR/RM				18	6	18 X 6	16	12	16 X 12	20	42.62	18.13	16.25 X 26.75 X 1
10RR/RM				22	8	22 X 8	18	16	18 X 16	24	42.62	22.13	20.50 X 29.25 X 1
12RR/RM				22	8	22 X 8	18	16	18 X 16	24	42.62	22.13	20.50 X 29.25 X 1

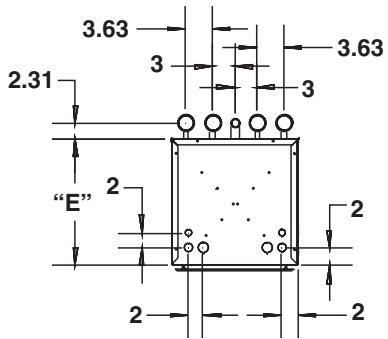

2 PIPE OPTION

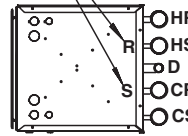

RR STANDARD STAND ALONE

4 PIPE SHOWN

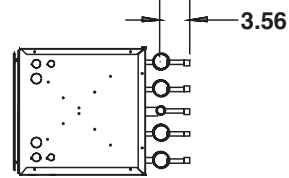

RM PRIMARY WITH SECONDARY STUB OUTS

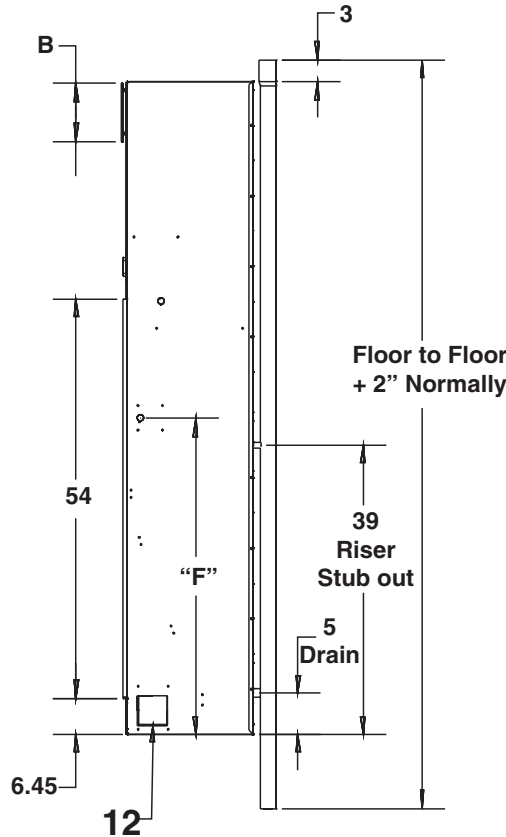
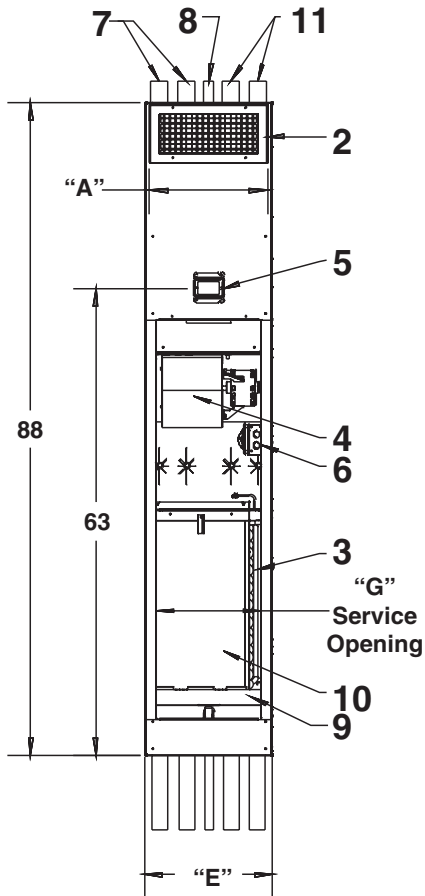
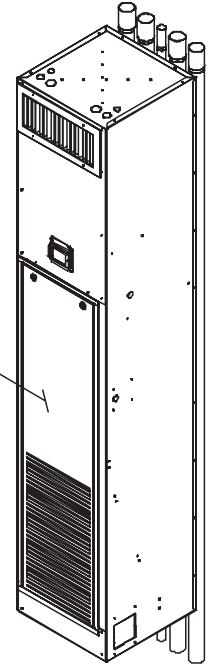

COMPONENT LIST	
ID NUMBER	Description
1	Return Air Grille
2	Supply Grille
3	Coil Assembly
4	Blower Assembly
5	Thermostat Mount
6	4 x 4 Junction Box
7	Risers, Supply / Return Hot
8	Riser, Drain
9	Drain Pan
10	Filter
11	Riser, Supply / Return Cold
12	Knockout for Optional Fresh Air Inlet

MODEL	SINGLE SUPPLY OPENING (1)			DOUBLE SUPPLY OPENING			TOP SUPPLY OPENING						
	A	B	SIZE	A	B	SIZE	C	D	SIZE	E	F	G	FILTER SIZE
3RR/RM	14	8	14 X 8							17	42.62	14.13	12.5 X 24.25 X 1
4RR/RM	14	12	14 X 12							17	42.62	14.13	12.5 X 24.25 X 1
6RR/RM	18	10	18 X 10							20	42.62	18.13	16.25 X 26.75 X 1
8RR/RM	18	12	18 X 12							20	42.62	18.13	16.25 X 26.75 X 1

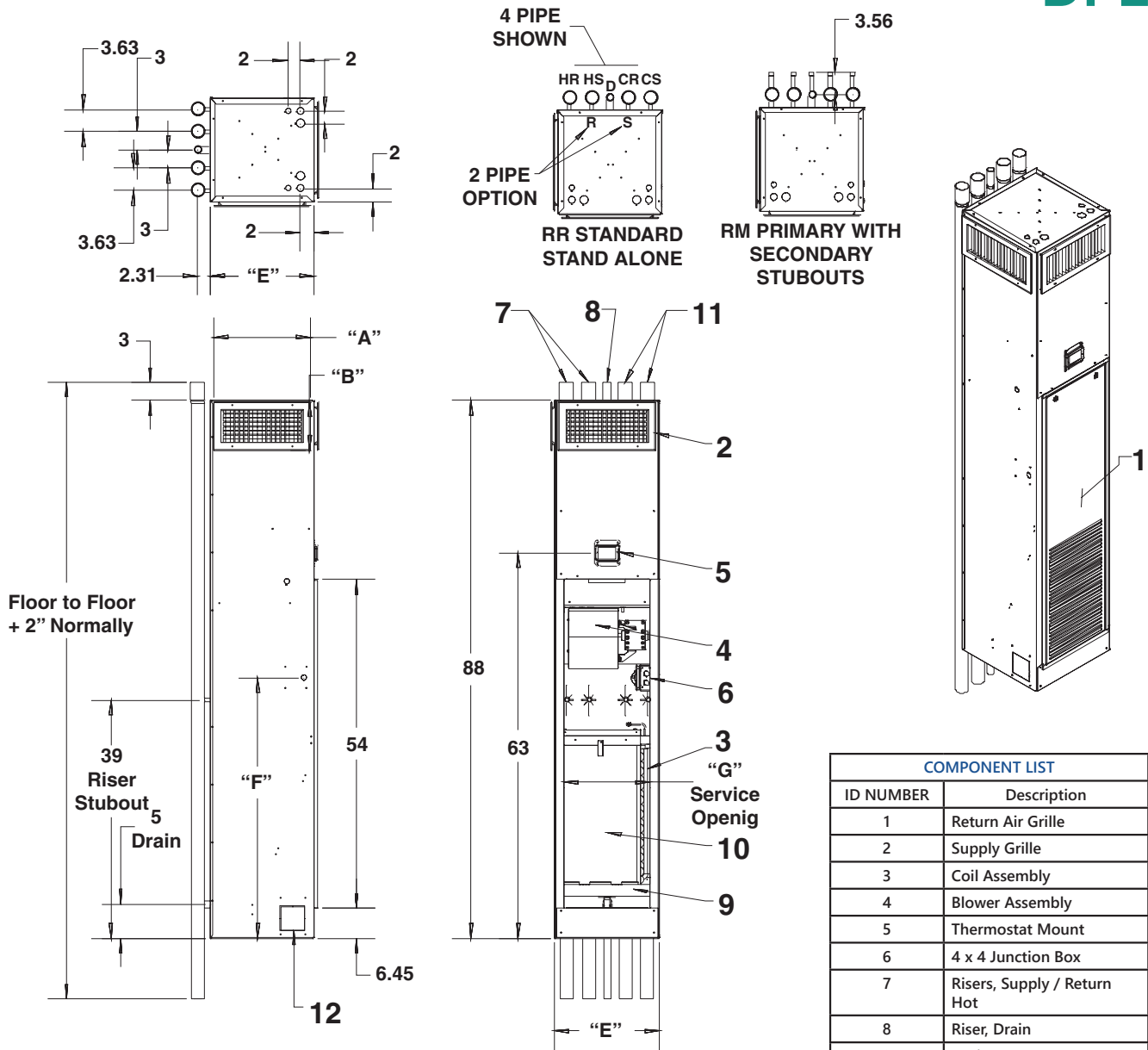

COMPONENT LIST	
ID NUMBER	Description
1	Return Air Grille
2	Supply Grille
3	Coil Assembly
4	Blower Assembly
5	Thermostat Mount
6	4 x 4 Junction Box
7	Risers, Supply / Return Hot
8	Riser, Drain
9	Drain Pan
10	Filter
11	Riser, Supply / Return Cold
12	Knockout for Optional Fresh Air Inlet

MODEL	SINGLE SUPPLY OPENING			DOUBLE SUPPLY OPENING (2)			TOP SUPPLY OPENING			E	F	G	FILTER SIZE
	A	B	SIZE	A	B	SIZE	C	D	SIZE				
3RR/RM				14	6	14X6				17	42.62	14.13	12.5 X 24.25 X 1
4RR/RM				14	6	14X6				17	42.62	14.13	12.5 X 24.25 X 1
6RR/RM				18	6	18X6				20	42.62	18.13	16.25 X 26.75 X 1
8RR/RM				18	6	18X6				20	42.62	18.13	16.25 X 26.75 X 1
10RR/RM				22	8	22X8				24	42.62	22.13	20.50 X 29.25 X 1
12RR/RM				23	8	22X8				24	42.62	22.13	20.50 X 29.25 X 1

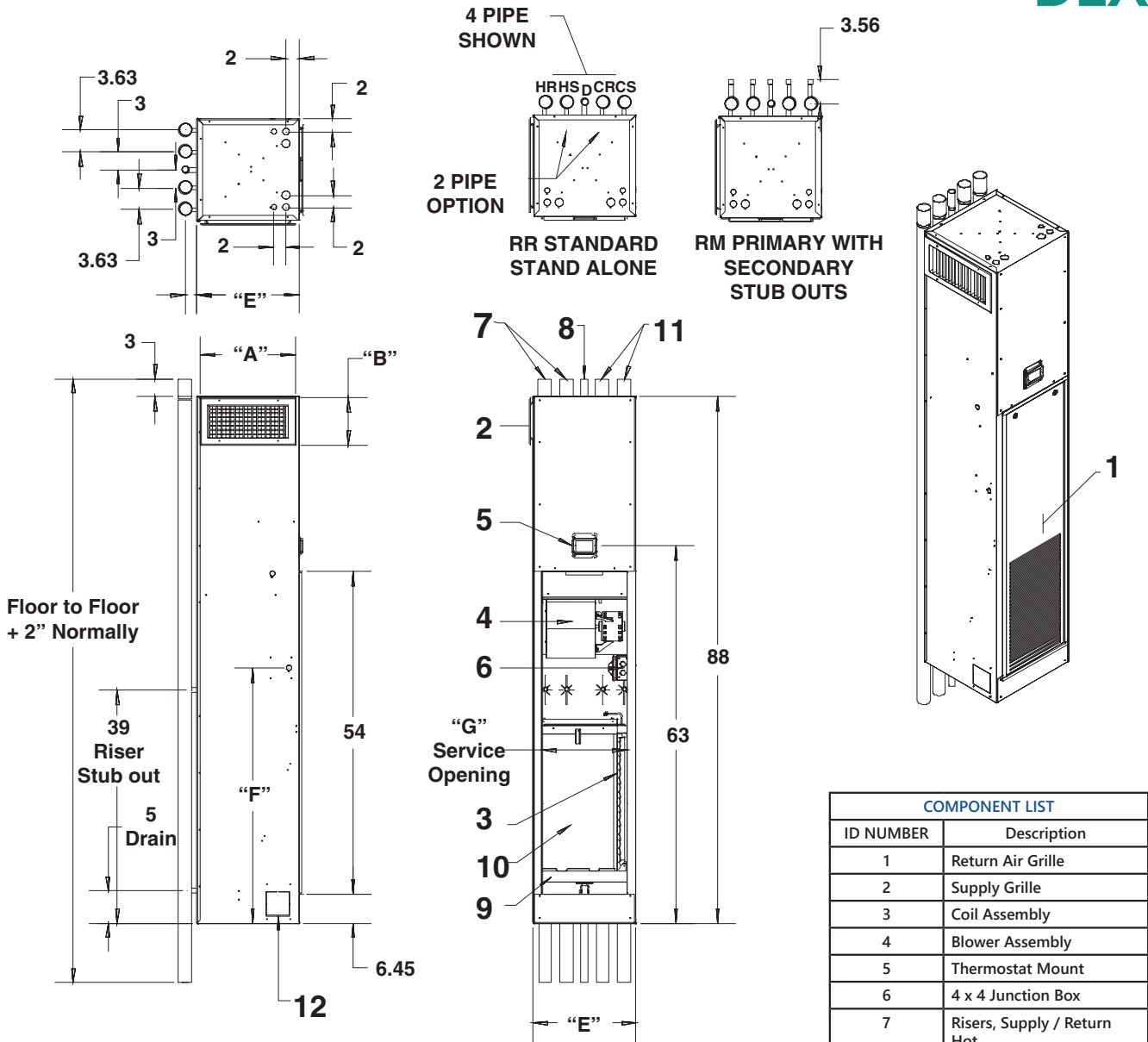

COMPONENT LIST	
ID NUMBER	Description
1	Return Air Grille
2	Supply Grille
3	Coil Assembly
4	Blower Assembly
5	Thermostat Mount
6	4 x 4 Junction Box
7	Risers, Supply / Return Hot
8	Riser, Drain
9	Drain Pan
10	Filter
11	Riser, Supply / Return Cold
12	Knockout for optional Fresh Air Inlet

MODEL	SINGLE SUPPLY OPENING (1)			DOUBLE SUPPLY OPENING			TOP SUPPLY OPENING						
	A	B	SIZE	A	B	SIZE	C	D	SIZE	E	F	G	FILTER SIZE
3RR/RM	14	8	14X8							17	42.62	14.13	12.5 X 24.25 X 1
4RR/RM	14	12	14X12							17	42.62	14.13	12.5 X 24.25 X 1
6RR/RM	18	10	18X10							20	42.62	18.13	16.25 X 26.75 X 1
8RR/RM	18	12	18X12							20	42.62	18.13	16.25 X 26.75 X 1

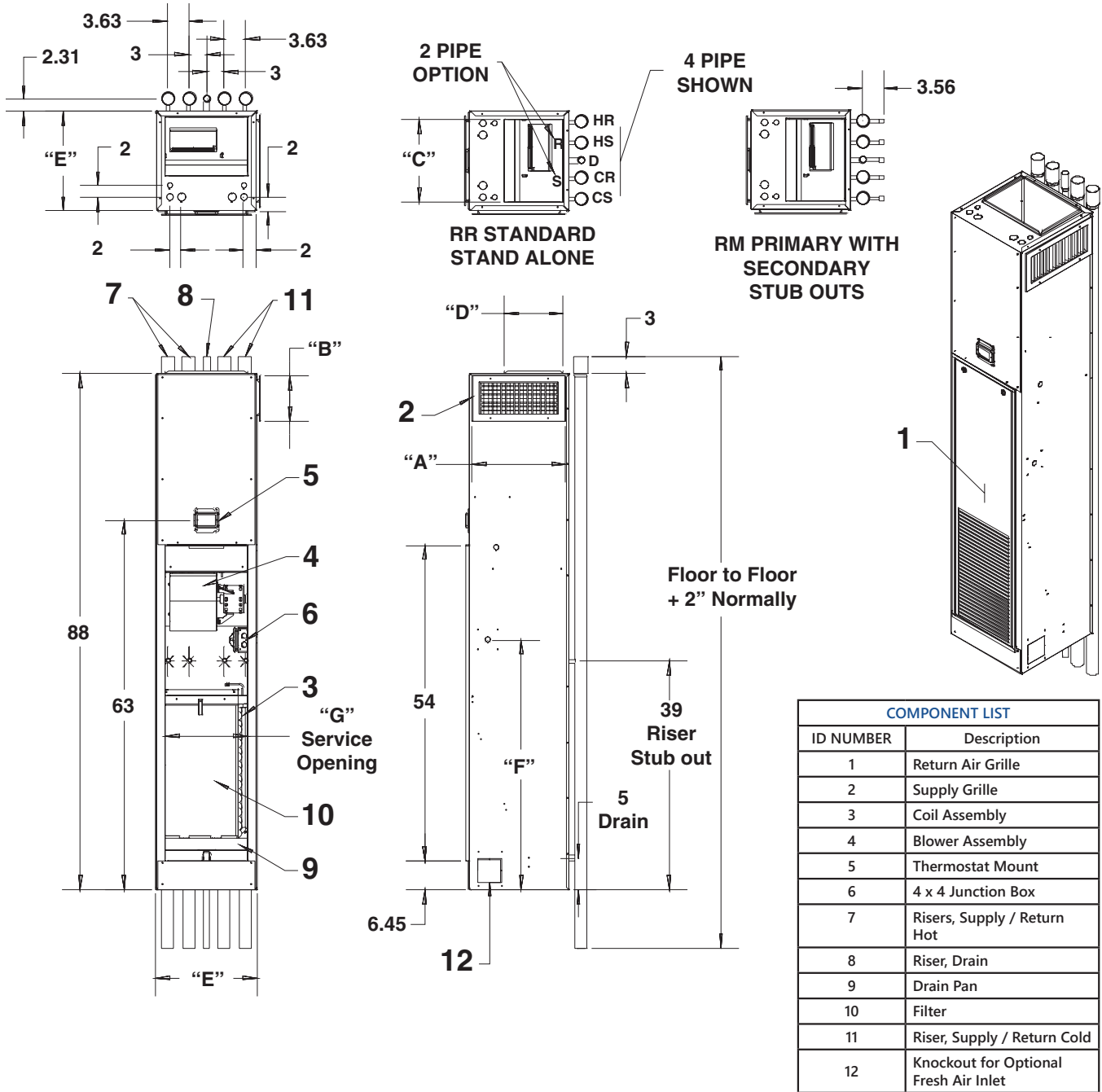

MODEL	SINGLE SUPPLY OPENING			DOUBLE SUPPLY OPENING (2)			TOP SUPPLY OPENING			E	F	G	FILTER SIZE
	A	B	SIZE	A	B	SIZE	C	D	SIZE				
3RR/RM				14	6	14 X 6	14	10	14 X 10	17	42.62	14.13	12.5 X 24.25 X 1
4RR/RM				14	6	14 X 6	14	10	14 X 10	17	42.62	14.13	12.5 X 24.25 X 1
6RR/RM				18	6	18 X 6	16	12	16 X 12	20	42.62	18.13	16.25 X 26.75 X 1
8RR/RM				18	6	18 X 6	16	12	16 X 12	20	42.62	18.13	16.25 X 26.75 X 1
10RR/RM				22	8	22 X 8	18	16	18 X 16	24	42.62	22.13	20.50 X 29.25 X 1
12RR/RM				22	8	22 X 8	18	16	18 X 16	24	42.62	22.13	20.50 X 29.25 X 1

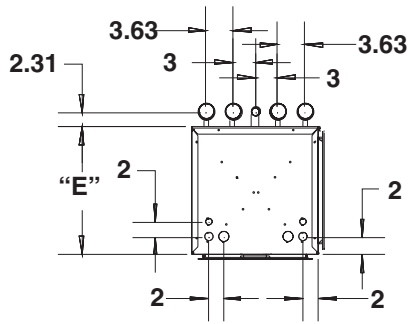

2 PIPE OPTION

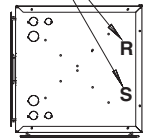

RR STANDARD STAND ALONE

4 PIPE SHOWN

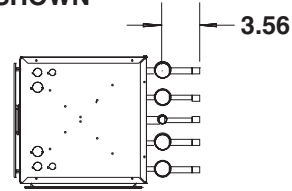

RM MASTER WITH SECONDARY STUB OUTS

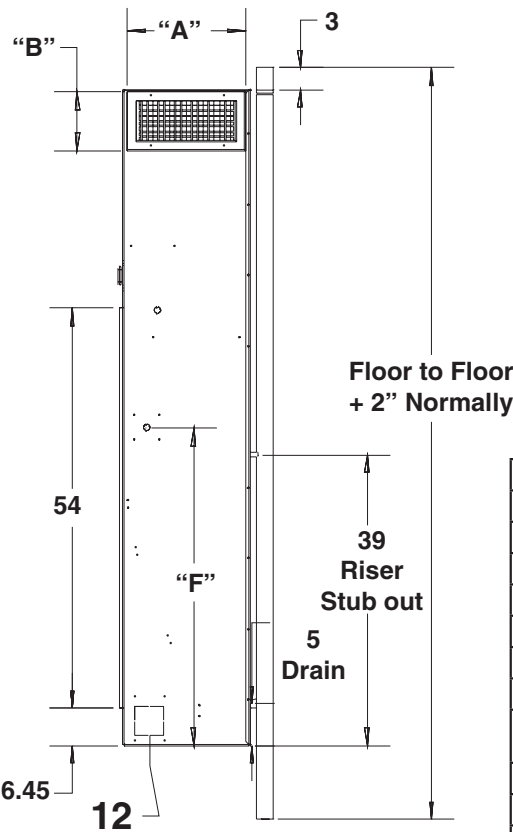
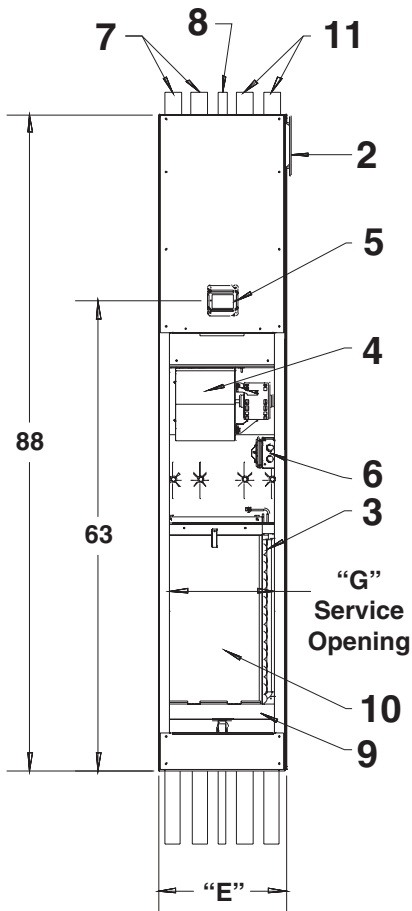
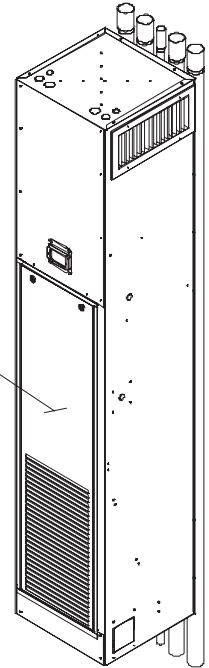

COMPONENT LIST	
ID NUMBER	Description
1	Return Air Grille
2	Supply Grille
3	Coil Assembly
4	Blower Assembly
5	Thermostat Mount
6	4 x 4 Junction Box
7	Risers, Supply / Return Hot
8	Riser, Drain
9	Drain Pan
10	Filter
11	Riser, Supply / Return Cold
12	Knockout for Optional Fresh Air Inlet

MODEL	SINGLE SUPPLY OPENING (1)			DOUBLE SUPPLY OPENING			TOP SUPPLY OPENING						
	A	B	SIZE	A	B	SIZE	C	D	SIZE	E	F	G	FILTER SIZE
3RR/RM	14	8	14 X 8							17	42.62	14.13	12.5 X 24.25 X 1
4RR/RM	14	12	14 X 12							17	42.62	14.13	12.5 X 24.25 X 1
6RR/RM	18	10	18 X 10							20	42.62	18.13	16.25 X 26.75 X 1
8RR/RM	18	12	18 X 12							20	42.62	18.13	16.25 X 26.75 X 1

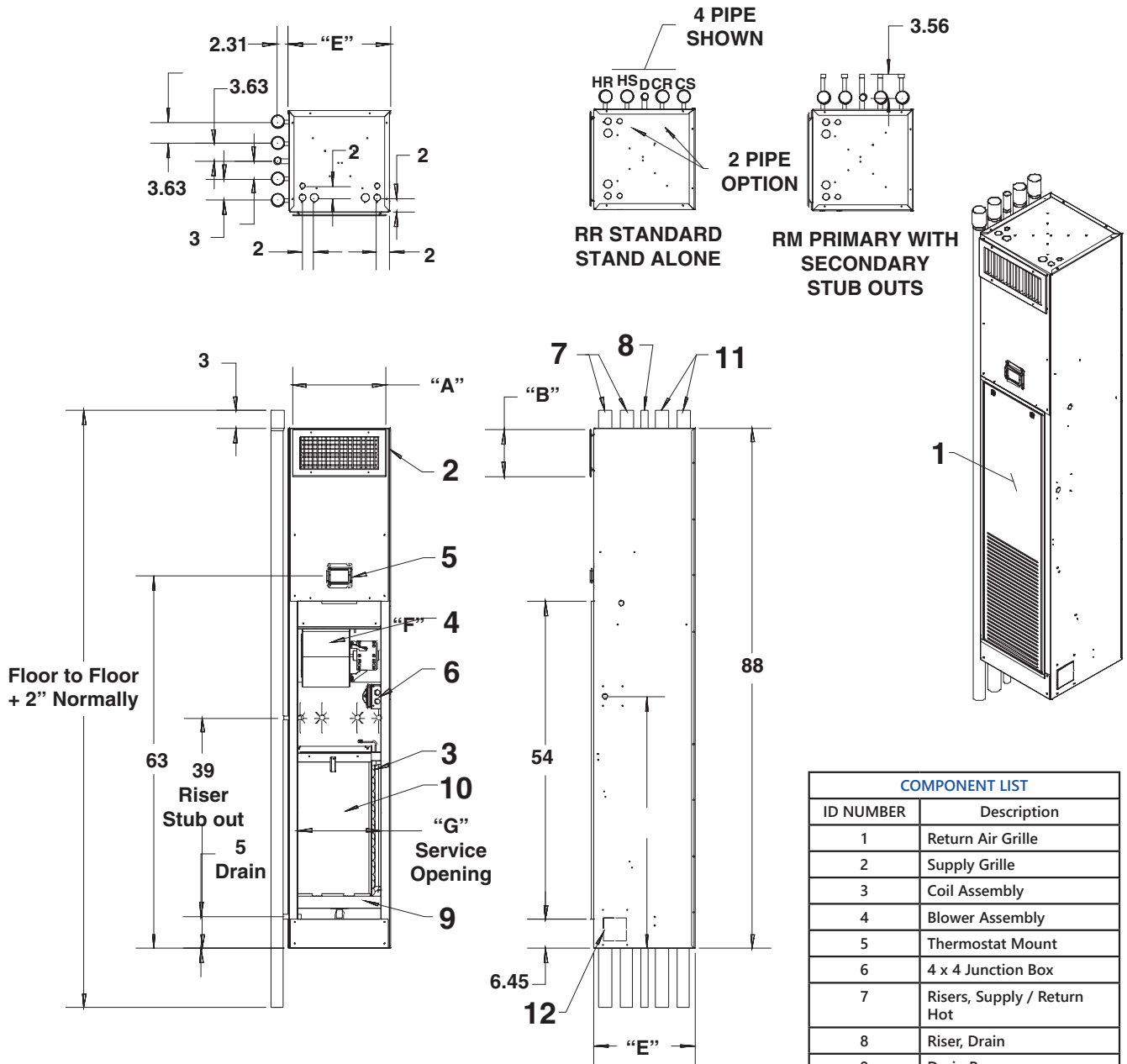

Floor to Floor + 2" Normally

63
39
Riser Stub out
5
Drain

"G"
Service Opening

COMPONENT LIST

ID NUMBER	Description
1	Return Air Grille
2	Supply Grille
3	Coil Assembly
4	Blower Assembly
5	Thermostat Mount
6	4 x 4 Junction Box
7	Risers, Supply / Return Hot
8	Riser, Drain
9	Drain Pan
10	Filter
11	Riser, Supply / Return Cold
12	Knockout for Optional Fresh Air Inlet

MODEL	SINGLE SUPPLY OPENING (1)			DOUBLE SUPPLY OPENING			TOP SUPPLY OPENING			E	F	G	FILTER SIZE
	A	B	SIZE	A	B	SIZE	C	D	SIZE				
3RR/RM	14	8	14 X 8							17	42.62	14.13	12.5 X 24.25 X 1
4RR/RM	14	12	14 X 12							17	42.62	14.13	12.5 X 24.25 X 1
6RR/RM	18	10	18 X 10							20	42.62	18.13	16.25 X 26.75 X 1
8RR/RM	18	12	18 X 12							20	42.62	18.13	16.25 X 26.75 X 1

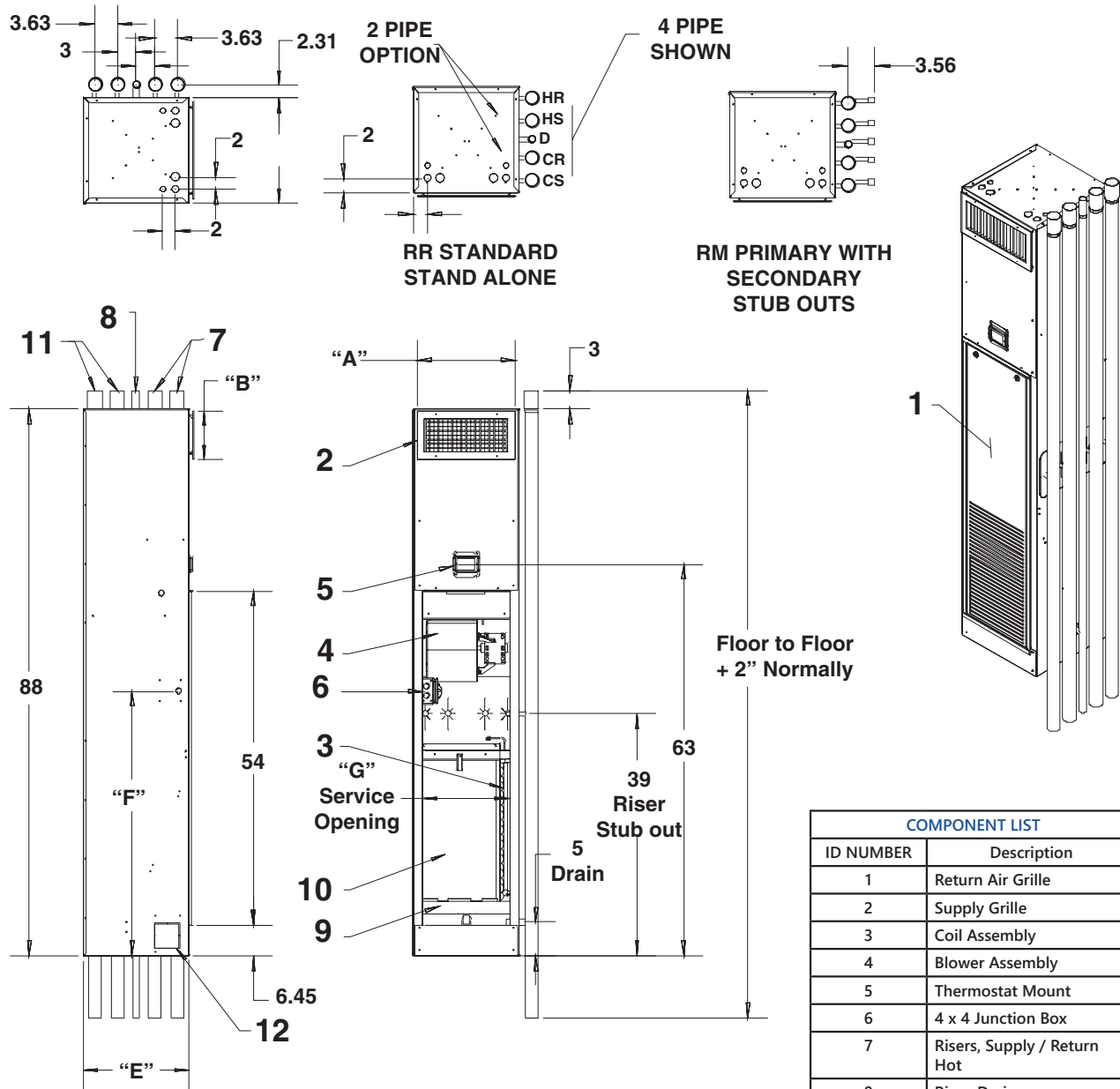

COMPONENT LIST	
ID NUMBER	Description
1	Return Air Grille
2	Supply Grille
3	Coil Assembly
4	Blower Assembly
5	Thermostat Mount
6	4 x 4 Junction Box
7	Risers, Supply / Return Hot
8	Riser, Drain
9	Drain Pan
10	Filter
11	Riser, Supply / Return Cold
12	Knockout for Optional Fresh Air Inlet

MODEL	SINGLE SUPPLY OPENING (1)			DOUBLE SUPPLY OPENING			TOP SUPPLY OPENING						
	A	B	SIZE	A	B	SIZE	C	D	SIZE	E	F	G	FILTER SIZE
3RR/RM	14	8	14 X 8							17	42.62	14.13	12.5 X 24.25 X 1
4RR/RM	14	12	14 X 12							17	42.62	14.13	12.5 X 24.25 X 1
6RR/RM	18	10	18 X 10							20	42.62	18.13	16.25 X 26.75 X 1
8RR/RM	18	12	18 X 12							20	42.62	18.13	16.25 X 26.75 X 1

Unit Arrangement

2 PIPE

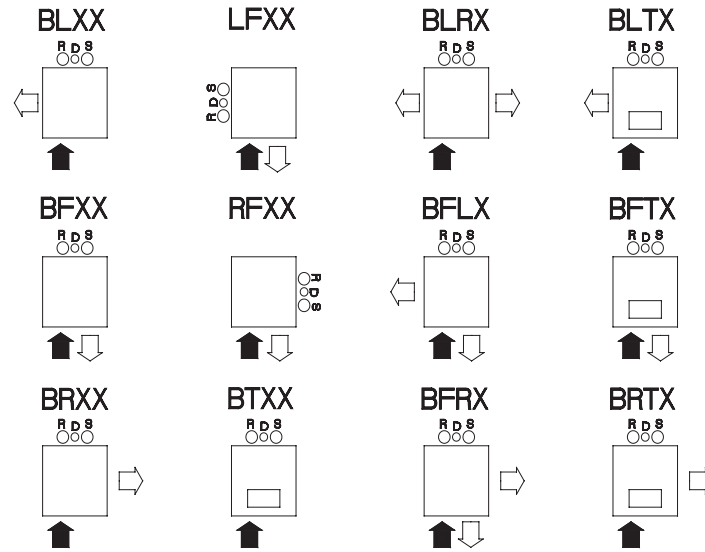

4 PIPE

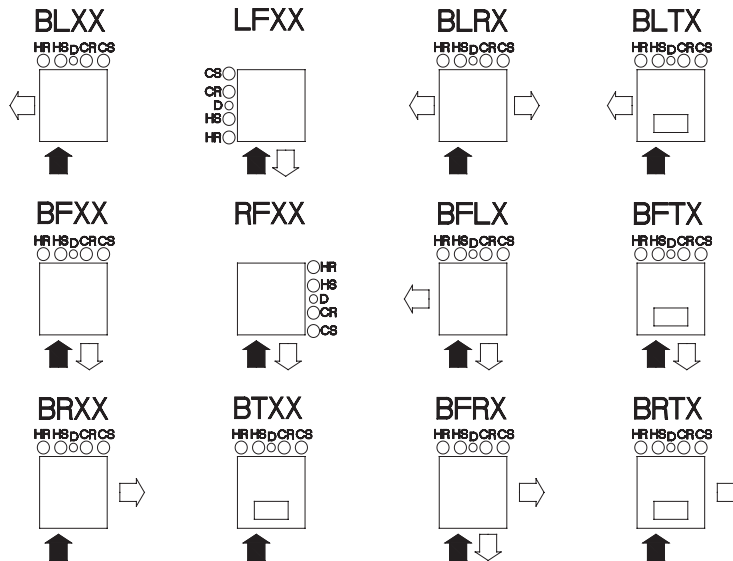

Legend:

→ Return

⇒ Supply

TYPICAL ARRANGEMENT



Risers one on the back

One supply grille is on the front

One supply grille is on the left

No fresh air inlet

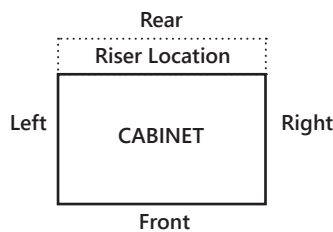

RETURN AIR GRILLE IS ALWAYS CONSIDERED THE FRONT OF UNIT

4-PIPE



HR = Hot Water Return
 HS = Hot water Supply
 D = Drain
 CR = Cold Water Return
 CS = Cold Water Supply

2-PIPE



R = Return
 D = Drain
 S = Supply

Blower Performance

RR, RM, RS								
CFM								
UNIT MODEL	FAN SPEED	EXTERNAL STATIC PRESSURE						
		0.0	0.05	0.1	0.15	0.2	0.25	0.3
3	HIGH	340	310	280	250	220	---	---
	MED	290	265	235	200	165	---	---
	LOW	275	245	230	190	160	---	---
4	HIGH	400	370	340	315	285	---	---
	MED	350	325	295	265	235	---	---
	LOW	275	250	225	195	165	---	---
6	HIGH	630	620	590	570	535	510	485
	MED	520	500	480	465	440	420	390
	LOW	430	420	390	370	340	325	300
8	HIGH	860	835	810	780	750	720	685
	MED	690	685	680	665	640	625	600
	LOW	550	545	540	535	530	520	510
10	MED HIGH	1021	1005	990	980	970	949	929
	MED LOW	846	832	817	804	790	776	762
	LOW	644	635	625	615	605	593	581
12	HIGH	1194	1177	1160	1138	1115	1092	1069
	MED LOW	988	971	954	937	920	905	891
	LOW	814	797	779	763	747	730	713

NOTES:
 Based on maximum of 5 rows.
 Deduct 10% for operation at 208V.

Data is subject to change. Please verify most current information on www.FirstCo.com or www.AE-Air.com websites.

Electric Heat Data

UNIT MODEL	NOM. CFM	kW			BTUH			FLA			MCA			MOCP		
		240V	208V	277V	240V	208V	277V	240V	208V	277V	240V	208V	277V	240V	208V	277V
3RR, RM, RS, ARC	300	0	0	0	0	0	0	0.6	0.6	0.35	1	1	1	15	15	15
		1	0.75	1	3400	2500	3400	4.8	4.2	4	6	5.5	5	15	15	15
		2	1.5	2	6800	5100	6800	8.9	7.8	7.6	12	10	10	15	15	15
		3	2.25	3	10200	7700	10200	13.1	11.4	11.2	17	15	14	20	15	15
4RR, RM, RS, ARC	400	0	0	0	0	0	0	0.6	0.6	0.5	1	1	1	15	15	15
		1	0.75	1	3400	2500	3400	4.8	4.2	4.1	6	5.5	6	15	15	15
		2	1.5	2	6800	5100	6800	8.9	7.8	7.7	12	10	10	15	15	15
		3	2.25	3	10200	7700	10200	13.1	11.4	11.3	17	15	15	20	15	15
6RR, RM, RS, ARC	600	0	0	0	0	0	0	0.5	0.5	0.7	1	1	1	15	15	15
		2	1.5	2	6800	5100	6800	8.8	7.7	7.9	12	10	10	15	15	15
		3	2.25	3	10200	7700	10200	13	11.3	11.5	17	15	15	20	15	15
		4	3	4	13600	10200	13600	17.2	14.9	15.1	22	19	19	25	20	20
8RR, RM, RS, ARC	800	0	0	0	0	0	0	1	1	0.9	2	2	2	15	15	15
		2	1.5	2	6800	5100	6800	9.3	8.2	8.1	12	10	11	15	15	15
		3	2.25	3	10200	7700	10200	13.5	11.8	11.7	17	15	15	20	15	15
		4	3	4	13600	10200	13600	17.7	15.4	15.3	23	20	20	25	20	20
10RR, RM, RS, ARC	1000	0	0	0	0	0	0	2.9	2.9	2.4	4	4	3	15	15	15
		3	2.25	3	10200	7700	10200	15.4	13.7	13.2	20	18	17	20	20	20
		4	3	4	13600	10200	13600	19.6	17.3	16.8	25	22	22	25	25	25
		5	3.75	5	17000	13000	17000	23.7	20.9	20.5	30	27	26	30	30	30
12RR, RM, RS, ARC	1200	0	0	0	0	0	0	2.9	2.9	2.4	4	4	3	15	15	15
		3	2.25	3	10200	7700	10200	15.4	13.7	13.2	20	18	17	20	20	20
		4	3	4	13600	10200	13600	19.6	17.3	16.8	25	22	22	25	25	25
		5	3.75	5	17000	13000	17000	23.7	20.9	20.5	30	27	26	30	30	30

MOTOR ELECTRICAL DATA (No Electric Heat)																
Voltage	Fan Speed	3RR					4RR					6RR				
		HP	Watts	Amps	MCA	MOCP	HP	Watts	Amps	MCA	MOCP	HP	Watts	Amps	MCA	MOCP
120/1/60	High	1/20	60	1.20	1.50	15	1/20	100	1.25	1.56	15	1/15	175	0.80	1.00	15
208/1/60	High	1/12	90	0.60	0.75	15	1/20	100	0.60	0.75	15	1/15	155	0.50	0.63	15
240/1/60	High	1/12	110	0.60	0.75	15	1/12	120	0.60	0.75	15	1/15	170	0.50	0.63	15
277/1/60	High	1/20	90	0.35	0.44	15	1/12	130	0.50	0.63	15	1/15	185	0.70	0.88	15
Voltage	Fan Speed	8RR					10RR					12RR				
		HP	Watts	Amps	MCA	MOCP	HP	Watts	Amps	MCA	MOCP	HP	Watts	Amps	MCA	MOCP
120/1/60	High	1/15	370	2.70	3.38	15	1/3	460	6.00	7.50	15	1/3	690	6.00	7.50	15
208/1/60	High	1/15	285	1.00	1.25	15	1/3	425	2.90	3.63	15	1/3	610	2.90	3.63	15
240/1/60	High	1/8	315	1.00	1.25	15	1/3	475	2.90	3.63	15	1/3	690	2.90	3.63	15
277/1/60	High	1/6	315	0.90	1.13	15	1/3	485	2.40	3.00	15	1/3	710	2.40	3.00	15

Data is subject to change. Please verify most current information on www.FirstCo.com or www.AE-Air.com websites.

Cooling Capacities

COOLING CAPACITY (1000 BTUH) (3 ROW and 3/1)																					
MODEL	NOMINAL CFM	GPM	P.D. (FT. WTR.)	75°F DB / 63°F WB									80°F DB / 67°F WB								
				40°F EWT			45°F EWT			50°F EWT			40°F EWT			45°F EWT			50°F EWT		
				TH	SH	TR	TH	SH	TR	TH	SH	TR	TH	SH	TR	TH	SH	TR	TH	SH	TR
03	300	1.5	2.6	10	7.7	13.2	8.2	6.9	10.9	6.5	6.1	8.6	11.9	8.5	15.8	10	7.8	13.3	8.2	7	10.9
		2.5	6.9	12	8.6	9.5	9.7	7.6	7.7	7.5	6.7	6	14.5	9.6	11.5	12.2	8.6	9.7	9.8	7.7	7.8
		3.5	13.1	13.2	9.2	7.5	10.6	8	6	8.1	6.9	4.6	16	10.3	9.1	13.4	9.1	7.6	10.7	8	6.1
04	400	1.5	2.6	11.3	9.3	14.9	9.4	8.5	12.4	7.6	7.4	10.1	13.4	10.3	17.7	11.3	9.4	15.1	9.4	8.6	12.5
		2.5	6.9	13.9	10.5	11	11.4	9.4	9	8.9	8.3	7.1	16.7	11.7	13.3	14	10.6	11.1	11.4	9.5	9.1
		3.5	13.1	15.5	11.3	8.8	12.6	10	7.2	9.7	8.7	5.5	18.8	12.6	10.6	15.7	11.3	8.9	12.6	10	7.2
06	600	2.5	3.3	15.1	13.1	12.1	13.2	12.3	10.5	11.5	11.5	9.3	19.8	14.9	15.8	17.2	14.0	13.8	14.6	13.0	11.7
		3.5	6.1	17.6	14.4	10.0	15.3	13.1	8.7	13.0	12.3	7.4	23.0	16.2	13.1	20.0	15.0	11.4	17.0	13.9	9.7
		4.5	9.7	19.3	14.7	8.6	16.8	13.7	7.4	14.2	12.7	6.3	25.2	17.0	11.2	21.9	15.7	9.8	18.7	14.5	8.3
08	800	4.0	7.8	20.8	17.6	10.4	18.1	16.5	9.0	15.5	15.5	7.7	27.2	20.0	13.6	23.7	18.8	11.8	20.1	17.5	10.1
		5.0	11.8	22.7	18.3	9.1	19.7	17.1	7.9	16.8	16.0	6.7	29.7	21.0	11.9	25.8	19.5	10.3	21.9	18.1	8.8
		6.0	16.5	24.0	18.8	8.0	20.9	17.6	7.0	17.7	16.4	5.9	31.4	21.7	10.5	27.3	20.1	9.1	23.2	18.6	7.7
10	1000	4.0	9.7	24.2	21.2	12.1	21.0	20.0	10.5	18.9	18.9	9.4	31.6	24.2	15.8	27.5	22.7	13.8	23.4	21.2	11.7
		5.0	14.7	26.7	22.2	10.7	23.2	20.9	9.3	19.7	19.5	7.9	34.9	25.2	14.0	30.4	23.8	12.2	25.8	22.1	10.3
		6.0	20.6	28.5	23.0	9.5	24.8	21.5	8.3	21.1	20.1	7.0	37.4	26.4	12.5	32.5	24.5	10.8	27.6	22.7	9.2
12	1200	4.0	9.7	26.2	24.3	13.1	23.1	23.1	11.5	21.8	21.8	10.9	34.3	27.6	17.2	29.8	25.9	14.9	25.4	24.4	12.7
		5.0	14.7	29.3	25.5	11.7	25.5	24.1	10.2	22.6	22.6	9.1	38.4	29.1	15.4	33.4	27.3	13.4	28.4	25.4	11.4
		6.0	20.6	31.6	26.4	10.6	27.5	24.8	9.2	23.4	23.2	7.8	41.4	30.3	13.8	36.0	28.2	12.0	30.6	26.2	10.0

COOLING CAPACITY (1000 BTUH) (4 ROW)																					
MODEL	NOMINAL CFM	GPM	P.D. (FT. WTR.)	75°F DB / 63°F WB									80°F DB / 67°F WB								
				40°F EWT			45°F EWT			50°F EWT			40°F EWT			45°F EWT			50°F EWT		
				TH	SH	TR	TH	SH	TR	TH	SH	TR	TH	SH	TR	TH	SH	TR	TH	SH	TR
03	300	1.5	2.1	9.3	7.3	12.5	8.2	6.9	10.9	6.9	6.4	9.2	12.2	8.4	16.4	10.7	7.9	14.2	9.1	7.3	12.1
		2.5	5.6	11.3	8.1	9.1	9.9	7.6	7.9	8.4	7.0	6.7	14.9	9.5	11.9	13.0	8.7	10.4	11.0	8.0	8.8
		3.5	10.8	12.5	8.6	7.2	10.9	8.0	6.2	9.3	7.2	5.3	16.4	10.1	9.4	14.3	9.3	8.2	12.1	8.4	6.9
04	400	1.5	2.1	10.4	8.9	13.8	9.1	8.4	12.0	7.9	7.9	10.5	13.6	10.2	18.1	11.8	9.5	15.7	10.1	8.9	13.4
		2.5	5.6	13.1	10.0	10.5	11.4	9.3	9.1	9.7	8.7	7.7	17.1	11.6	13.7	14.9	10.7	11.9	12.7	9.9	10.1
		3.5	10.8	14.7	10.7	8.4	12.7	10.0	7.3	10.8	9.1	6.2	19.2	12.4	11.0	16.7	11.4	9.5	14.2	10.4	8.1
06	600	2.5	3.6	16.8	13.9	13.4	14.6	13.0	11.7	12.4	12.2	9.9	22.0	15.9	17.6	19.1	14.8	15.3	16.3	13.8	13.0
		3.5	6.8	19.5	15.0	11.2	17.0	14.0	9.7	14.4	13.0	8.3	25.6	17.3	14.6	22.2	16.0	12.7	18.9	14.7	10.8
		4.5	10.8	21.4	15.8	9.5	18.6	14.6	8.3	15.8	13.5	7.0	28.1	18.3	12.5	24.4	16.9	10.8	20.7	15.4	9.2
08	800	3.0	5.1	20.6	17.8	13.7	17.9	16.8	12.0	15.7	15.7	10.5	27.0	20.3	18.0	23.5	19.0	15.7	20.0	17.7	13.3
		4.5	10.8	24.7	19.4	11.0	21.5	18.2	9.6	18.3	16.9	8.1	32.4	22.4	14.4	28.2	20.8	12.5	23.9	19.2	10.6
		6.0	18.4	27.2	20.4	9.1	23.7	19.0	7.9	20.1	17.6	6.7	35.7	23.7	11.9	31.0	21.9	10.3	26.4	20.0	8.8
10	1000	4.0	7.9	26.7	22.6	13.3	23.2	21.2	11.6	19.9	19.9	10.0	34.9	25.8	17.5	30.4	24.1	15.2	25.8	22.5	12.9
		5.5	14.0	30.7	24.2	11.2	26.7	22.6	9.7	22.7	21.1	8.3	40.2	27.9	14.6	35.0	25.9	12.7	29.7	23.9	10.8
		7.0	21.6	33.5	25.3	9.6	29.1	23.6	8.3	24.7	21.9	7.1	4.8	29.3	12.5	38.1	27.1	10.9	32.4	25.0	9.3
12	1200	4.5	9.7	29.7	26.2	13.2	25.9	24.7	11.5	23.2	23.2	10.3	38.9	29.9	17.3	33.9	28.0	15.1	28.8	26.1	12.8
		5.5	14.0	32.8	27.4	11.9	28.5	25.7	10.4	24.2	24.0	8.8	42.8	31.4	15.6	37.3	29.3	13.6	31.7	27.2	11.5
		6.5	18.9	35.1	28.3	10.8	30.5	26.5	9.4	25.9	24.7	8.0	45.9	32.5	14.1	40.0	30.3	12.3	34.0	28.0	10.5

COOLING CAPACITY (1000 BTUH) (3 ROW and 3/2)																					
MODEL	NOMINAL CFM	GPM	P.D. (FT. WTR.)	75°F DB / 63°F WB									80°F DB / 67°F WB								
				40°F EWT			45°F EWT			50°F EWT			40°F EWT			45°F EWT			50°F EWT		
				TH	SH	TR	TH	SH	TR	TH	SH	TR	TH	SH	TR	TH	SH	TR	TH	SH	TR
03	300	1.5	2.6	9.6	7.5	12.8	7.9	6.7	10.5	6.3	5.9	8.3	11.5	8.3	15.3	9.7	7.6	12.9	7.9	6.8	10.5
		2.5	7	11.6	8.4	9.2	9.4	7.4	7.4	7.2	6.5	5.7	14	9.4	11.1	11.7	8.4	9.3	9.4	7.4	7.5
		3.5	13.3	12.7	8.9	7.2	10.2	7.8	5.8	7.8	6.7	4.4	15.5	10	8.8	12.9	8.9	7.3	10.3	7.8	5.9
04	400	1.5	2.7	10.9	9.1	14.4	9	8.2	12	7.3	7.2	9.7	12.9	10	17.1	11	9.2	14.5	9.1	8.3	12.1
		2.5	7	13.4	10.2	10.6	10.9	9.1	8.7	8.5	8	6.8	16.1	11.3	12.8	13.5	10.3	10.7	10.9	9.2	8.7
		3.5	13.3	14.9	10.9	8.5	12.1	9.6	6.9	9.3	8.4	5.3	18.1	12.2	10.2	15.1	10.9	8.6	12.1	9.7	6.9
06	600	2.5	3.3	14.5	12.3	11.6	12.6	11.6	10.1	10.9	10.9	8.7	18.9	14.1	15.1	16.5	13.2	13.2	14.0	12.3	11.2
		3.5	6.1	16.8	13.3	9.6	14.6	12.4	8.4	12.4	11.6	7.1	22.0	15.2	12.6	19.2	14.2	10.9	16.3	13.1	9.3
		4.5	9.7	18.4	13.9	8.2	16.0	13.0	7.1	13.6	12.0	6.1	24.2	16.1	10.7	21.0	14.9	9.3	17.9	13.7	7.9
08	800	4.0	7.8	19.7	16.4	9.8	17.1	15.4	8.6	14.5	14.5	7.3	25.7	18.7	12.9	23.7	17.0	11.9	19.0	16.2	9.5
		5.0	11.8	21.4	17.1	8.6	18.6	16.0	7.5	15.8	14.9	6.3	28.1	19.6	11.2	25.9	17.8	10.4	20.7	16.8	8.3
		6.0	16.5	22.7	17.6	7.6	19.7	16.4	6.6	16.8	15.2	5.6	29.7	20.2	9.9	27.4	18.3	9.1	21.9	17.3	7.3
10	1000	4.0	9.7	22.9	19.9	11.4	19.9	18.7	9.9	17.6	17.6	8.8	30.0	22.6	15.0	26.1	21.2	13.0	22.1	19.8	11.1
		5.0	14.7	25.3	20.8	10.1	22.0	19.5	8.8	18.7	18.2	7.5	33.1	23.8	13.2	28.8	22.2	11.5	24.5	20.6	9.8
		6.0	20.6	27.0	21.5	9.0	23.5	20.1	7.8	20.0	18.7	6.7	35.4	24.7	11.8	30.8	22.9	10.3	26.1	21.2	8.7
12	1200	4.0	9.7	24.7	22.5	12.3	21.5	21.3	1.7	20.1	20.1	10.1	32.3	25.5	16.2	28.1	24.0	14.1	23.9	22.5	11.9
		5.0	14.7	27.7	23.7	11.1	24.1	22.3	9.6	20.9	20.9	8.4	36.2	26.9	14.5	31.5	25.2	12.6	26.8	23.5	10.7
		6.0	20.6	29.8	24.5	9.9	25.9	23.0	8.6	22.1	21.5	7.4	39.1	28.0	13.0	34.0	26.1	11.3	28.9	24.2	9.6

Data is subject to change. Please verify most current information on www.FirstCo.com or www.AE-Air.com websites.

Heating Capacities

HEATING CAPACITY (1000 BTUH) (3 ROW)							
MODEL	NOMINAL CFM	GPM	P.D. (FT. WTR.)	ENTERING WATER TEMPERATURE			
				180°F	160°F	140°F	120°F
03	300	1.0	1.1	25.5	20.8	16.2	11.5
		1.5	3.9	30.8	25.2	19.5	13.9
		2.0	8.4	32.6	26.7	20.7	14.7
04	400	1.0	1.1	29.4	24	18.6	13.2
		2.0	3.9	37.6	30.7	23.8	16.9
		3.0	8.4	40.7	33.3	25.8	18.4
06	600	3.0	4.6	56.3	46.1	35.8	25.6
		4.0	7.8	58.8	48.1	37.4	26.7
		5.0	11.8	60.5	49.5	38.5	27.5
08	800	4.0	7.8	72.0	58.9	45.8	32.7
		5.0	11.8	74.4	60.9	47.4	33.8
		6.0	16.5	76.2	62.3	48.5	34.6
10	1000	4.0	9.7	88.9	72.7	56.8	40.4
		5.0	14.7	92.3	75.5	58.7	42.0
		6.0	20.6	94.7	77.5	60.3	43.1
12	1200	4.0	9.7	100.2	82.0	63.7	45.6
		5.0	14.7	104.5	85.5	66.5	47.5
		6.0	20.6	107.6	88.0	68.4	48.9

HEATING CAPACITY (1000 BTUH) (3/1 ROW)							
MODEL	NOMINAL CFM	GPM	P.D. (FT. WTR.)	ENTERING WATER TEMPERATURE			
				180°F	160°F	140°F	120°F
03	300	1.0	1.4	17.7	14.5	11.2	8.0
		2.0	5.2	19.8	16.2	12.6	9.0
		3.0	11.1	20.5	16.8	13.1	9.3
04	400	1.0	1.4	19.1	15.7	12.2	8.7
		2.0	5.2	21.9	17.9	13.9	9.9
		3.0	11.1	22.9	18.7	14.6	10.4
06	600	1.0	2.1	26.4	21.6	16.8	12.0
		2.0	7.3	31.4	25.7	20.0	14.3
		3.0	15.2	33.2	27.2	21.2	15.1
08	800	1.0	2.1	28.2	23.1	18.0	12.8
		2.0	7.3	34.5	28.2	21.9	15.7
		3.0	15.2	37.0	30.3	23.6	16.8
10	1000	1.0	1.1	34.0	27.8	21.7	15.5
		2.0	5.4	42.3	34.6	26.9	19.2
		3.0	13.8	46.0	37.7	29.3	20.9
12	1200	1.5	2.8	40.8	33.4	26.0	18.5
		2.5	9.1	47.3	38.7	30.1	21.5
		3.4	19.6	50.4	41.2	32.1	22.9

HEATING CAPACITY (1000 BTUH) (4 ROW)							
MODEL	NOMINAL CFM	GPM	P.D. (FT. WTR.)	ENTERING WATER TEMPERATURE			
				180°F	160°F	140°F	120°F
03	300	2.0	3.6	32.0	26.2	20.4	14.5
		3.0	8.0	33.7	27.6	21.4	15.3
		4.0	17.3	34.7	28.6	22.1	15.8
04	400	2.0	3.6	40.4	33.0	25.7	18.3
		3.0	8.0	42.8	35.0	27.2	19.5
		4.0	14.0	44.2	36.2	28.2	20.1
06	600	3.0	5.1	60.5	49.5	38.5	27.5
		4.0	8.7	63.2	51.7	40.2	28.7
		5.0	13.1	65.0	53.2	41.4	29.6
08	800	4.0	8.7	79.2	64.8	50.4	36.0
		5.0	13.1	81.8	67.0	52.1	37.2
		6.0	18.4	83.7	68.5	53.3	38.1
10	1000	4.0	7.9	95.5	78.1	60.8	43.4
		5.0	11.8	99.2	81.2	63.1	45.1
		6.0	16.4	102.0	83.5	64.9	46.4
12	1200	4.0	7.9	108.8	89.1	69.3	49.5
		5.0	11.8	113.6	92.9	72.3	51.6
		6.0	16.4	117.1	95.8	74.5	53.2

HEATING CAPACITY (1000 BTUH) (4/1 ROW)							
MODEL	NOMINAL CFM	GPM	P.D. (FT. WTR.)	ENTERING WATER TEMPERATURE			
				180°F	160°F	140°F	120°F
03	300	1.0	1.4	16.0	13.1	10.2	7.3
		2.0	17.9	17.9	14.6	11.4	8.1
		3.0	11.1	18.5	15.2	11.8	8.4
04	400	1.0	1.4	17.3	14.2	11.0	7.9
		2.0	5.2	19.8	16.2	12.6	9.0
		3.0	11.1	20.7	16.9	13.2	9.4
06	600	1.0	2.1	23.9	19.6	15.2	10.9
		2.0	7.3	28.4	23.2	18.1	12.9
		3.0	15.2	30.1	24.6	19.2	13.7
08	800	1.0	2.1	25.6	20.9	16.3	11.6
		2.0	7.3	31.3	25.6	19.9	14.2
		3.0	15.2	33.6	27.5	21.4	15.3
10	1000	1.0	1.1	30.9	25.2	19.6	14.0
		2.0	5.4	38.4	31.4	24.4	17.4
		3.0	13.8	41.7	34.2	26.6	19.0
12	1200	1.5	2.8	37.0	30.3	23.6	16.8
		2.5	9.1	42.9	35.1	27.3	19.5
		3.5	19.6	45.7	37.4	29.1	20.8

HEATING CAPACITY (1000 BTUH) (3/2 ROW)							
MODEL	NOMINAL CFM	GPM	P.D. (FT. WTR.)	ENTERING WATER TEMPERATURE			
				180°F	160°F	140°F	120°F
03	300	1.0	0.8	21.9	17.8	13.8	9.8
		1.5	3.1	26.1	21.3	16.5	11.7
		2.0	6.7	27.8	22.7	17.6	12.5
04	400	1.0	0.8	25.2	20.5	15.8	11.2
		2.0	3.1	31.3	25.5	19.7	14
		3.0	6.7	33.9	27.6	21.4	15.2
06	600	1.0	0.7	27	21.9	16.9	11.9
		2.0	2.6	35.5	28.8	22.2	15.7
		3.0	5.6	39.5	32.1	24.8	17.5
08	800	1.0	0.7	29.3	23.7	18.3	12.9
		2.0	2.6	39.8	32.3	24.9	17.5
		3.0	5.6	45.1	36.6	28.2	19.9
10	1000	3.0	5.8	66.6	54.5	42.4	30.3
		4.0	10.3	70.4	57.6	44.8	32.0
		5.0	15.9	72.6	59.4	46.2	33.0
12	1200	3.0	5.8	73.7	60.3	46.9	33.5
		4.0	10.3	78.3	64.1	49.8	35.6
		5.0	15.9	81.2	66.4	51.7	36.9

Data is subject to change. Please verify most current information on www.FirstCo.com or www.AE-Air.com websites.

Supply Air Grilles

								TOP SUPPLY OPENING	
Standard 88" cabinet		Single discharge units are available with above grille sizes			Double discharge units are available with above grille sizes			Top single supply opening	
FRR Series									
UNIT SIZE	NOMINAL CFM	QTY	NOMINAL GRILLE SIZE	CORE AREA (SG. FT.)	QTY	NOMINAL GRILLE SIZE	CORE AREA (SQ. FT.)	QTY	NOMINAL GRILLE SIZE
3	300	1	14 X 8	0.65	2	14 X 6	1	1	14 X 10
4	400	1	14 X 12	1	2	14 X 6	1	1	14 X 10
6	600	1	18 X 10	1.13	2	18 X 6	1.3	1	16 X 12
8	800	1	18 X 12	1.37	2	18 X 6	1.3	1	16 X 12
10	1000	---	---	---	2	22 X 8	2.2	1	18 X 16
12	1200	---	---	---	2	22 X 8	2.2	1	18 X 16

Standard grille is a double deflection type with streamlined shaped roll-formed blades on 3/4" centers. 1 1/4" wide face border with a 1" overlap margin standard, furnished with countersunk screw holes. Rigid, roll-formed frames with reinforced mitered corners. Vertical and horizontal blades are friction pivoted and easily adjusted to provide desired spread or deflection. Blades maintain adjustable deflection setting during all conditions to velocity and pressure.

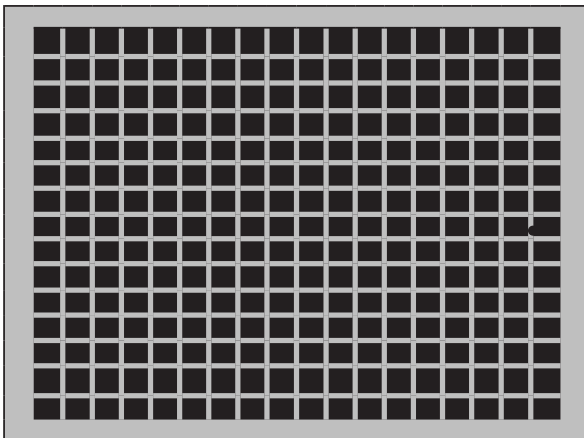

Standard grille finish is an appliance white baked enamel.

Access Panel / Return

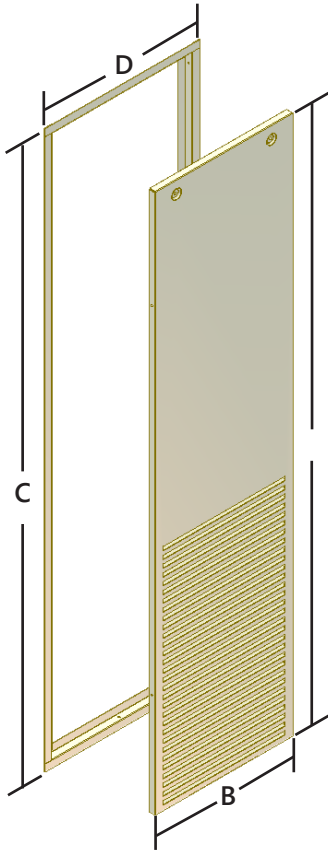

FLUSH MOUNT DIMENSIONS					
UNIT MODEL	PART NUMBER	A	B	C	D
03/04	9PWRF01	51-15/16	13-5/8	53-9/16	15-1/4
06/08	9PWRF02	51-15/16	17-5/8	53-9/16	19-1/4
10/12	9PWRF03	51-15/16	21-5/8	53-9/16	23-1/4

Access Panel Specification

- Optional panels include flush mount or frame type
- Constructed from 18 gauge galvanized steel and coated with white epoxy powder finish
- Panel is insulated with 1/2" heavy density fiberglass insulation
- Panel mounted with tamper-proof fasteners
- Intergral stamped steel return air louvers
- Panel provides access to all internal components
- Framed panels require field installation of frame

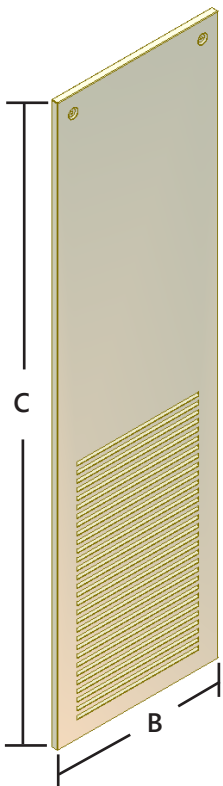

SURFACE MOUNT DIMENSIONS			
UNIT MODEL	PART NUMBER	A	B
03/04	9PWRS01	51-15/16	13-5/8
06/08		51-15/16	17-5/8
10/12		51-15/16	21-5/8

Exposed Cabinet Installa-

Exposed Cabinet Specification

- Clean, faster free exterior
- Exterior panels constructed from 18 gauge galvanized steel and coated with white epoxy powder finish
- Insulated steel Return Air/ Access Panel included with 1/4 turn tamper proof fasteners
- Flush stamped Return Air Louvers
- Rear pipe chase to facilitate hydronic and electric connections
- Optional aluminum single front discharge double deflection Supply Air Grille painted white (not applicable to top discharge units)

MODEL	TOP SUPPLY OPENING							
	C	D	SIZE	E	F	G	H	FILTER SIZE
3RR	14	10	14x10	22.20	18.00	17.00	14.13	12.5 X 24.25 X 1
4RR								
6RR	16	12	16x12	25.20	21.00	20.00	18.13	16.25 X 26.75 X 1
8RR								
10RR	18	16	18x16	29.20	25.00	24.00	22.13	20.50 X 29.25 X 1
12RR								

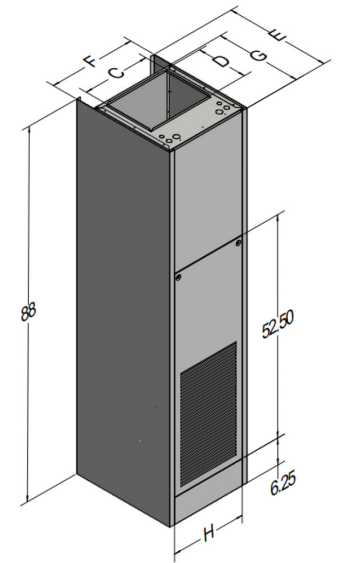

MODEL	SINGLE SUPPLY OPENING			DOUBLE SUPPLY OPENING (2)							
	A	B	SIZE	A	B	SIZE	E	F	G	H	FILTER SIZE
3RR	14	12	12X14	14	6	14X6	22.20	18.00	17.00	14.13	12.5 X 24.25 X 1
4RR											
6RR	18	12	18X12	18	6	18X6	25.20	21.00	20.00	18.13	16.25 X 26.75 X 1
8RR											
10RR	20	16	20x16	22	8	22X8	29.20	25.00	24.00	22.13	20.50 X 29.25 X 1
12RR											

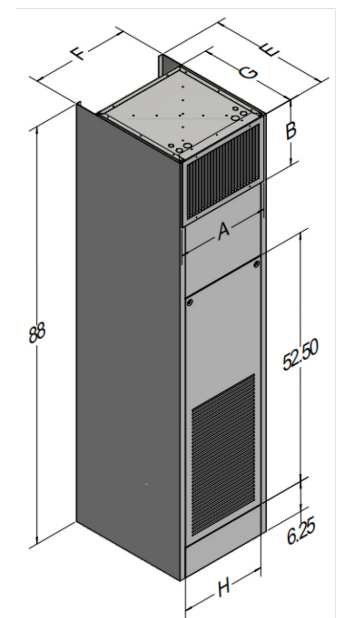

Nomenclature

Model Number Nomenclature

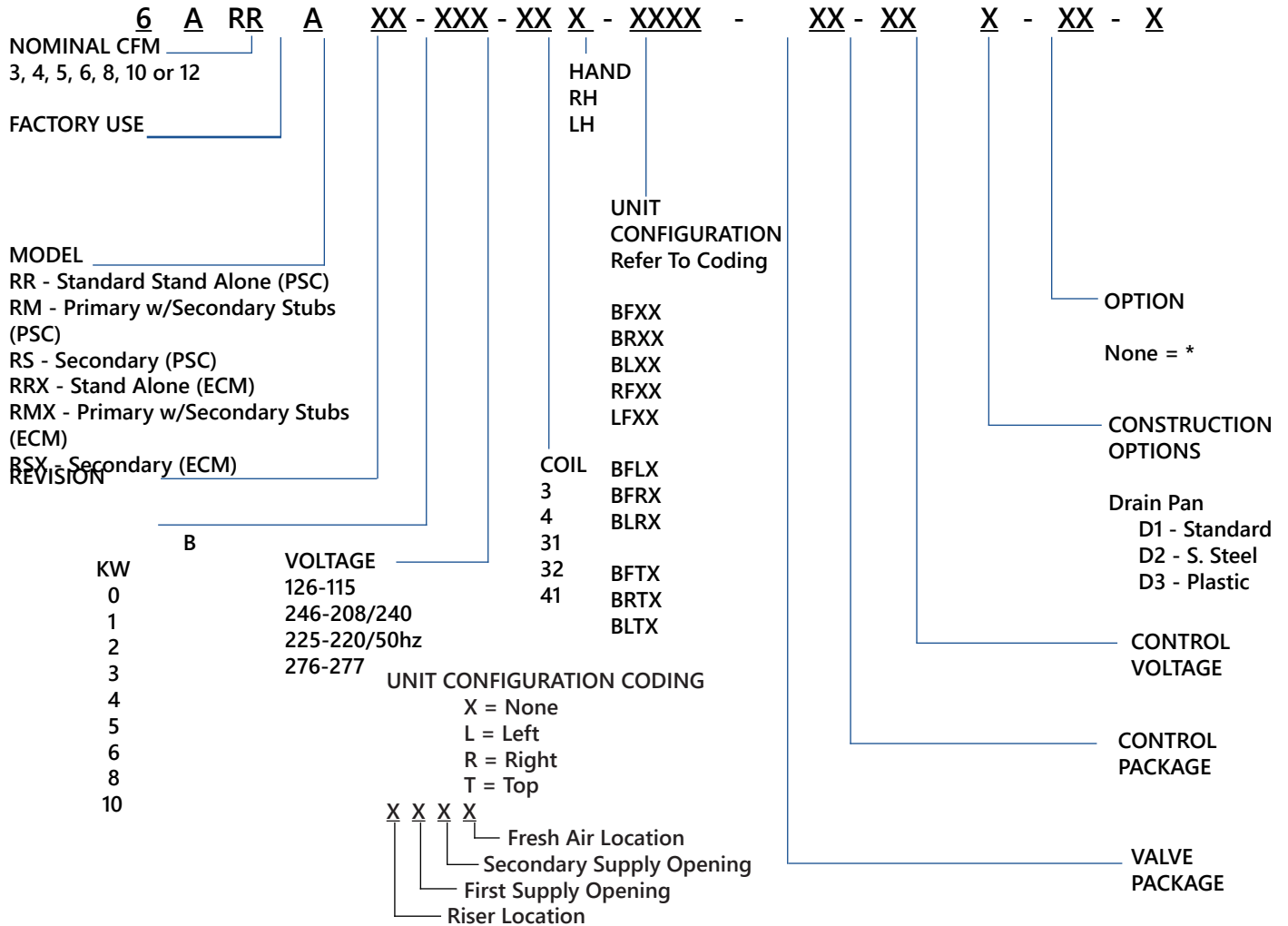

Guide Specifications

HVAC Guide Specifications — AR Fan Coil Unit — Vertical High Rise

Size Range:

300 to 1200 Nominal Cfm

Model Numbers:

RR (Furred-in) Stand Alone

RM (Furred-in, Primary with Secondary Stub outs)

RS Secondary Unit

Part 1 — General

1.01 SYSTEM DESCRIPTION

Stack fan coil units, 2-pipe, 4-pipe or electric heat for furred-in cabinets that are floor mounted in multi-story buildings.

1.02 QUALITY ASSURANCE

Units shall be tested in accordance with AHRI standard 440. All units shall be ETL approved. Each coil shall be factory tested for leakage at 300 psig air pressure with coil submerged in water. Insulation and adhesive shall meet NFPA-90A requirements for flame spread and smoke generation. All equipment wiring shall comply with NEC requirements.

1.03 DELIVERY, STORAGE AND HANDLING

Unit shall be handled and stored in accordance with the manufacturer's instructions.

Part 2 — Products

2.01 EQUIPMENT

A. General: Standard Features

Factory assembled, stack fan coil units. Units are complete with water coil, fan, motor, drain pan, and all required wiring, piping, controls, and special features.

B. Furred-In Stack Unit (RR):

The unit shall be constructed of 20-gage galvanized steel frame and 20-gage galvanized steel back panel.

The fan coil is open or enclosed for furred-in installation. These units are designed to have the wall-board

applied directly to the unit surface and all openings have standard 3/4-in. thick antimicrobial coated Tuf-skin RX fiberglass insulation. Units have double deflection aluminum discharge grille(s) and painted, stamped (standard) return-air grille panel. Removable return-air grille provides access to all internal piping and wiring.

Controls are provided with a quick disconnect plug for field-mounting on front of unit.

C. Back-To-Back Furred-In Stack Units (RS) Primary/Secondary:

The open unit shall be constructed of 20-gage galvanized steel frame and 20-gage galvanized steel back panel. These units are similar to the RR but are actually two completely separate units that share a

common set of risers. These units are designed to have the wallboard directly applied to the unit surface and openings have standard 1/2-in. drywall flanges. The interior surfaces shall be lined with 3/4-in. thick antimicrobial coated Tuf-skin RX fiberglass insulation. Units have double deflection aluminum supply grille(s) and painted, stamped return-air grille panel. Removable return-air grille provides access to all internal piping and wiring. Controls are provided with a quick disconnect plug for field-mounting on front of unit.

D. Drain Pan:

Removable drain pan shall be formed of heavy gauge galvanized steel and shall be coated inside with insulation. The drain is factory piped to the drain riser that has a removable

Guide Specifications

2. Fan wheel shall be double-width type with forward-curved blades and shall be statically and dynamically balanced.

3. Fan wheel and scroll shall be constructed of galvanized steel.

G. Coil:

1. Standard base unit shall be equipped with a 3-row for installation in a 2-pipe system. Additional coil depth and circuiting shall be provided for installation in a 4-pipe system as described in the Special Features section.

2. All coils shall have 1/2-in. copper tubes and aluminum fins spacing; coil fins are mechanically bonded to tube joints. The copper tubes comply with the ASTM B-75. The fin thickness is 0.06-in. and tube thickness is

0.016-inches. All coils are tested with air under water and are suitable for design working pressures of 300 psig.

3. Coil shall be equipped with a manual air vent and shall be piped to supply and return risers with valves as specified on the equipment drawings.

4. Piping between coil and risers shall compensate for maximum riser expansion and contraction of 11/2 inches.

H. Risers:

1. Standard factory-furnished and installed risers shall be 115-in. long with 3-in. belled ends at the top such that only one sweat connection shall be required at each floor to join one riser to another.

2. Risers shall be Type M copper insulated with 3/4-in. thick synthetic rubber.

3. Supply and return risers shall be as shown on equipment drawings, drain riser shall be 1 in. diameter.

I. Valves:

Optional factory furnished and installed piping shall include two ball valves and one 2-way motorized valve. The ball valves shall be rated at 150 psig.

J. Controls and Safeties:

1. Controls:

Standard controls for a 2-pipe system shall consist of a heating/cooling thermostat (SPDT) with 3-speed fan control.

2. Safeties:

Unit fan motor shall be equipped with integral motor protection.

K. Operating Characteristics:

1. A unit with a conventional coil, installed in a 2-pipe system, shall be capable of providing heating or cooling as determined by the operating mode of the central water supply system.

2. A unit with a row-split coil, installed in a 4-pipe system, shall be capable of providing sequenced heating and cooling.

L. Electrical Requirements

Standard unit shall operate on 115-v, single phase, 60-Hz electrical power supply.

M. Motor:

1. Fan motor shall be 3-speed, 115-v, single phase, 60-Hz, permanent split capacitor type, factory mounted on the blower housing.

2. Bearings shall be of the sealed sleeve type.

Guide Specifications

N. Add Options:

Certain standard features are not applicable when the features designated by * are specified.

Valve package standard options, 2-pipe or 4-pipe:

No Valves

2-ball valves on riser

2-way valves only (units without risers)

2-way valves and 2-ball valves

3-way valves only (units without risers)

3-way valves and 2-ball valves

3-way valves and 2-ball valves + Aqua Stat

2-Way Deluxe

2-Way valve, Auto-Flow setter, P/T Ports, Strainer, 2-ball valves

3-Way Deluxe

3-Way valve, Auto-Flow setter, P/T Ports, Strainer, 2-ball valves

* 1. Unit shall be equipped with a 4-row coil for installation in a 2-pipe system.

* 2. For installation in a 4-pipe system, unit shall be equipped with:

a. A 3/1, 3/2 or 4/1 row-split coil, as shown on equipment drawings for cooling and heating.

b. Two each supply and return risers as shown on equipment drawings and one 1 in. diameter drain riser.

c. Two ball valves, and two 2-way motorized valves.

d. Heating cooling thermostat with 3-speed fan controls.

* 3. Unit shall be equipped with 3-way motorized valves.

* 4. Supply and return risers shall be 3/4- in., 11/4- in., 2- in. or 2 1/2- in. diameter as shown on the equipment drawings.

* 5. Floor-to-floor height of risers shall be as specified on the equipment drawings.

* 6. Supply and return risers shall be Type L copper.

* 7. Insulation on risers shall be 3/4-in. thick synthetic rubber.

* 8. Unit shall be equipped with a separate reverse return riser with size as shown on the equipment drawings.

* 9. Motor shall be 3-speed, single phase, 60 Hz permanent split capacitor type for 208, 230 or 277 volts.

*10. Double-deflection steel supply grille(s) shall be finished with paint. Additional double-deflection supply grille(s) shall be furnished for field installation.

11. A fresh-air opening shall be provided as shown on the equipment drawings.

*12. 1-in. thick TA filters shall be installed in the filter track.

13. Unit shall be equipped with nichrome wire electric strip heaters for total or auxiliary electric heat as specified on the equipment schedule.

a. Heaters shall be protected by an automatic reset safety cutout switch.

b. Heater capacity shall be as specified on the equipment schedule.

c. Heaters shall be single phase, 60 Hz for 120, 208, 240 or 277 volts as specified on the equipment schedule.

*d. For total electric heat, unit controls may include a sequenced heating and cooling thermostat.

e. For auxiliary electric heat or twilight heat, unit controls shall include 2 additional automatic changeover devices.

14. Tamper-proof fasteners shall be installed on the access panels.

15. A plastic or stainless steel drain pan shall be available for factory installation.

16. Factory-installed installation options shall include antimicrobial coated, dual density fiberglass (Tuf-Skin Rx™) or foil faced fiberglass insulation.

17. Return Air Panels

a. Short surface mount.

b. Short flush mount (framed)