

MIXING BOXES

SHW / SHX / SVW / SVX

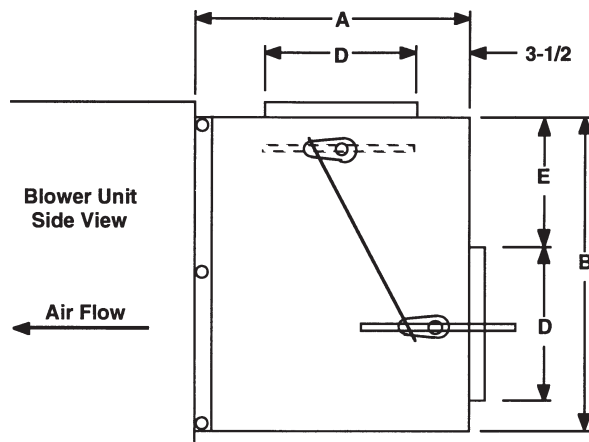

Mixing Box
Side View

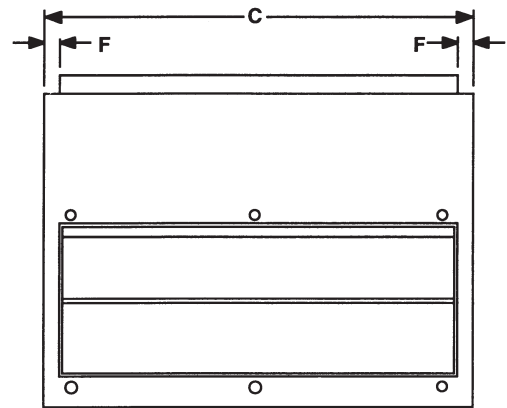

Mixing Box
Rear View

Dimensions:

MODEL	A	B	C	D	E	F	DAMPER SIZE (NOM)	SHIPPING WEIGHT
24MB	16	16-3/8	18-1/8	8	6	1-1/16	2- 16 x 8	40
36MB	16	16-3/8	27-5/8	8	6	1-1/16	2- 26 x 8	58
48MB	18	20-3/8	29-1/8	10	8	1-1/16	2- 27 x 10	65
60MB	18	20-3/8	36-1/8	10	8	1-1/16	2- 34 x 10	78
90MB	18	25-3/8	45-1/8	10	8	1-11/16	2- 42 x 10	110
120MB	20	30-3/8	48-1/8	12	10	1-1/16	2- 46 x 12	135
180MB	22	37-7/8	57-1/8	14	12	1-9/16	2- 54 x 14	190
240MB	22	50-1/2	57-1/8	14	24	1-9/16	2- 54 x 14	210

Features:

1. Cabinet fully insulated - 3/4 inch.
2. Attractive light gray epoxy finish on 24-60MB. Embossed galvanized cabinet on 90-240MB.
3. Crank arms and linkage rod for damper connection are furnished. Connections can be made on either side of mixing boxes. The balance of necessary linkage hardware, damper motor, and controls to be field supplied.
4. Dampers can be positioned for either rear/top or rear/bottom locations.
5. 1" duct flanges provided on damper openings.
6. Dampers have air seals on the edges for positive closing. 24-90MB have single horizontal damper blades. 120-240MB have double horizontal damper blades.
7. When used with water coils units, a "freezestat" must be installed to prevent coil damage caused by low ambient conditions.

Cat. No. CMB1203 (Replaces CMB1193)