

Installation, Operation, & Maintenance

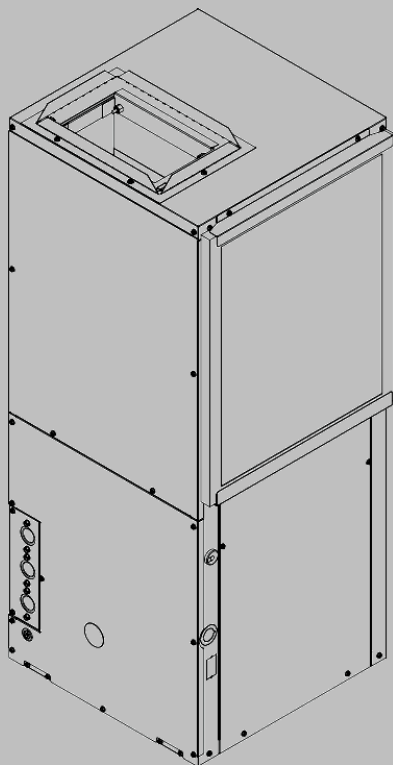

IOM 8301
Rev. A 04/21

WSS6 Series “Slim” Water Source Heat Pump 16 EER



HydroTechTM
R-410A Water Source Heat Pump



COPYRIGHT

First Co. works to continually improve its products and as a result, it reserves the right to change design and specifications without notice.

The warranty may be void unless the Startup & Performance Checklist [FIGURE 28 - Startup and Performance Checklist](#) is completed and returned to the warrantor. If the HVAC unit is not installed properly the warranty will be void as the manufacturer can't be held accountable for problems that stem from improper installation.

©2020 First Co., 8273 Moberly Lane, Dallas, TX 75227

*****WARNING TO INSTALLER, SERVICE PERSONNEL AND OWNER*****

Altering the product or replacing parts with non-authorized factory parts voids all warranty or implied warranty and may result in adverse operational performance and/or a possible hazardous safety condition to service personnel and occupants. Company employees and/or contractors are not authorized to waive this warning.

TABLE OF CONTENTS











<u>SAFETY CONSIDERATIONS</u>	4
<u>MODEL NOMENCLATURE</u>	5
<u>GENERAL INFORMATION</u>	6
<u>INTRODUCTION</u>	6
<u>STORAGE</u>	6
<u>UNIT DIMENSIONAL DATA</u>	7-8
<u>UNIT PHYSICAL DATA</u>	8
<u>ELECTRICAL DATA</u>	9
<u>UNIT INSPECTION CHECKLIST</u>	9
<u>INSTALLATION PRECAUTIONS</u>	10
<u>MOUNTING DETAILS</u>	11-12
<u>PIPING</u>	13
<u>CONDENSATE</u>	13-14
<u>DUCTWORK</u>	14
<u>ELECTRICAL</u>	15
<u>APPLICATION</u>	16-17
<u>CONTROLS</u>	18-22
<u>CONTROL BOX DETAIL</u>	23
<u>BLOWER SPEED CONTROL</u>	23
<u>REFRIGERATION SLIDE OUT DETAIL</u>	24-25
<u>PRE-STARTUP CHECKS</u>	26
<u>STARTUP INSTRUCTIONS</u>	26
<u>STARTUP & PERFORMANCE CHECKLIST INSTRUCTIONS</u>	26
<u>PERFORMANCE TABLES</u>	27
<u>WIRING DIAGRAMS</u>	28-31
<u>CIRCUIT SCHEMATIC</u>	32
<u>TROUBLESHOOTING</u>	33-34
<u>SUPPLEMENTAL DATA / TABLES</u>	35-37
<u>SUPPORT MATERIAL</u>	38
<u>PREVENTATIVE MAINTENANCE</u>	39
<u>STARTUP & PERFORMANCE CHECKLIST</u>	40
<u>INDEX OF FIGURES</u>	41
<u>INDEX OF TABLES</u>	42

SAFETY CONSIDERATIONS



1. **READ THE ENTIRE MANUAL BEFORE STARTING THE INSTALLATION.**
2. These instructions are intended as a general guide and do not supersede national, state, or local codes in any way.
3. Altering the product, improper installation, or the use of unauthorized factory parts voids all warranty or implied warranty and may result in adverse operation and/or performance or may result in hazardous conditions to service personnel and occupants. Company employees or contractors are not authorized to waive this warning.
4. This product should only be installed and serviced by a qualified, licensed, and factory authorized installer or service agency.
5. All “kits” and “accessories” used must be factory authorized when modifying this product. Refer and follow instructions packaged with the kits or accessories when installing.

RECOGNIZE THE FOLLOWING SAFETY NOTATIONS THROUGHOUT THIS MANUAL AND POSTED ON THE EQUIPMENT:

	WARNING	
Indicates a potentially hazardous situation or unsafe practices that could result in severe personal injury or death and/or damage to property.		
	WARNING	
	ELECTRIC SHOCK HAZARD	
This warning signifies potential electrical shock hazards that could result in personal injury or death.		
	CAUTION	
The CAUTION symbol indicates a potentially hazardous situation that may result in minor or moderate injury.		
	NOTE	
Used to highlight suggestions, which may result in enhanced installation, reliability or operation.		

MODEL NOMENCLATURE

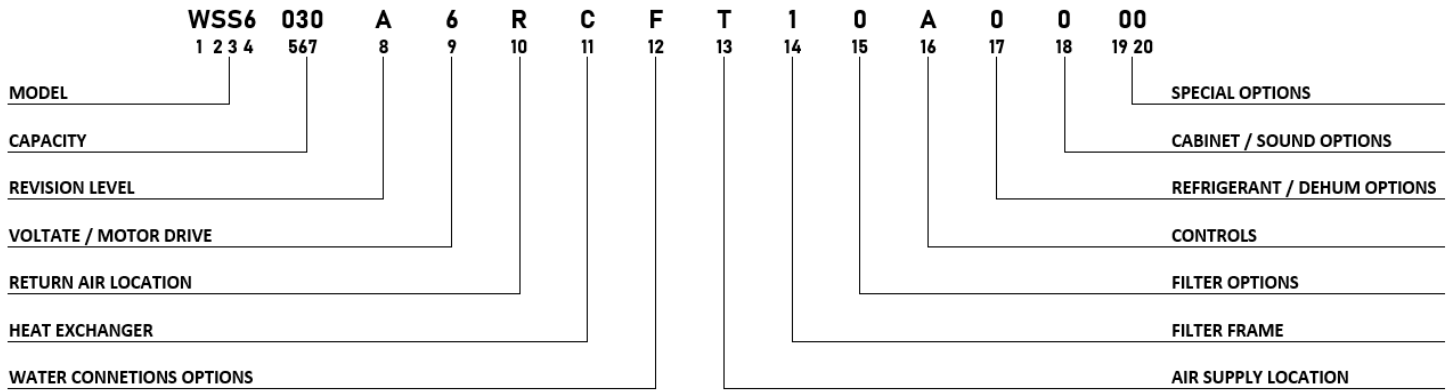

FIGURE 1 - WSS6 Model Nomenclature

MODEL NUMBER DESCRIPTION – WSS6 SERIES

Digits 1-4 – MODEL

WSS6 – 16 EER Slim WSHP

Digits 5-7 – CAPACITY

006 - 6,000 Btuh
 009 - 9,000 Btuh
 012 - 12,000 Btuh
 015 - 15,000 Btuh
 018 - 18,000 Btuh
 024 - 24,000 Btuh
 030 - 30,000 Btuh

Digit 8 – REVISION LEVEL

A –

Digit 9 – VOLTAGE / MOTOR DRIVE

6 – 208-230/1/60
 7 – 265/1/60

Digit 10 – RETURN AIR LOCATION

L – Left Hand
 R – Right Hand

Digit 11 – Heat Exchanger

C – Copper
 N – Cupronickel

Digit 12 – WATER CONNECTION OPTIONS

F – Front

Digit 13 – AIR SUPPLY LOCATION

T – Top (Vertical)

Digit 14 – FILTER FRAME

1 – 1" Frame
 2 – 2" Frame

Digit 15 – FILTER OPTIONS

0 – 1" TA Std
 A – 2" MERV 8
 B – 2" MERV 11

Digit 16 – CONTROLS

A – Std

Digit 17 – REFRIGERANT / DEHUM OPTIONS

0 – NONE

Digit 18 – CABINET / SOUND OPTIONS

0 – Std Insulation

Digits 19-20 – SPECIAL OPTIONS

00 – No Options

GENERAL INFORMATION



CAUTION

DO NOT use these units as a source of heating or cooling during the construction process. Mechanical components and filters can become clogged with dirt and debris, which can cause damage to the system.

The manufacture does not warrant equipment subjected to abuse. Construction debris can void warranties and liability for equipment failure, personal injury, and property damage.

Extreme caution must be taken that no internal damage will result from screws that are drilled into the cabinet.



INTRODUCTION



The Hydrotech WSS6 model water to air heat pumps provide the best combination of performance, efficiency and reliability in a compact form factor. The heat pump comes standard with ECM blowers for high efficiency and comfort and features a removable condensing section design to allow for easy servicing of the unit.

All WSS6 models are certified to AHRI ISO Standard 13256-1. The WSS6 models are designed to operate with fluid temperatures between 50°F to 110°F in cooling mode and 50°F to 90°F in heating mode for continuous operation.

STORAGE

Equipment should be stored in a clean dry, conditioned area with maximum temperatures up to 120°F and minimum temperatures to 32°F. Units should be stored upright and in an indoor environment. It is recommended to leave packaging on the unit until the installation is to begin.

 **WARNING** 



 **ELECTRIC SHOCK HAZARD** 

Before servicing equipment, ALWAYS turn off all power to the unit. There may be more than one disconnect switch. Electrical shock can cause injury or death.

Clear surrounding area of all tools, equipment, and debris before operating this unit.



Unit must never be operated under any circumstances without an air filter in place.

These instructions are given for the installation of the WSS6 Water source heat pump specifically. For any other related equipment, refer to the appropriate manufacturer’s instructions.

 **NOTE** 

Material in this shipment has been inspected at the factory and released to the transportation agency in good condition. When received, a visual inspection of all cartons should be made immediately. Any evidence of rough handling or apparent damage should be noted on the delivery receipt in the presence of the carrier’s representative. If damage is found, a claim should be immediately filed against the carrier.

These models are designed for indoor installation only. Installation of this equipment, wiring, ducts, and any related components must conform to current agency codes, state laws, and local codes. Such regulations take precedence over general instructions contained in this manual.

 **CAUTION** 

Stacking of the WSS6 systems is strictly prohibitive. Failure to do so may result in system and/or property damage.

DO NOT use these units as a source of heating or cooling during the construction process. Mechanical components and filters could become clogged with dirt and debris, which can cause damage to the system.

The manufacture does not warrant equipment subjected to abuse. Construction debris can void warranties and liability for equipment failure, personal injury, and property damage.

 **CAUTION** 

UNIT DIMENSIONAL DATA

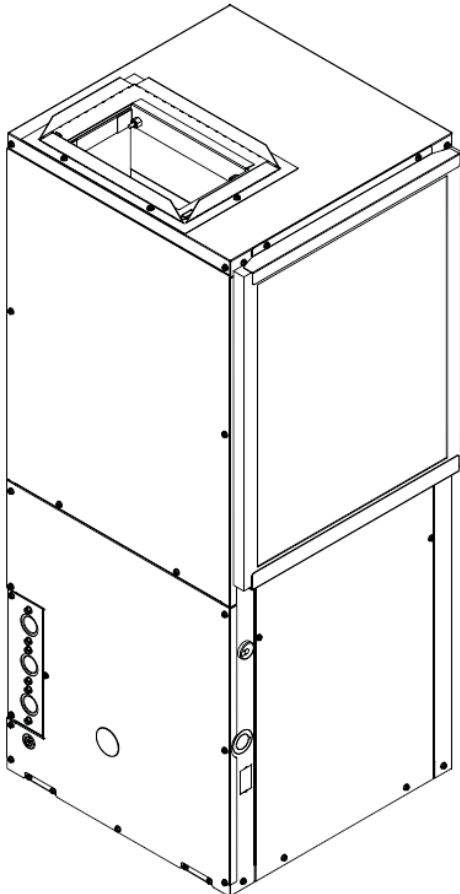

FIGURE 2 - Dimensional Drawing

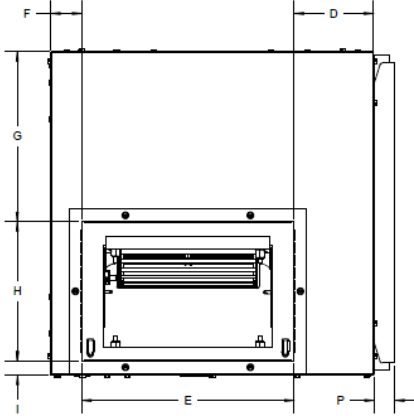

FIGURE 3 - Right Top View

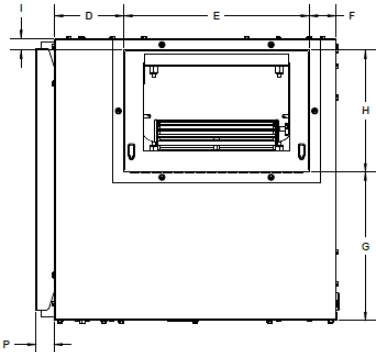

FIGURE 4 - Left Top View

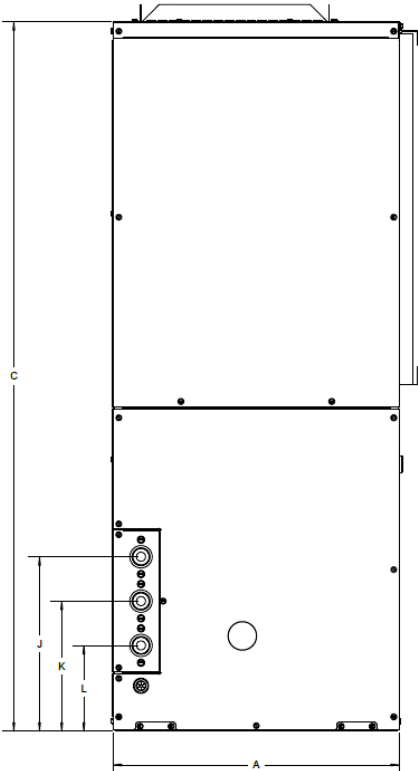

FIGURE 5 - Front View

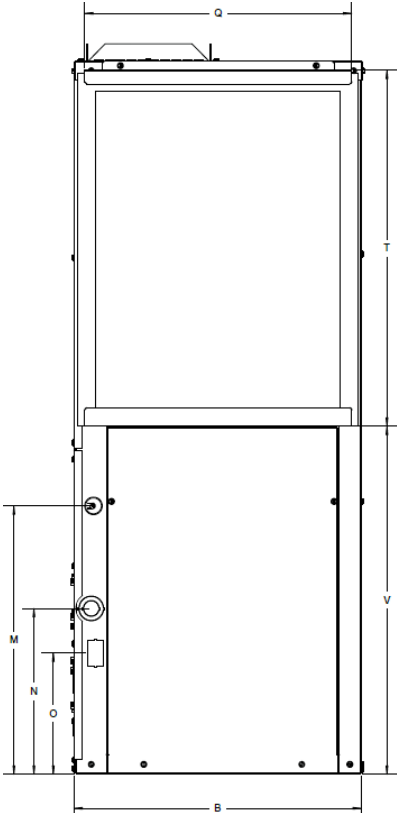

FIGURE 6 - Return View

UNIT DIMENSIONAL DATA CONTINUED

UNIT DIMENSIONAL DATA												
Model	A	B	C	D	E	F	G	H	I	J	K	L
	Overall Cabinet			Supply Connections						Water Connections		
WSS6006	16.1	16.1	40	3.3	10.6	1.5	8.5	7.0	0.6	9.8	7.3	4.8
WSS6009	16.1	16.1	40	3.3	10.6	1.5	8.5	7.0	0.6	9.8	7.3	4.8
WSS6012	16.1	16.1	40	3.3	10.6	1.5	8.5	7.0	0.6	9.8	7.3	4.8
WSS6015	16.1	16.1	40	3.3	10.6	1.5	8.5	7.0	0.6	9.8	7.3	4.8
WSS6018	18.1	18.1	40	5.9	13.0	1.5	4.4	10.6	0.6	9.8	7.3	4.8
WSS6024	18.1	18.1	40	5.9	13.0	1.5	4.4	10.6	0.6	9.8	7.3	4.8
WSS6030	18.1	18.1	40	5.9	13.0	1.5	4.4	10.6	0.6	9.8	7.3	4.8

Table 1 – Unit Dimensional Data

UNIT DIMENSIONAL DATA CONTINUED							
Model	M	N	O	P	Q	T	V
	Electrical Connections			Return Connections			
WSS6006	15.0	9.3	6.8	1.0	15.0	20.0	19.5
WSS6009	15.0	9.3	6.8	1.0	15.0	20.0	19.5
WSS6012	15.0	9.3	6.8	1.0	15.0	20.0	19.5
WSS6015	15.0	9.3	6.8	1.0	15.0	20.0	19.5
WSS6018	15.0	9.3	6.8	1.0	17.0	20.0	19.5
WSS6024	15.0	9.3	6.8	1.0	17.0	20.0	19.5
WSS6030	15.0	9.3	6.8	1.0	17.0	20.0	19.5

Table 2 – Unit Dimensional Data Continued

UNIT PHYSICAL DATA

UNIT PHYSICAL DATA							
WSS6	006	009	012	015	018	024	030
Compressor (Quantity)	Rotary (1)	Rotary (1)	Rotary (1)	Rotary (1)	Scroll (1)	Scroll (1)	Scroll (1)
Factory Charge (R410A) lbs [oz]	1.95 [31.2]	1.95 [31.2]	2.03 [32.5]	2.03 [32.5]	3.25 [51.2]	3.25 [51.2]	3.3 [56]
Fan Motor							
Motor (Quantity)	1	1	1	1	1	1	1
Fan Motor Type	ECM	ECM	ECM	ECM	ECM	ECM	ECM
Motor HP Standard / High Static	1/4	1/4	1/4	1/4	1/2	1/2	1/2
Blower							
Blowers (Quantity)	1	1	1	1	1	1	1
Blower Wheel Size (D x W)	9x7	9x7	9x7	9x7	10x7	10x7	10x7
Water Connect							
Size FPT (in)	3/4	3/4	3/4	3/4	3/4	3/4	3/4
Condensate Connection							
Size FPT (in)	3/4	3/4	3/4	3/4	3/4	3/4	3/4
Air Coil							
Dimensions (H x W)	20 x 12	20 x 12	20 x 12	20 x 12	20 x 14	20 x 14	20 x 14
Face Area (ft ²)	1.7	1.7	1.7	1.7	1.9	1.9	1.9
Miscellaneous							
Throwaway Filter (Dimensions)	20x16	20x16	20x16	20x16	20x18	20x18	20x18
Throwaway Filter (Quantity)	1	1	1	1	1	1	1
Weight – Operating (lbs)	153	155	157	159	211	213	215
Weight – Packaged (lbs)	158	160	162	164	216	218	220
Notes: FPT = Female Pipe Thread							

Table 3 – Unit Physical Data

ELECTRICAL DATA

ELECTRICAL DATA									
MODEL NUMBER	VOLTAGE-PH-HZ	COMPRESSOR		BLOWER		MIN. CIRCUIT AMPACITY	MAX. CIRCUIT PROTECTION	MIN. VOLTAGE	MAX. VOLTAGE
		RLA	LRA	FLA	HP				
WSS6006	208/230V-1-60	3	15	2.3	1/4	7	15	187	253
	265V-1-60	2.7	11	2.3	1/4	6	15	238	292
WSS6009	208/230V-1-60	4.4	22	2.3	1/4	8	15	187	253
	265V-1-60	3.5	22	2.3	1/4	7	15	238	292
WSS6012	208/230V-1-60	4.7	26	2.3	1/4	9	15	187	253
	265V-1-60	3.8	23	2.3	1/4	8	15	238	292
WSS6015	208/230V-1-60	6.3	32	2.3	1/4	11	15	187	253
	265V-1-60	5.6	27	2.3	1/4	10	15	238	292
WSS6018	208/230V-1-60	9	47.5	4.1	1/2	16	20	187	253
	265V-1-60	7.1	43	4.1	1/2	13	15	238	292
WSS6024	208/230V-1-60	10.9	62.9	4.1	1/2	18	20	187	253
	265V-1-60	9	54	4.1	1/2	16	20	238	292
WSS6030	208/230V-1-60	12.8	72.2	4.1	1/2	21	25	187	253
	265V-1-60	11.2	60	4.1	1/2	19	20	238	292

Table 4 - Electrical Data

UNIT INSPECTION CHECKLIST

Before preparing unit for installation, completing the inspection procedures below.

- 1) Visually inspect unit for any shipping damage. Damage must be reported immediately to the shipping company to make a claim.
- 2) Ensure that the carrier make proper notation of any shortages or damage on all copies of the freight bill and completes a common carrier inspection report.
- 3) Verify that unit nameplates on the data label match the sales order or bill of lading (including, unit configuration, size and voltage).
- 4) Immediately before installation, remove unit front panel and verify that all electrical connections are tight and that there are no loose wires.
- 5) Check to make sure that the refrigerant piping is free from any kinks and there is no interference between unit piping and sheet metal or electrical wires.
- 6) Remove the blower access panel and remove the Styrofoam packaging mount underneath the blower.
- 7) Check that the blower spins freely within the housing and there are no obstructions between the wheel and housing. The wheel can sometimes come loose in shipping.
- 8) Ensure that evaporator distributor tubes are not touching one in another and that they are over the drain pan.
- 9) Check the condensate sensor on the drain pan to make sure that it is rigid and attached.

- 10) Check the air-coil fins for any damage during shipping.
- 11) Ensure that shipping screws are removed from condensing section. Refer to **FIGURE 7 - Removal of Shipping Screws** for more information.

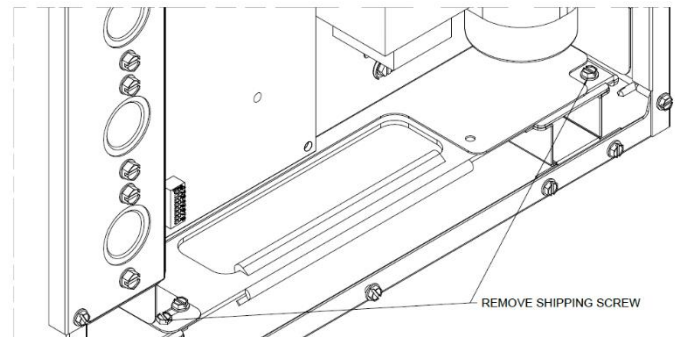

FIGURE 7 - Removal of Shipping Screws



NOTE



Check the unit nameplate for correct voltage with the plans before installing the equipment. Also make sure all electrical ground, connections are made in accordance with local code.

INSTALLATION PRECAUTIONS



WARNING



Use multiple people when moving and installing these units. Failure to do so could result in injury or death.



CAUTION



Contact with metal edges and corners can result injury. Protective gloves should be worn when handling. Exercise caution when installing and servicing unit.

Observe the following precautions for typical installation:

- Always use proper tools and equipment
- No wiring or any work should be attempted without first ensuring the unit is completely disconnected from the power source and locked out. Also, verify that a proper permanent and uninterrupted, ground connection exists prior to energizing power to the unit.
- Review unit nameplate and wiring diagram for proper voltage and control configurations. This information may vary from unit to unit.



CAUTION



When the unit is in operation components are rotating at high speeds and caution should be taken.



WARNING



When soldering and brazing, it is recommended to have a fire extinguisher readily available. When soldering and brazing close to valves or sensitive components, heat shields or wet rags are required to prevent damage to the valves or components.



NOTE



Insulation is installed in the unit to provide a barrier between varying atmospheres outside and within the unit. If insulation is damaged condensation can occur and can lead to corrosion, component failure, and possible property damage. Damaged insulation must be repaired prior to the operation of the unit. Insulation will lose its effectiveness and value when wet, torn, separated, and/or damaged.



CAUTION



Always wear all appropriate personal protection Equipment when installing and servicing these units.



CAUTION



When servicing this equipment, because of high pressures, make sure the reversing valve, expansion device, filter drier and other components are specifically designed for R-410A refrigerant.

ONLY USE service equipment specifically designated for use with R-410A.



WARNING



R-410A can become combustible if mixed with air at elevated temperature and/or pressure. Failure to follow this warning could result in property damage and personal injury or death.

MOUNTING DETAILS



NOTE



It is important to ensure the unit is securely mounted and that the mounting structure is sufficient to support the operating weight of the equipment. Place and size all anchors to ensure a safe and durable installation.

Locate the unit in an area that provides minimum clearance to all service access panels. [FIGURE 2 - Dimensional Drawing](#) and [Table 1 – Unit Dimensional Data](#) & [Table 2 – Unit Dimensional Data Continued](#) for detailed information on unit dimensional sizes. Consider all additional clearances needed for water connections, electrical connections, duct connections and sufficient return airflow.

These units are for indoor installation ONLY!

Do not locate unit in areas subject to freezing temperatures or where high humidity levels could cause cabinet condensation. WSS6 units are available in right and left hand configurations. Units should be mounted level with a proper drain pan pitch toward the condensate drain as seen below in [FIGURE 8 - Mounting Illustration](#). 3/8"-1/2" vibration isolation pads must be used to minimize vibration transmission.

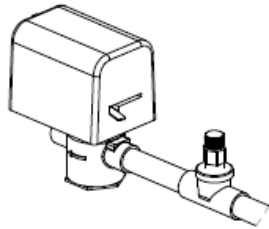

SLOW CLOSING
24VAC WATER VALVE
(FOR WELL WATER SYSTEM)

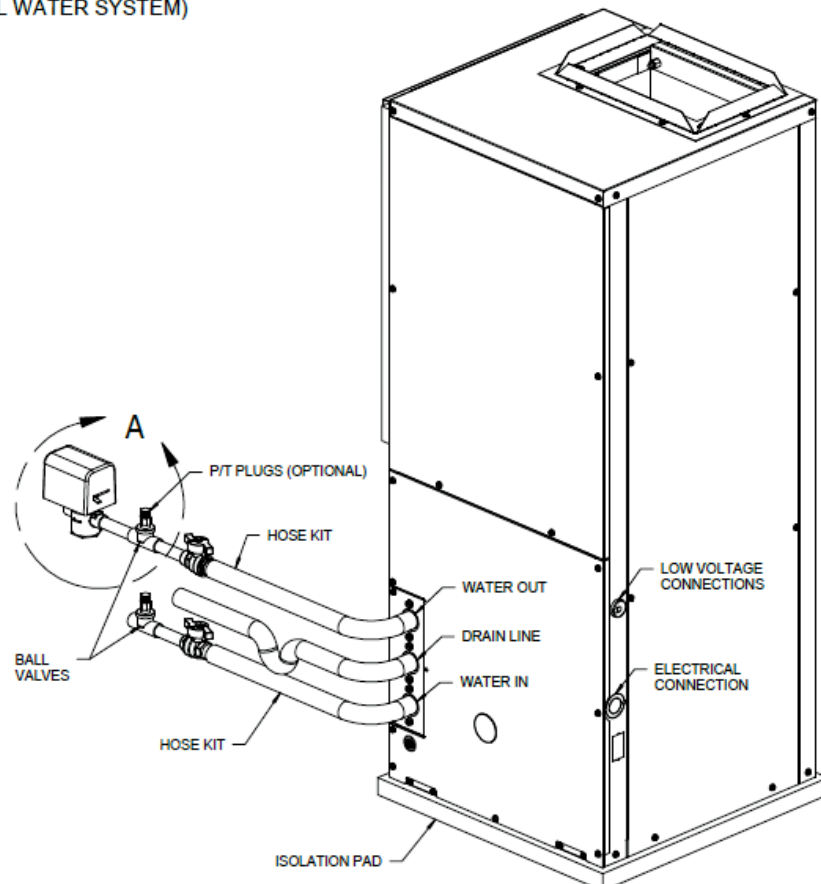

FIGURE 8 - Mounting Illustration

MOUNTING DETAILS CONTINUED

MOUNTING EXAMPLES

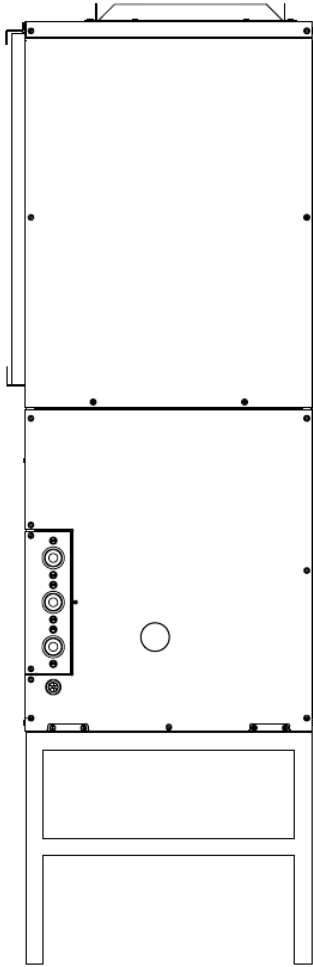

FIGURE 9 - Mount on High Platform

Units should be mounted level on a solid platform no less than $\frac{3}{4}$ " plywood or other related material with a proper drain pan pitch toward the condensate drain.

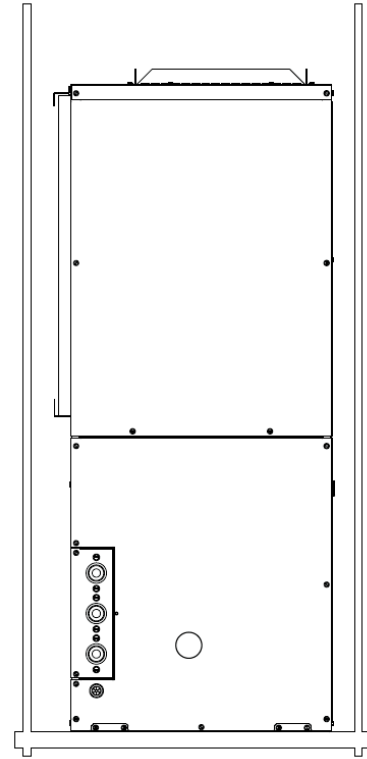

FIGURE 10 - Hanging from Ceiling

PIPING



CAUTION



Prior to making piping connections, contractor must clean and flush water loop system. Failure to clean/flush system may result in nuisance tripping and premature component failure.

PIPING NOTES

1. Flush all field piping prior to connection to clear all debris.
2. Open all valves (mid-way for hand valves, manually open motorized valves) prior to soldering and brazing. Use proper heat shields to protect valve bodies.
3. When soldering or brazing to the unit, it is recommended to have a fire extinguisher readily available.
4. Use proper soldering and brazing techniques to protect valve bodies and unit components.
5. Avoid rapid quenching of soldered joints to prevent weakening.
6. Make provisions for expansion and contraction of piping systems to provide movement with temperature changes. Failure to do so will result in damage and failure of piping, fittings, and valves throughout the system.
7. DO NOT insulate the heads or motorized portion of control valves. Excessive heat build-up can cause damage and affect proper operation of the system.
8. Consider electrical routing when installing field piping.
9. Observe all regulations and codes governing installation of piping.
10. When all connections are complete, pressure test the system, and repair any leaks or faulty joints. Hydronic systems are not designed to hold pressurized air and should only be tested with water. Failure to observe this note could damage the system.

PIPING INSTALLATION:

All piping must be adequately sized to meet the designed water flow as specified for the specific application, and must adhere to all applicable codes. Piping connections on the equipment are not necessarily indicative of the proper supply and return line sizes. Refer to the project drawings and specifications for sizing.

On units with plastic drain pans the drain connection must be made hand tight only.

Chilled water piping must be properly insulated to prevent condensation and potential property damage. It is also recommended that all piping be insulated to prevent freezing in unconditioned spaces.



CAUTION



Do not bend or kink supply lines or hoses. For all supply lines or hoses of 1-1/2" OD or greater, use proper sized fitting is recommended to prevent piping damage and potential restrictions in water flow.



NOTE



For all applications, 50°F minimum entering water temperature and rated water flow is required to prevent freezing. Antifreeze solution is required for any application with entering water below 50°F. Frozen water coils are not covered under warranty.

These units are designed to operate with the entering liquid temperature between 50°F and 100°F. Below 50°F. Antifreeze solution must be used to prevent freezing. Frozen water coils are not covered under warranty.

CONDENSATE

Condensate drain lines must be properly installed with adequate slope away from unit to ensure proper drainage. A minimum trap of 1.5 inches must be installed to isolate the negative pressures of the drain pan from the drain line. Refer to [FIGURE 11 - Condensate Drain Layout](#) for schematic information on the condensate drain lines.



CAUTION



Check the condensate overflow sensor for proper operation and adjust if necessary. Final field adjustments ensures proper operation to avoid property damage.



CAUTION



On units with plastic drain pans, the drain connection must be made hand tight only.

CONDENSATE CONTINUED

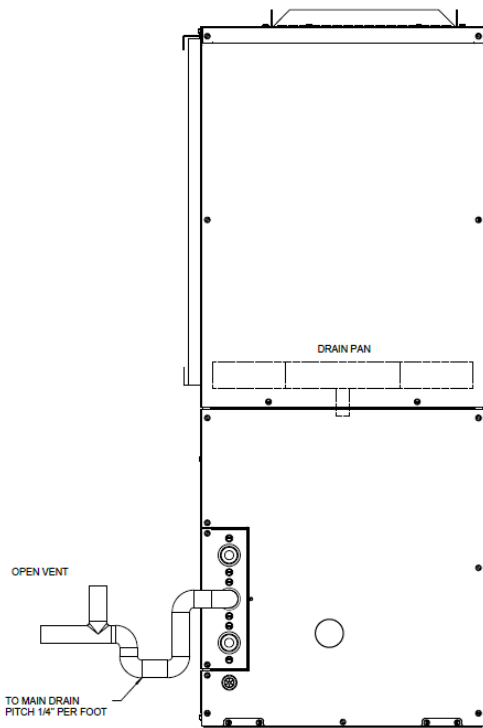

FIGURE 11 - Condensate Drain Layout

DUCTWORK

Discharge ductwork is normally used with these units. When return air ductwork is required, the unit is supplied with 1" filter rack/duct collar for connection of return air ductwork.

All duct work must be installed in accordance with National Fire Protection Assoc. Codes 90A and 90B.

Supply and Return ducts must be sized properly as to not exceed static pressure capabilities. Ducts should be adequately insulated to prevent condensation and to minimize heat loss. A flexible connector is recommended for supply air connections on metal duct systems.

DISCHARGE DUCTING

All ductwork must conform to industry standards of good practice as described in ASHRAE System Guide.

A field supplied discharge duct system will normally consist of flexible connector at the unit, a non-insulated transition piece to the full duct size, a short run of duct, an elbow without vanes and a trunk duct teeing into a branch circuit with discharge diffusers as shown in [FIGURE 12 – Unit Ducting](#).

The transition piece must not have an angle greater than 30° or severe loss of air performance can result. Do not connect the full duct size to the unit discharge collar without using a transition piece down to the size of the unit discharge collar. With metal material, the sides of the elbow and entire branch duct should be internally lined with acoustic insulation for sound attenuation.

Glass Fiber duct board material is more absorbing and may permit omission of the flexible connector.

The ductwork should be laid out so that there is no line of sight between the unit discharge and the distribution diffusers.

RETURN AIR DUCTING

Return air duct can be brought in through a wall grille and then to the unit. The return duct system will normally consist of flexible connector at the unit and a trunk duct to the return air grille. With metal duct material, the return air duct should be internally lined with acoustic insulation for sound attenuation. Glass Fiber duct board material is more absorbing and may permit omission of the flexible connector.

A 1" air duct collar flange is included on the filter rack for ducted return air application. A flexible duct collar can then be attached between a duct transition and the return air ductwork. The return air duct transition must be the same size as the return air coil face area. See [FIGURE 12 – Unit Ducting](#). Be sure to allow for proper clearance to allow for filter change outs.

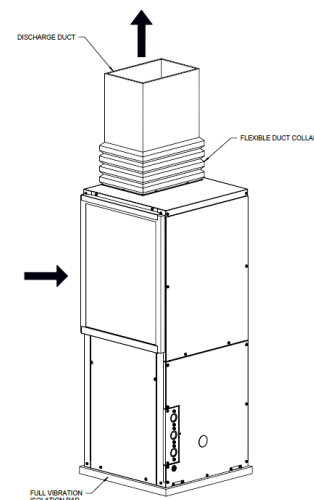

FIGURE 12 – Unit Ducting







NOTE





Follow the filter rack kit instructions & recommendations for installation.

ELECTRICAL



HIGH VOLTAGE



	WARNING	
	ELECTRIC SHOCK HAZARD	
<p>Disconnect all power supplies before servicing. Lock out/tag out to prevent accidental electrical shock. NOTE: There may be multiple power sources supplying the unit.</p>		

	WARNING	
<p>Use copper conductors only. Install all parts and panels before operation of unit. Failure to follow these warnings can result in injury or death.</p>		

All wiring must comply with local and national code requirements. Units are provided with wiring diagrams and nameplate data to provide information required for necessary field wiring.

These units are provided with a class 2 transformer for 24VAC control circuits. Should any add-on accessory or component also have a class 2 transformer furnished, care must be taken to prevent interconnecting outputs of the two transformers by using a thermostat with isolating contacts.

	WARNING	
<p>Connect ground wire to ground terminal marked "GND". Failure to do so can result in injury or death.</p>		

	CAUTION	
<p>Any device that has been furnished by the factory for field installation must be wired in strict accordance with the associated wiring diagram. Failure to do so could damage components and void warranties.</p>		

208 VOLT OPERATION

All 208-240 Volt units are factory wired for 240 Volt operation. For 208 Volt operation, moving/changing/rewiring the line voltage tap on the 24 Volt control transformer is required. See note 3 on the wiring diagram for instruction.

LOW VOLTAGE

THERMOSTAT

A standard 24 VAC Heat Pump thermostat is required that will operate the reversing valve in the fooling mode. Thermostat connections and their functions are below in **FIGURE 13 - Thermostat Connections** as follows:

- C – Transformer 24VAC Common
- O – Reversing Valve (energized in cooling)
- Y – Compressor Contactor
- R – Transformer 24VAC Hot
- G – Evaporator Blower

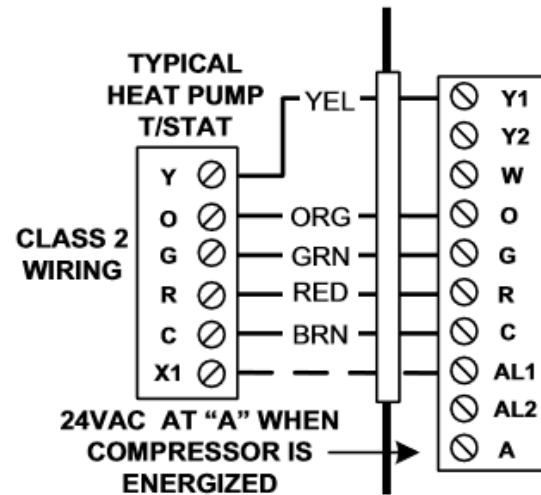

FIGURE 13 - Thermostat Connections

THERMOSTAT INSTALLATION

The Thermostat should be located on an interior wall in a larger room, away from supply duct draft. Position the thermostat back plate against the wall so that it appears level and so the thermostat wires protrude through the middle of the back plate mounting holes and drill holes with a 3/16" (5mm) bit. Install supplied anchors and secure plate to the wall. Thermostat wire must be 18 AWC wire.



APPLICATION

COOLING TOWER/BOILER APPLICATION



To ensure optimum cooling and heating performance, the cooling tower and boiler loop temperature should be maintained between 55-75°F in the heating mode and 60-95°F in the cooling mode. In the cooling mode, heat

is rejected from the heat pump’s refrigerant into the water loop. A cooling tower and/or boiler may be required to maintain proper water temperature within the water loop. In an open cooling tower, chemical water treatment is mandatory to ensure water is free of corrosive materials

In heating mode, heat is absorbed from the water loop into the heat pump’s refrigerant. A boiler may be utilized to maintain the proper water temperature within the loop.

	CAUTION	
<p>A boiler may be required in the water loop to maintain the loop water temperature between 55-75°F. Failure to maintain proper water loop temperatures could result in equipment failure and property damage, and void warranties.</p>		

A secondary heat exchanger (plate frame between the unit and the open cooling tower) may also be used. It is imperative that all air is eliminated from the closed loop side of the heat exchanger to prevent condenser fouling.

	CAUTION	
<p>The manufacturer does NOT WARRANT equipment subjected to abuse. Dirt, piping chips or other foreign material can cause damage or failure to the water or to refrigerant heat exchanger.</p>		

EXTENDED RANGE OPERATION



Piping systems expected to utilize water temperature below 50°F require the extended range option, which includes closed cell installation on all piping surfaces to eliminate condensation. This application requires sufficient antifreeze solution to prevent the water loop against extreme temperature conditions and condenser coil freezing. Frozen condenser coil are not covered under warranty. A boiler may be required to maintain the minimum water temperature within the loop.

CLOSED LOOPS

Failure to maintain proper water loop temperatures could result in equipment failure and property damage,

and void warranties. Consult the factory when running entering water temperatures below 50°F as additional pipe insulation may be required to avoid excessive sweating inside the unit. For applications below 50°F it is imperative that the system be operated with antifreeze solution.

When a secondary heat exchanger is used (i.e. plate to plate; closed loop system) it is imperative that all air is purged from the system to prevent condenser fouling.

	CAUTION	
<p>The entire water loop must be completely cleaned and flushed of all debris prior to final connections and unit operation.</p> <p>Valves should be adjusted to supply proper water flow rated for the unit.</p> <p>Failure to do so will VOID ALL FACTORY WARRANTY.</p>		

APPLICATION CONTINUED

WELL WATER APPLICATION

REQUIREMENTS:

- 50° Minimum Entering Water Temperature
- Cupronickel Refrigerant Heat Exchanger

When a water well is used exclusively for supplying water to the heat pump, a cupronickel refrigerant heat exchanger is required and the well pump should operate only when the heat pump operate. A 24 Volt contactor can be wired to the ACC1 terminal on the Control Module which can be selected to be energize prior to or at compressor start-up, which would in turn energize the water pump to operate with the heat pump.

WELL WATER APPLICATION DATA			
Potential Failure Mode	Water Chemistry Parameter	Copper	CuNi
Corrosion and Scaling	pH Level	7-9	7-9
	Hardness (Calcium or Magnesium Carbonate)	< 350 ppm	<350 ppm
	Langelier Saturation Index (LSI)	-0.5 to 0	-0.5 to 0
	Ryznar Stability Index (RSI)	6.2 – 6.8	6.2 – 6.8
	Hydrogen Sulfide	< 0.5 ppm	< 0.5 ppm
	Sulfates	< 125 ppm	< 125 ppm
	Chlorine	< 0.5 ppm	< 0.5 ppm
	Chlorides	< 20 ppm	< 150 ppm
	Carbon Dioxide	< 5 ppm	< 5 ppm
	Ammonia	< 2 ppm	< 2 ppm
	Ammonia Chloride, Nitrate, Hydroxide, Sulfate	< 0.5 ppm	< 0.5 ppm
Iron Fouling	Total Dissolved Solids (TDS)	< 1000 ppm	< 1500 ppm
	Iron, Iron Bacteria	< 0.2 ppm	< 0.2 ppm
Erosion	Iron Oxide	< 1 ppm	< 1 ppm
	Suspend Solids	< 10 ppm, < 600 Micron or 30 mesh filter size	< 10 ppm, < 600 Micron or 30 mesh filter size
	Design Water Velocity	3 GPM/TON	3 GPM/TON

Table 5 - Well Water Application Data



CAUTION



Minimum entering water temperature is 50°F. Failure to follow this warning could result in equipment failure and property damage.

The discharge water from the heat pump is not contaminated in any manner and can be disposed of in various way depending upon local codes.

Close loop and pond applications require specialized design knowledge. Do not attempt at these installations without the licensed installer the received specialized training.



CAUTION



CONTROLS

SEQUENCE OF OPERATIONS

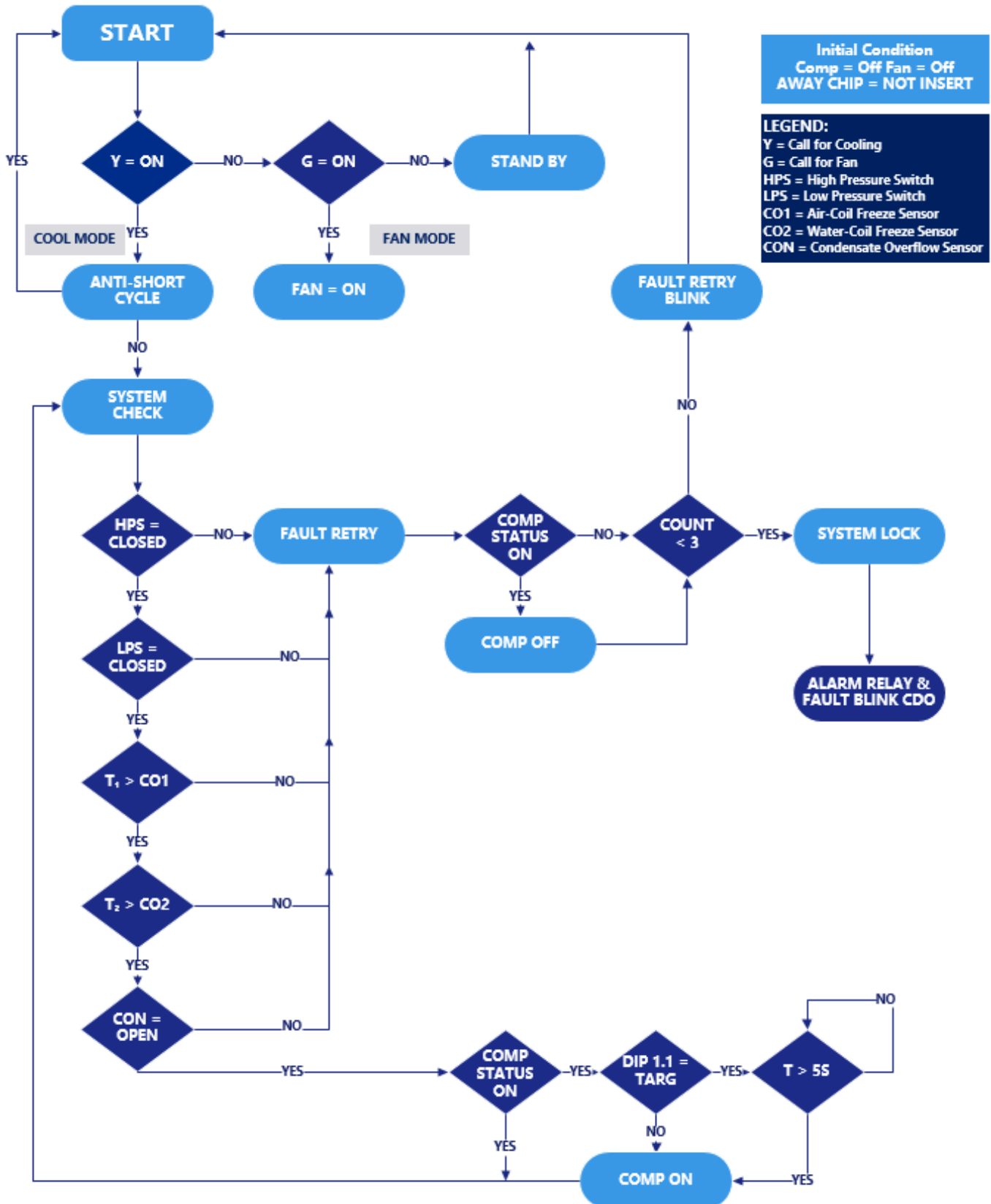

FIGURE 14 - Sequence of Operations

CONTROLS CONTINUED

WSCM CONTROL MODULE

CONTROL FEATURES

- Anti-short Cycle Protection
- Random Start
- High and low Pressure Cut-out
- Water Coil Low Temperature Cut-out
- Over/Under Voltage Protection
- Fault Retry
- Lockout with Soft and Hard Reset
- Condensate Overflow Sensor
- Diagnostic LED Display
- Test Mode
- Alarm Relay
- Accessory Relays
- Vacated Mode
- Extended Compressor Operating Monitoring

MOTOR SPEED OPERATION

An ECM blower can be driven directly from the WSCM control module. The control of the motor is based off the input signals of G, Y1, and O. The blower speed is automatically controlled via the WSCM module.

MOTOR SPEED OPERATION	
Unit Call	Fan Speed
G	G1
Y	G3
Y,O,G	G2, then G3 after 10min of run time

Table 6 - Motor Speed Operations

FIELD CONTROLLABLE FUNCTIONS

TEST MODE

The unit can be placed into test mode by shorting the test pins on the WSCM module. Once the pins are shorted, the WSCM module will enter a test mode period in which all time delays are sped up 15 times. While in test mode the yellow LED2 will light up yellow. Faults stored in memory can be cleared by entering into test mode and exiting the test mode, or by a hard reset. Test mode can be exited by shorting the test pins for approximately 3 seconds.



NOTE



Test mode will be automatically exited after a 10 minute period.



NOTE



During test mode, the control will monitor to see if CO1 and CO2 freeze thermistors are present and correctly installed. The controls will indicate fault code 19 if CO1 or CO2 are open, or if there is a jumper connecting across the free sensors terminals.

VACATED PREMISES CONTROL



NOTE



Optional Vacated Premise Kit option must be installed to operate in this mode.

The vacated premises operation is designed for extended periods of un-occupancy when the occupant wants the heat pump to operate in cooling mode for a predetermined cycle time to help control indoor air conditions. See Dip 1.7 for time selection (1 or 2 hours).

Additionally, the mode will store all faults seen over 24 hours in memory. If the same fault occurs for 4 consecutive days, the unit will go into a hard lockout.

The control kit consist of a rocker switch, wiring and a programmed chip that is installed on the WSCM module by a licensed contractor.

HOME SELECTION

If the switch is in the HOME position the heat pump will operate in its normal mode.

AWAY SELECTION

If the switch is in the AWAY position the heat pump and thermostat are set to "COOL" mode the heat pump will operate in accordance to the thermostat setting. Additionally, the heat pump will cycle on in cooling mode for 15 minute run times either 4 or 8 times per day depending on the Dip 1.7 selection. Thermostat still has priority and will cycle the unit as needed.



NOTE



If the LED display is flashing "Ay" the thermostat is not set in cooling mode.

CONTROLS CONTINUED

BOILERLESS CONTROL



The system can operate in boilerless mode by switching Dip 1.5. If CO1 goes below the setting of Dip 1.6 the compressor will be de-energized and control goes into emergency heat mode staging on "W1". The compressor will be locked out for 60 minutes to prevent nuisance cycling.

The set point for boiler less changeover temperature can be adjusted by switching Dip 1.6.

WATER-COIL LOW TEMPERATURE CUT-OUT LIMIT

Jumpers JW1-CO1 provide field selection of the temperature limit settings for CO1.

Not Clipped = 30°F Clipped = 10°F

	CAUTION	
For all applications below 50°F entering water temperature, anti-freeze solution is required. Failure to follow this warning could result in heat exchanger, equipment or property damage.		

ALARM RELAY SETTING

Jumper 3 (JW3 Alarm) provides field selection of alarm relay terminal AL2 to be jumpered to 24VAC or to be dry. The alarm relay is activated during lockout mode.

Not Clipped = AL2 Connected to "R"

Clipped = AL2 dry contacts (No connection)

DEHUMIDIFICATION MODE

The system can operate in Dehumidification mode by switching Dip 1.4 on the WSCM module. In this mode, the unit will run continuously in fan speed G2 when Y,O, G calls are given to the board. Dehumidification mode will not run in heating mode.

WSCM SAFETY FEATURES

ANTI-SHORT CYCLE PROTECTION

The WSCM module incorporates a 5 minute anti-short cycle protection for the compressor.

RANDOM START

The WSCM module features a 5-80s random start upon receiving a call to operate.

FAULT RETRY

While in Fault Retry Mode the LED will display a code representing retry and the fault code. The unit will initiate the Anti-short cycle timer and try to restart after the delay. If 3 consecutive faults occur without satisfying the thermostat the unit will go into hard lockout. The last fault causing the lockout will be stored in memory and displayed on the two digit LED display.

WATER-COIL LOW TEMPERATURE CUT-OUT (CO1)

The control module will recognize a CO1 fault during a compressor run cycle if:

- Thermistor temperature is below the selected set point limit.
- The thermistor temperature is rising at a rate less than 2°F per 30s time period. The CO1 input is bypassed for the first 120s of a compressor run cycle. On the second and third retry CO1 is bypassed for the initial 90s and 60s of run-time respectively.

AIR COIL LOW TEMPERATURE CUT-OUT (CO2)

The control module will recognize a CO2 fault during a compressor run cycle if:

- Thermistor temperature is below the selected set point limit.
- The thermistor temperature is rising at a rate less than 2°F per 30s time period. The CO2 input is bypassed for the first 120s of a compressor run cycle.

CONDENSATE OVERFLOW SENSOR

The condensate overflow sensor must sense overflow levels for 30 continuous second to initiate a COF fault. The condensate overflow sensor will be monitored during the compressor run cycle.

LOW PRESSURE

The low pressure switch must be open and remain open for 30 continuous seconds during the "on" cycle to be recognized as a low pressure fault. The low pressure switch input is bypassed for the initial 120s of compressor run-time.

HIGH PRESSURE

If the high-pressure switch opens at any time, the compressor relay is de-energized immediately.

CONTROLS CONTINUED

LOCKOUT MODE

While in Lockout Mode the LED Display will display a code representing the lockout fault code. During this lockout the compressor relay is not energized and the alarm relay is activated.

The lockout mode can be cleared by either going into test mode or a hard reset via the power disconnect

Caution: Do not restart units in lockout mode without inspection and correction of the fault condition. Failure to do so may result in equipment damage.

EXTENDED COMPRESSOR OPERATION MONITORING

If the compressor relay has been energized for four continuous hours, control module will automatically turn off the compressor relay and the compressor will enter anti-short cycle delay before restarting. During this off period, all appropriate safety will be monitored and if the compressor demand is present, the control module will energize the compressor relay.

OVER/UNDER VOLTAGE SHUTDOWN

Should an Over/Under Voltage Condition be detected the control module will shut down. Over/Under Voltage faults cause a soft lockout and the unit will return to normal operation once normal voltage has been restored. The nominal voltage run is 18.5VAC to 31VAC. If the WSCM module is in Over/Under Voltage fault for 15 minutes the alarm relay will activate.

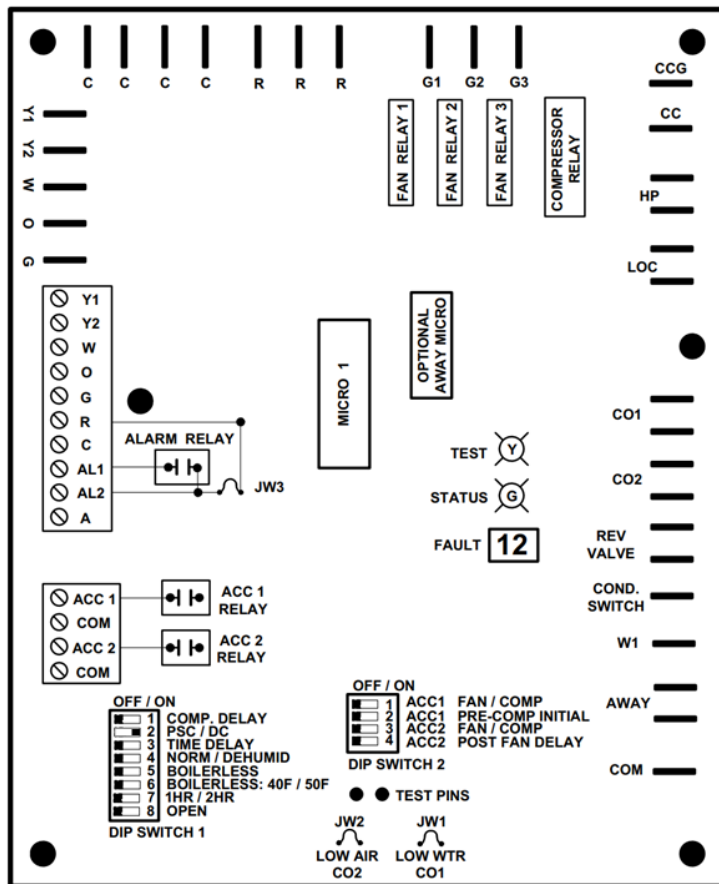

FIGURE 15 - Control Board Layout

CONTROL BOARD LAYOUT LEGEND		
CONNECTION	INPUT OR OUTPUT	DESCRIPTION
R	--	24 VAC
C	--	24 VAC (Grounded Common)
Y1	I	Input call for compressor
W	I	Input call for heating or emergency heat
O	I	Input call for reversing valve in cooling
G	I	Input call for fan operation
AL1	O	Connect to thermostat fault light – 24VAC or dry contact alarm
AL2	O	Alarm Relay 24VAC or dry contact
A	O	Output for water solenoid valve – paralleled with compressor contactor
ACC1	O	ACC1 Output for Accessory relay 1 – 24VAC between ACC1 and COM
ACC2	O	ACC2 Output for Accessory relay 2 – 24VAC between ACC2 and COM
G1	O	Connection for fan relay – low speed operation
G2	O	Connection for fan relay – medium speed operation
G3	O	Connection for fan relay – large speed operation
CC	O	Connection for compressor contactor
CCG	O	Compressor contactor common connections
HP	I	High Pressure switch input terminals
LOC	I	Low Pressure switch input terminals
CO1	I	Water coil low temperature thermistor output
CO2	I	Air coil low temperature thermistor output
RV	O	Revering valve output terminals – direct connect from “O”
COND_SW	I	Condensate overflow input terminal
W1	O	Output terminal for electric heat
COM	--	Grounded common

Table 7 - Control Board Layout Legend

CONTROLS CONTINUED

CONTROLLER OPERATION CODES	
DESCRIPTION OF OPERATION	LED READOUT
NORMAL MODE	ON (Green Light)
CONTROLLER NON-FUNCTIONAL	OFF (Green Light)
TEST MODE (pins shorted momentarily)	ON (Yellow Light)
DESCRIPTION OF OPERATION	CODE
STANDBY	ST
FAN ONLY (G active)	Fo
COOL (Y1 & O active)	Co
HEAT 1 st STAGE (Y1 active)	H1
ACCESSORY RELAY 1	A1
ACCESSORY RELAY 2	A2
VACATED PREMISES CONTROL	Ay
FAULT RETRY	rE & CODE #
LOCKOUT	Lo & CODE #
OVER / UNDER VOLTAGE SHUTDOWN	Ou & CODE #
TEMPERATURE SENSOR ERROR	SE & CODE #
DESCRIPTION OF OPERATION	CODE
TEST MODE – NO FAULT	11
TEST MODE – HP FAULT	12
TEST MODE – LP FAULT	13
TEST MODE – CO1 FAULT	14
TEST MODE – CO2 FAULT	15
TEST MODE – COND. OVERFLOW FAULT	16
TEST MODE – OVER / UNDER SHUTDOWN	17
TEST MODE – SWAPPED CO1/CO2 THERMISTORS	18

Table 8 - Control Operation Codes

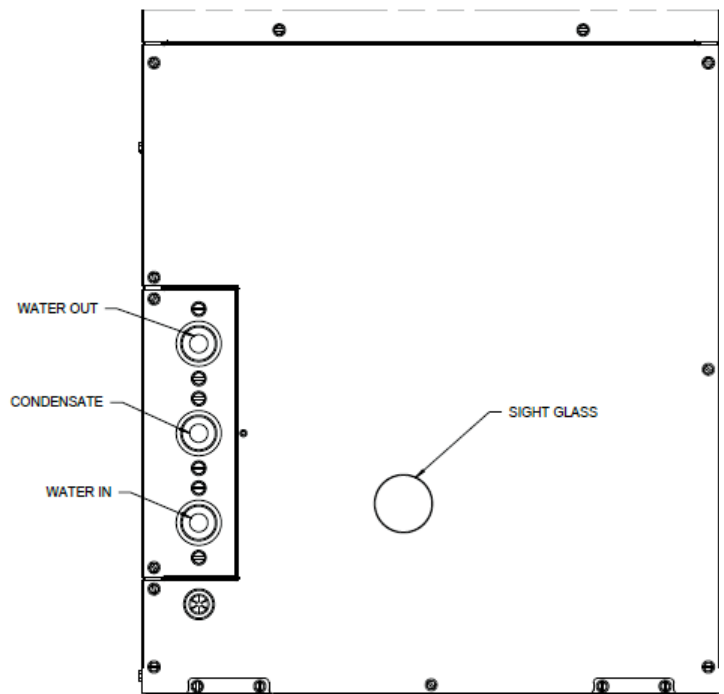

FIGURE 16 - Sight Glass Location

WSCM DIP SWITCH FUNCTIONS			
	Function	OFF	ON
DIP SWITCH 1			
1.1	Compressor Delay	No Delay	5s Delay
1.2	Motor Type	PSC Motor	ECM Motor
1.3	Blower Time Delay	None	45s
1.4	Dehumidification	None	Dehum
1.5	Boilerless	Off	On
1.6	Boilerless Setpoint	40°F	50°F
1.7	Vacated Premises	1hr	2hr
DIP SWITCH 2			
2.1	Accessory Relay Control	With Fan	With Comp
2.2	Compressor Delay	None	60s
2.3	Accessory Relay 2 Control	With Fan	With Comp
2.4	Fan Delay	None	30s

Table 9 - WSCM DIP Switch Functions

CONTROL BOX DETAIL

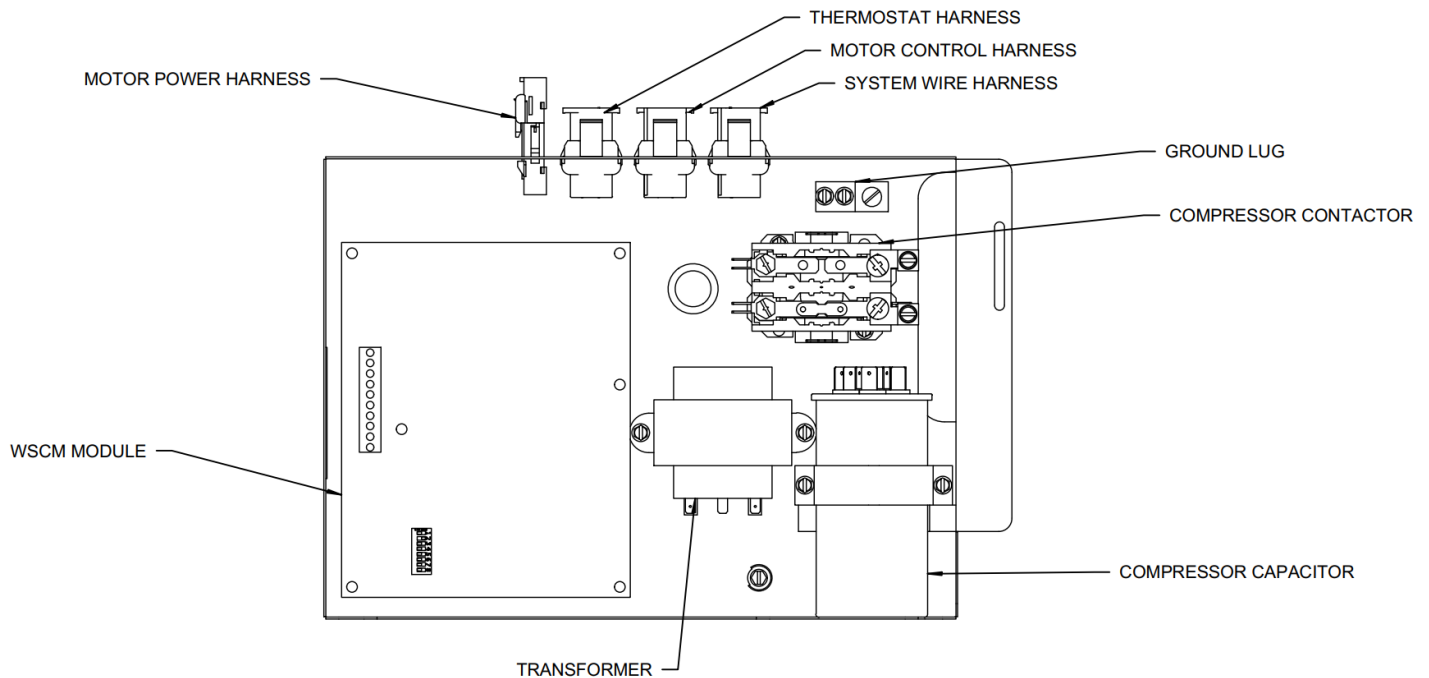

FIGURE 17 - Control Box Detail

BLOWER SPEED CONTROL

WSS6 units are equipped with a direct drive ECM blower motors with 3 speeds for WSS6006-015 or 4 speeds for WSS6018-030. See **Table 11 - WSS6 Blower Data** for airflow at different external static pressure. Select the motor speed according to the airflow and external static pressure. See wiring diagram located on unit.

For WSS6006-015 models, the default motor tap selections can be changed by moving fan speed relays between G1, G2, and G3.

For WSS6018-030 models, the default motor tap selections can be changed by moving fan speed relays between G1, G2, and G3, or by directly changing the speed tap at the motor terminal.



NOTE



High efficiency brushless DC motors are wired with power applied at all times, see illustration above. Low voltage thermostat demand and board algorithms will control its use.

REFRIGERATION SLIDE OUT DETAIL

REMOVAL

The WSS6 water-source heat pump is designed with a slide out condensing section to allow for better service access to the system.

- 1) Ensure that all power to the unit is removed and that all external disconnects are open before beginning the removal process.
- 2) Remove front electrical panel and front blower panel.
- 3) Remove any supply power connections from the unit electrical box. Disconnect the motor harness, motor control harness, unit thermostat harness and system harness connections located on the top of the electrical box. Unscrew the 3 mounting screws that attach the electrical box to the base. **Remove electrical box, refer to FIGURE 17 - Control Box Detail for more information.**
- 4) Disconnect the system supply water from unit. Unscrew the two mounting screws that attach the water connection plate to the corner post. Disconnect the condensate drain connection.
- 5) Recover the refrigerant from the unit following all appropriate code and EPA guidelines.
- 6) Unscrew the liquid line fitting at the TXV along with the suction line fitting in the air handling section.
- 7) Slide the condensing section out of the unit using the internal rails.

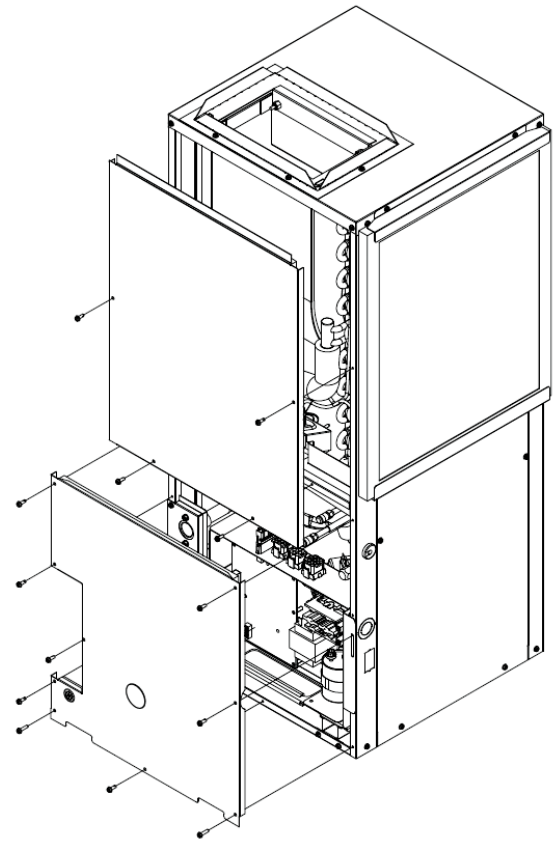

FIGURE 18 - Panel Removal

! WARNING !

⚡ ELECTRIC SHOCK HAZARD ⚡

Disconnect all power supplies before servicing. Lock out/tag out to prevent accidental electrical shock.
NOTE: There may be multiple power sources supplying the unit.

Condensing Section Weights	
Unit	Weight (lbs)
WSS6006	64
WSS6009	64
WSS6012	64
WSS6015	64
WSS6018	83
WSS6024	83
WSS6030	87
Table 10 – Condensing Section Weights	

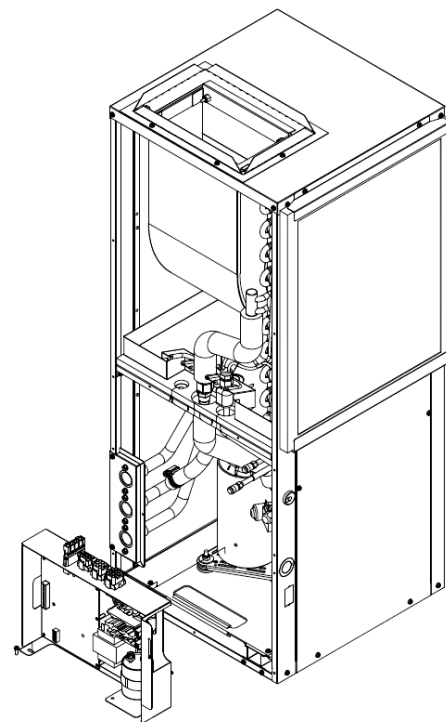

FIGURE 19 - Ebox Removal

REFRIGERATION SLIDE OUT DETAIL

ASSEMBLY

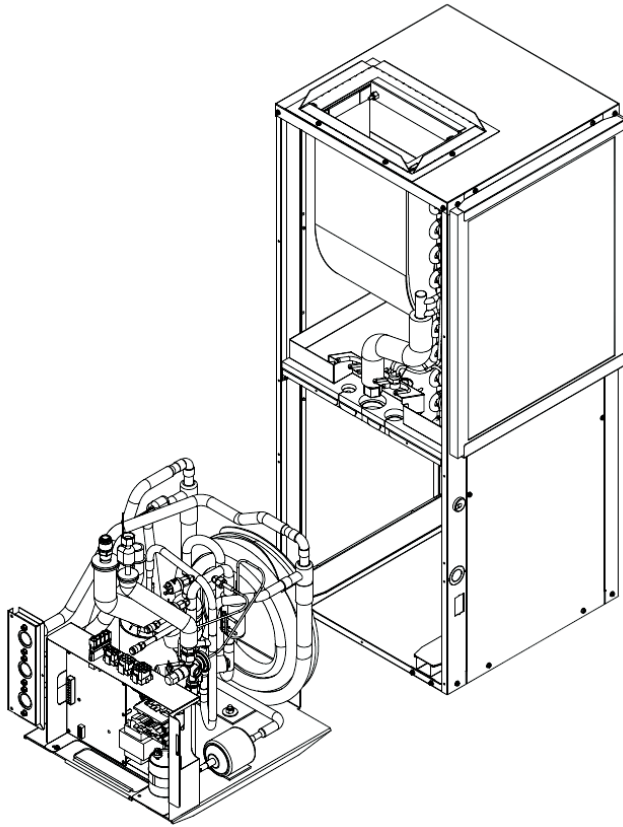

FIGURE 20 - Condensing Section Removal

- 1) Slide the condensing section back on the slides and screw the water-coil fitting panel to the corner post.
- 2) Retighten the mechanical refrigerant fittings at the air-coil vapor and liquid lines. The liquid line fitting requires a new TXV O-Ring and be sure to use a new flare seal on the vapor line connection. **Contact Factory for additional parts.**
- 3) Retighten the mechanical fittings connecting the air-coil vapor and liquid lines. The mechanical fittings must be tightened to a minimum of 40ft-lb. Backup wrenches must be used to get the required torque.
- 4) Vacuum and charge the system to nameplate.
- 5) Reconnect the system water supply lines.
- 6) Reinstall the electrical box and rewire the system supply power and blower harness.

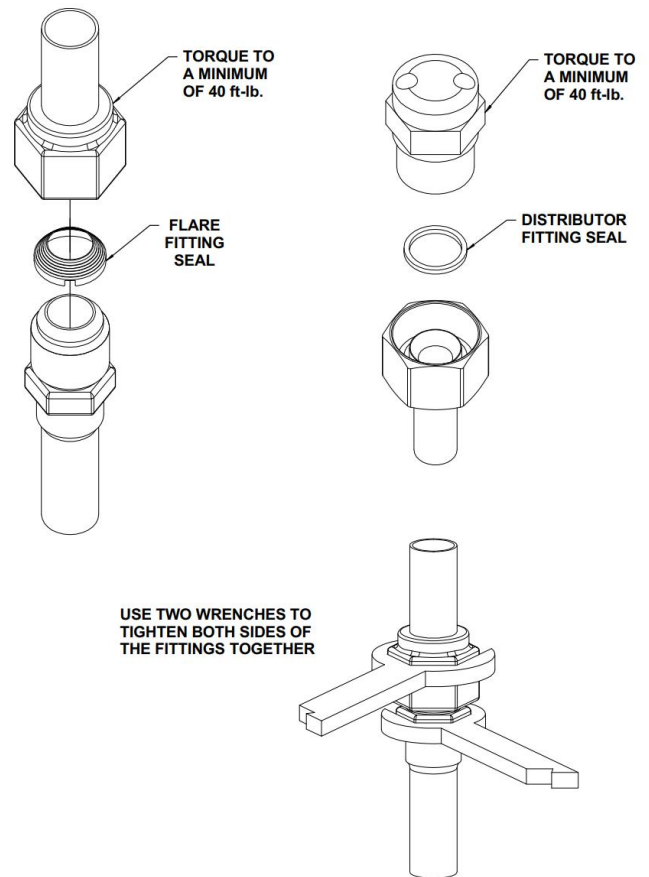

FIGURE 21 – Fitting Seal Installation

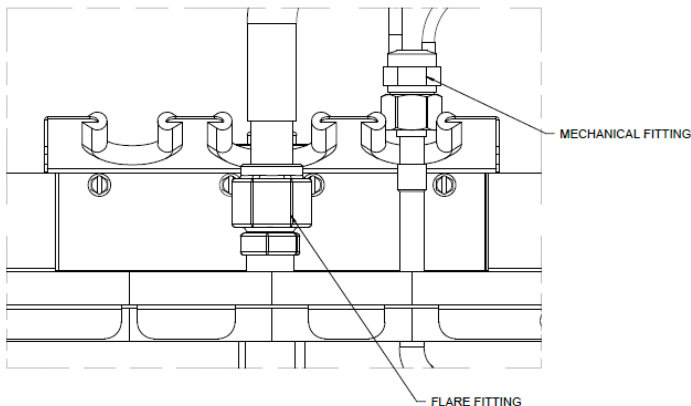
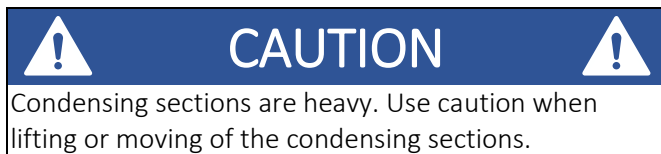
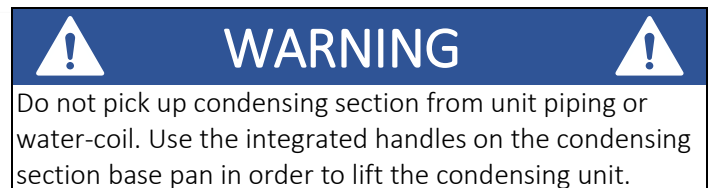





FIGURE 22 - Mechanical Fittings



PRE-STARTUP CHECKS

 WARNING 
Electrically ground the unit. Connect ground wire to ground lug. Failure to do so can result in injury or death.

 CAUTION 
Wire any field installed device such as a fan switch or thermostat furnished by the factory in strict accordance with the wiring diagram supplied with the unit. Failure to do so could result in damage to components and will void all warranties.

Before start-up, thoroughly check all the components. Optimal operation of equipment requires cleanliness. Often after installation of the equipment, additional construction activities occur. Protect the equipment from debris during these construction phases.

STARTUP INSTRUCTIONS

PRIOR TO THE STARTUP OF THE UNIT:

1. Ensure supply voltage matches nameplate data.
2. Ensure the unit is properly grounded
3. With the power off, check blower wheel set screws for proper tightness and that the blower wheel rotates freely.
4. Ensure unit will be accessible for servicing.
5. Ensure condensate line is properly sized, run, trapped, pitched and tested.
6. Ensure all cabinet openings and wiring connections have been sealed.
7. Ensure clean filters are in place.
8. Ensure all access panels are in place and secured.
9. Check that the water coil and piping had been leak checked and insulated as required.
10. Ensure that all air has been vented from the water coil.
11. Make sure that all electrical connections are tight and secure.
12. Check the electrical overcurrent protection and wiring for the correct size.
13. Verify that the low voltage wiring between the thermostat and the unit matches the wiring diagram.
14. Verify that the water piping is complete and correct.
15. Check condensate overflow sensor for proper operation and adjust position if required.

UNIT STARTUP:

1. Turn the disconnect switch to ON position.
2. Check for 24 volt from control transformer. Controller module LED should light up. If not, the power supply lines are out of phase. Turn of the main power disconnect to the unit off and change the phase.by switching any two incoming wires.
3. Set the thermostat to the lowest position. Turn the system switch to “COOL” and the fan switch to “AUTO” position. The reversing valve should energize.
4. After 5 minutes (anti-short cycle protect delay), the fan start at low speed and the compressor is running.
5. Make sure that compressor rotation is correct. If not, turn the power off and make the correction. This is 3-phase unit. Switching compressor rotation could be done by switching any two of compressor wires.
6. Turn the thermostat system to “OFF” position. The unit should stop running and the reversing valve de-energizes.
7. Leave the unit off for approximately 5 minutes to allow the system pressures to equalize. Anti-short cycle feature built in the system will keep the compressor off for 5 minutes.
8. Set the thermostat to the highest setting. Turn the system switch to “HEAT” position.
9. Verify that the unit is operating to the heating mode.
10. Set the thermostat to maintain the desired space temperature.
11. Check for vibrations, leaks, etc.
12. Verify water flow rate is correct according to specification. Adjust if necessary. If specification is not available, the nominal flow rate for this unit is 25 GPM.
13. Instruct the owner on the unit and thermostat operation.

STARTUP & PERFORMANCE CHECKLIST INSTRUCTIONS

The warranty may be void unless the [FIGURE 28 - Startup and Performance Checklist](#) is completed and returned to the warrantor. If the HVAC unit is not installed properly the warranty will be void as the manufacturer can't be held accountable for problems that stem from improper installation.

PERFORMANCE TABLES

BLOWER DATA

WSS6 BLOWER DATA										
BLOWER DATA							FACTORY BLOWER SETTINGS			
MODEL NUMBER	MOTOR TAP	FAN SPEED	IWC STATIC PRESSURE					COOLING		HEATING
			0.1	0.2	0.3	.04	0.5	1-10 MIN	10+ MIN	
WSS6006	T4	HIGH	340	310	280	250	230			
	T3	MEDIUM-HIGH	300	270	240	210	190		x	x
	T2	MEDIUM	260	230	200	170	150	x		
	T1	LOW	210	180	150	120	100			
WSS6009	T4	HIGH	470	440	410	390	360			
	T3	MEDIUM-HIGH	380	350	320	290	270		x	x
	T2	MEDIUM	300	270	240	210	190	x		
	T1	LOW	260	230	200	170	150			
WSS6012	T4	HIGH	530	490	470	440	410			
	T3	MEDIUM-HIGH	470	440	410	390	360		x	x
	T2	MEDIUM	410	380	350	320	300	x		
	T1	LOW	340	310	280	250	230			
WSS6015	T4	HIGH	670	640	610	580	560			
	T3	MEDIUM-HIGH	620	590	560	530	510			
	T2	MEDIUM	580	540	510	490	460		x	x
	T1	LOW	500	470	440	410	390	x		
WSS6018	T4	HIGH	760	730	700	670	640			
	T3	MEDIUM-HIGH	670	640	610	580	550		x	x
	T2	MEDIUM	560	530	500	470	440	x		
	T1	LOW	450	410	380	350	320			
WSS6024	T4	HIGH	980	940	910	880	850			
	T3	MEDIUM-HIGH	940	900	870	840	820		x	x
	T2	MEDIUM	880	840	810	780	750	x		
	T1	LOW	760	730	700	670	640			
WSS6030	T4	HIGH	1150	1120	1090	1060	1030			
	T3	MEDIUM-HIGH	1040	1010	970	950	920		x	x
	T2	MEDIUM	980	940	910	880	850	x		
	T1	LOW	880	840	810	780	750			

Airflow data shown is with a dry coil at 70°F DB EAT and with standard 1" filter.

Table 11 - WSS6 Blower Data

WIRING DIAGRAMS

WSS6006-015 208-230V ECM WIRING DIAGRAM

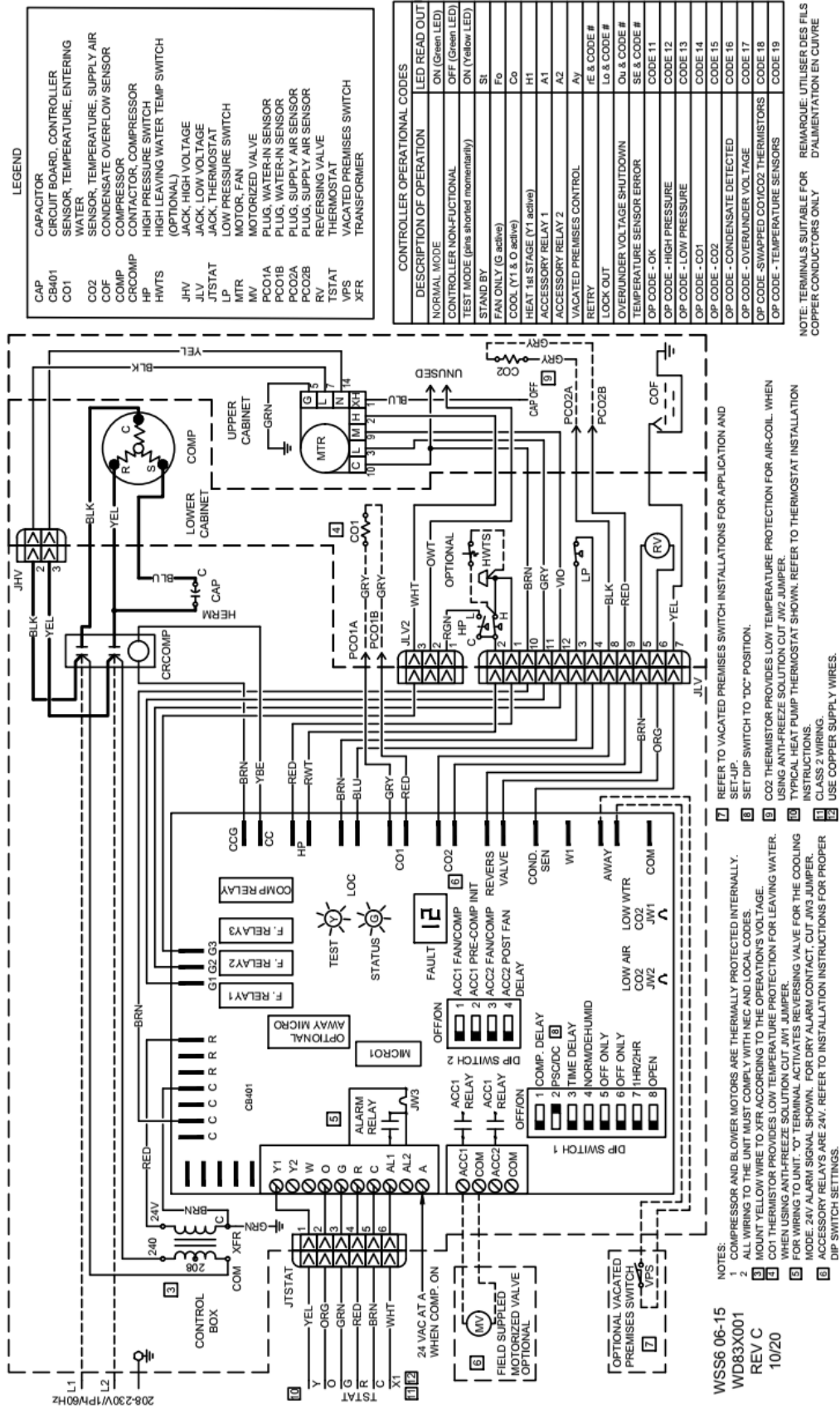

FIGURE 23 - WSS6006-015 208-230V ECM Wiring Diagram

WIRING DIAGRAMS CONTINUED

WSS6006-015 265-277V ECM WIRING DIAGRAM

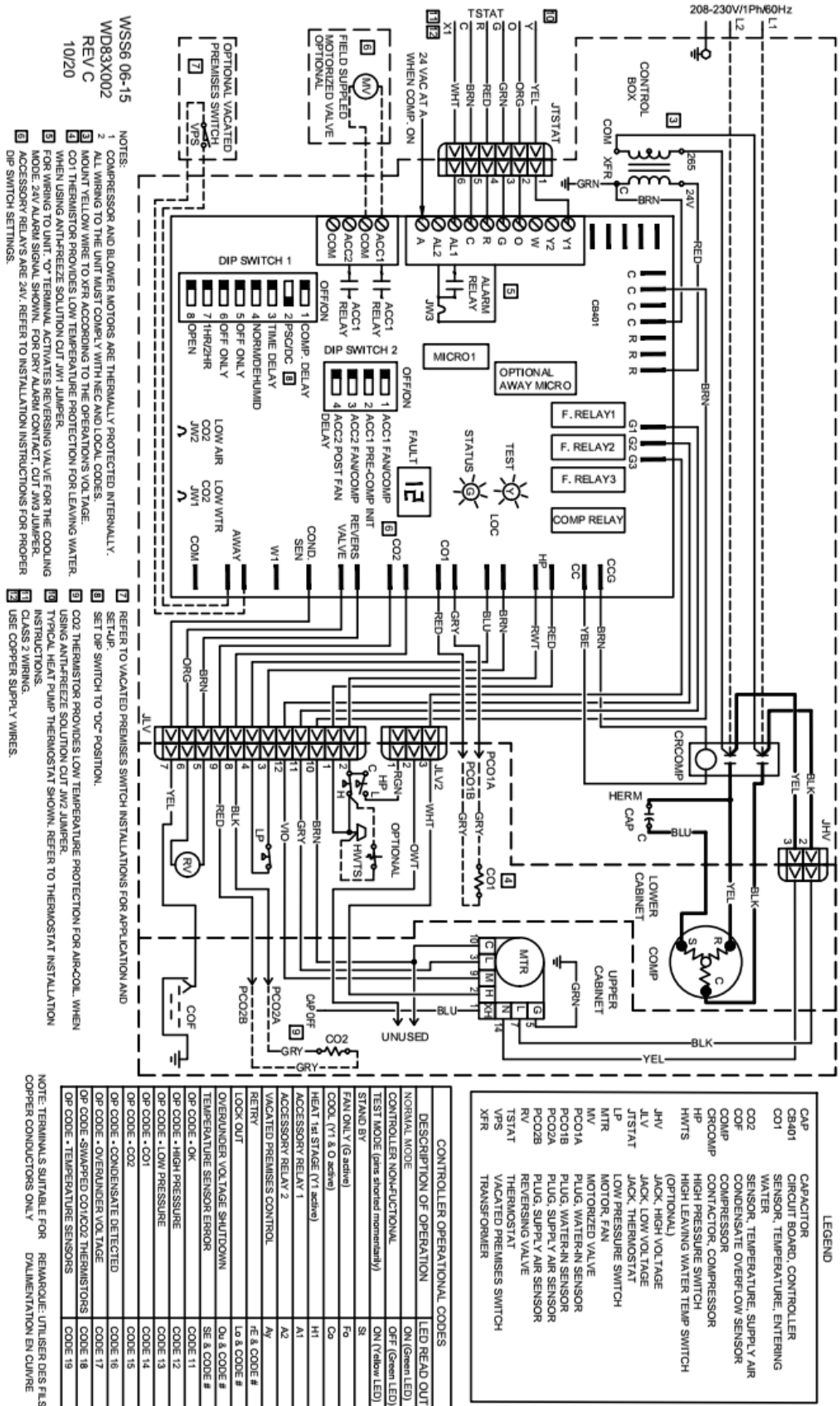

FIGURE 24 - WSS6006-015 265-277V ECM Wiring Diagram

WIRING DIAGRAMS CONTINUED

WSS6018-030 208-230V ECM WIRING DIAGRAM

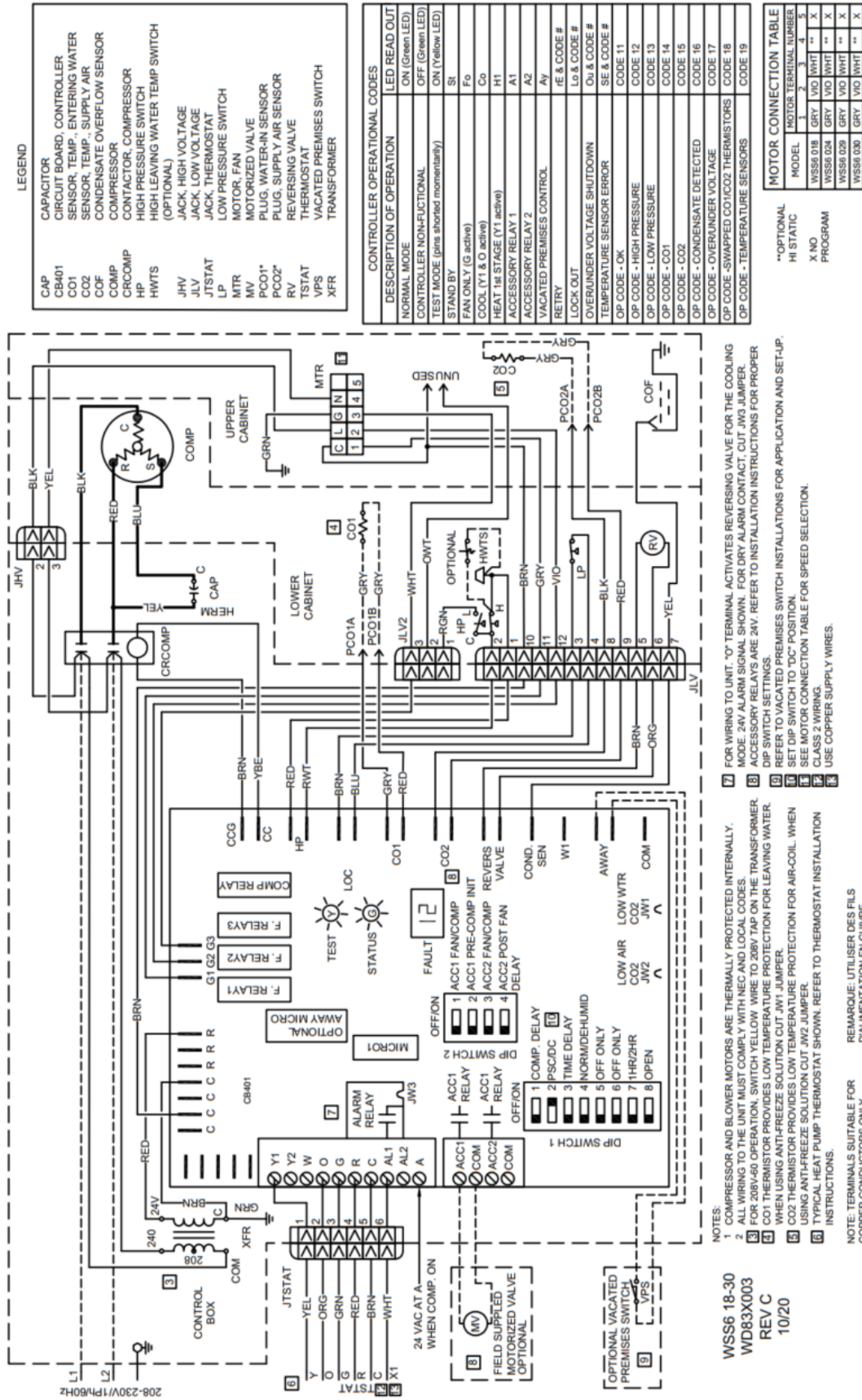
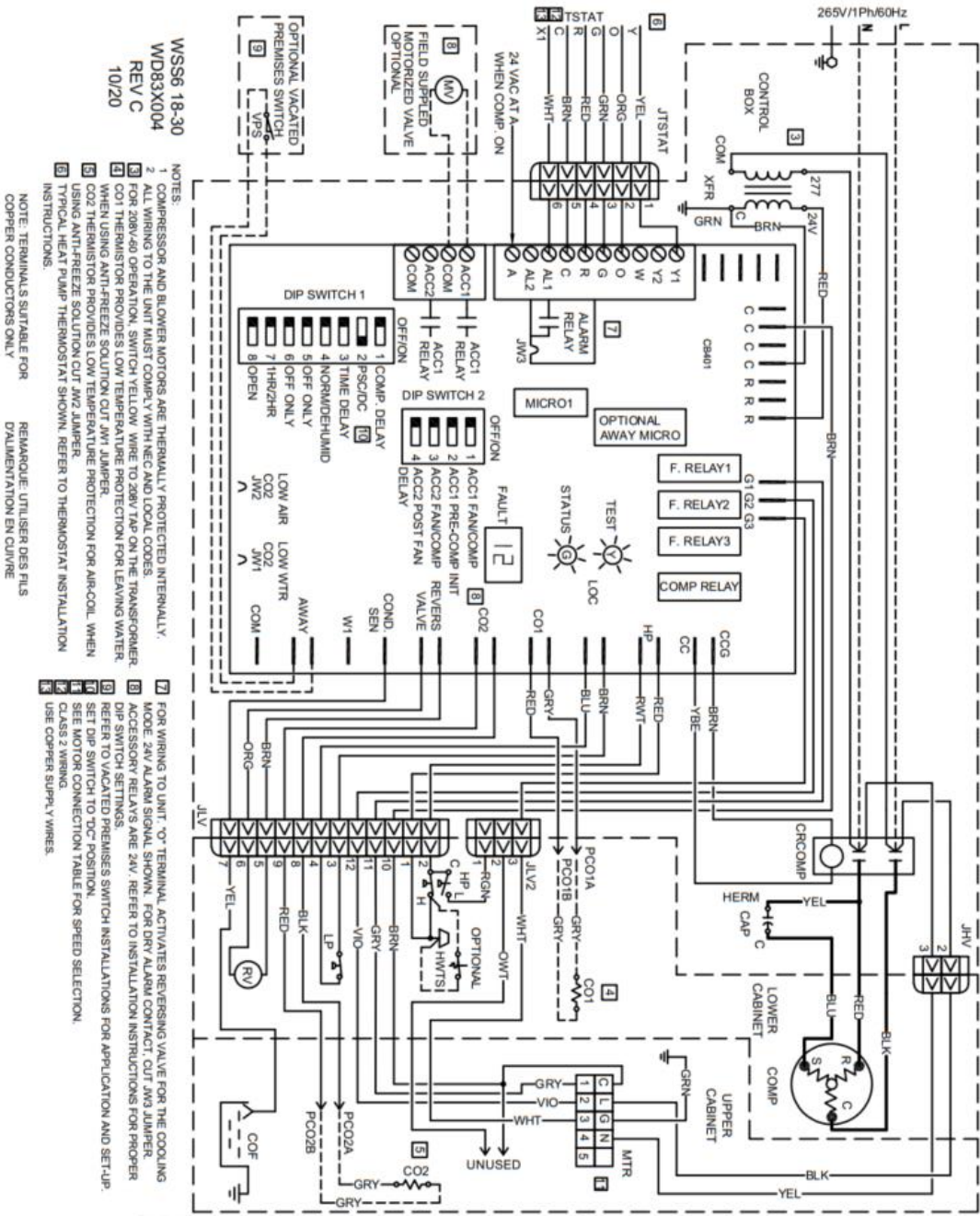

FIGURE 25 - WSS6018-030 208-230V ECM Wiring Diagram

WIRING DIAGRAMS CONTINUED

WSS6018-030 265-277 ECM WIRING DIAGRAM



WSS6 18-30
WD83X004
REV C
10/20

- NOTES:**
- COMPRESSOR AND BLOWER MOTORS ARE THERMALLY PROTECTED INTERNALLY.
 - ALL WIRING TO THE UNIT MUST COMPLY WITH NEC AND LOCAL CODES.
 - FOR 209V/60 OPERATION, SWITCH YELLOW WIRE TO 209V/TAP ON THE TRANSFORMER.
 - THERMISTOR PROVIDES LOW TEMPERATURE PROTECTION FOR LEAVING WATER.
 - WHEN USING ANTI-FREEZE SOLUTION CUT JMW JUMPER.
 - CO2 THERMISTOR PROVIDES LOW TEMPERATURE PROTECTION FOR AIR-COIL. WHEN USING ANTI-FREEZE SOLUTION CUT JMW JUMPER.
 - TYPICAL HEAT PUMP THERMOSTAT SHOWN. REFER TO THERMOSTAT INSTALLATION INSTRUCTIONS.
 - NOTE: TERMINALS SUITABLE FOR COPPER CONDUCTORS ONLY. REMARQUE: UTILISER DES FILS D'ALUMINIUM EN COURRE.

CONTROLLER OPERATIONAL CODES

DESCRIPTION OF OPERATION	LED READ OUT
NORMAL MODE	ON (Green LED)
CONTROLLER NON-FUNCTIONAL	OFF (Green LED)
TEST MODE (pins shorted momentarily)	ON (Yellow LED)
STAND BY	SI
FAN ONLY (G active)	Fo
COOL (Y1 & O active)	H1
HEAT (R1 STAGE (Y1 active)	A1
ACCESSORY RELAY 1	A2
ACCESSORY RELAY 2	Ay
VACATED PREMISES CONTROL	FE & CODE #
RETRY	LS & CODE #
LOCK OUT	OU & CODE #
OVERUNDER VOLTAGE SHUTDOWN	SE & CODE #
TEMPERATURE SENSOR ERROR	SE & CODE #
OP CODE - OK	CODE 11
OP CODE - HIGH PRESSURE	CODE 12
OP CODE - LOW PRESSURE	CODE 13
OP CODE - CO1	CODE 14
OP CODE - CO2	CODE 15
OP CODE - CONDENSATE DETECTED	CODE 16
OP CODE - OVERUNDER VOLTAGE	CODE 17
OP CODE - SWAPPED CO1/CO2 THERMISTORS	CODE 18
OP CODE - TEMPERATURE SENSORS	CODE 19

LEGEND

CAP	CAPACITOR
C401	CIRCUIT BOARD, CONTROLLER
CO1	SENSOR, TEMP., ENTERING WATER
CO2	SENSOR, TEMP., SUPPLY AIR
COF	CONDENSATE OVERFLOW SENSOR
COMP	COMPRESSOR
CRCOMP	CONTACTOR, COMPRESSOR
HP	HIGH PRESSURE SWITCH
HMTS	HIGH LEAVING WATER TEMP SWITCH (OPTIONAL)
JHV	JACK, HIGH VOLTAGE
JLV	JACK, LOW VOLTAGE
JTSTAT	JACK, THERMOSTAT
LP	LOW PRESSURE SWITCH
MTR	MOTOR, FAN
MV	MOTORIZED VALVE
PCO1*	PLUG, WATER-IN SENSOR
PCO2*	PLUG, SUPPLY AIR SENSOR
RV	REVERSING VALVE
RV	THERMOSTAT
VPS	VACATED PREMISES SWITCH
XFR	TRANSFORMER

MOTOR CONNECTION TABLE

MODEL	MOTOR TERMINAL NUMBER
WSS6 018	1 2 3 4 5
WSS6 028	1 2 3 4 5
WSS6 029	1 2 3 4 5
WSS6 030	1 2 3 4 5

FIGURE 26 - WSS6018-030 265-277 ECM Wiring Diagram

CIRCUIT SCHEMATIC

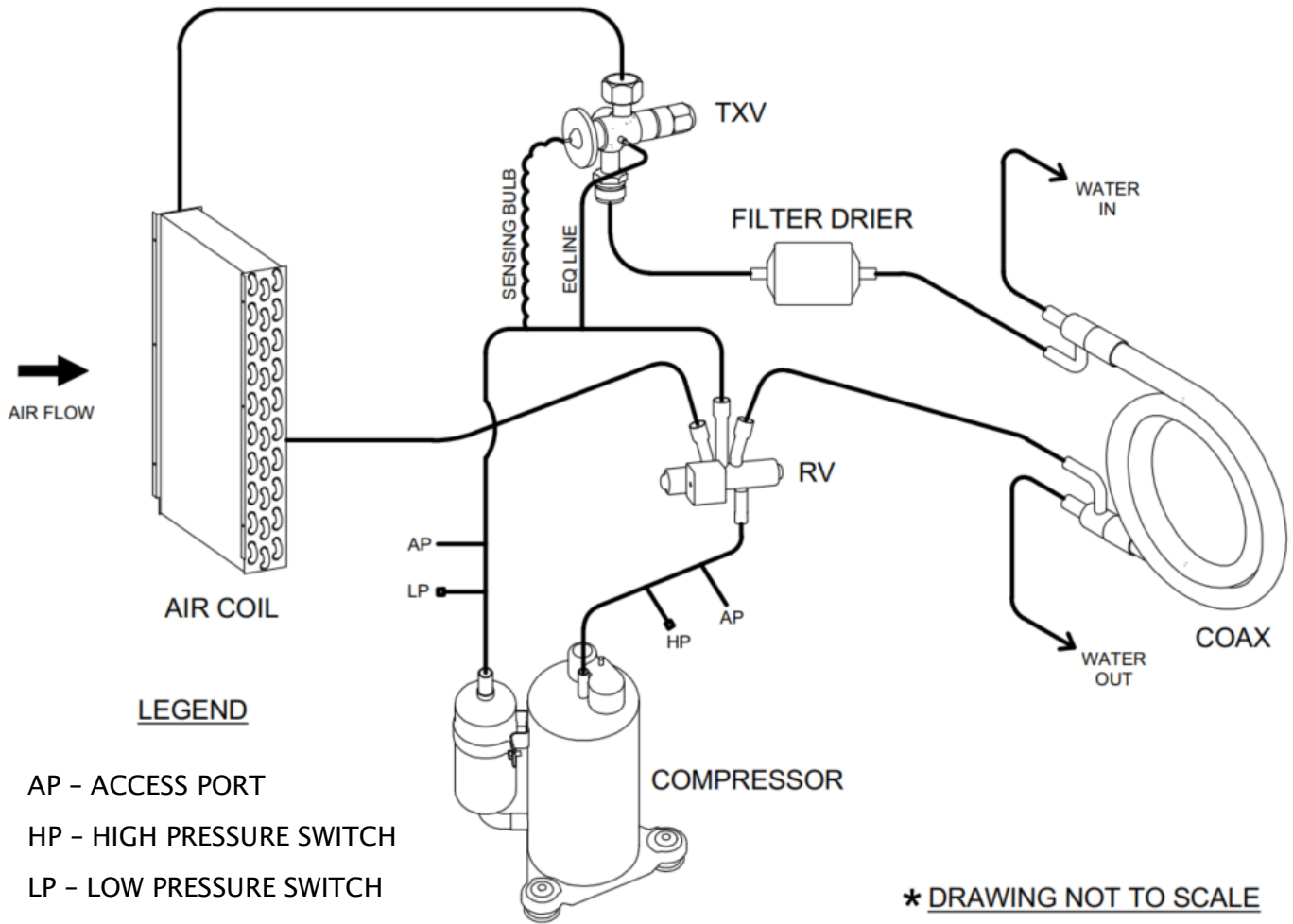

FIGURE 27 - Circuit Schematic

TROUBLESHOOTING

PROBLEM	POSSIBLE CAUSE	CHECKS & CORRECTIONS
ENTIRE UNIT DOES NOT RUN	Power supply off	Apply power; close disconnect.
	Blown Fuse	Replace fuse or reset circuit breaker. Check for correct fuses.
	Voltage supply low	If voltage is below minimum voltage specified on unit dataplate, contact lower power company. (Fault Code – Ou & 17).
	Thermostat	Set the fan to “ON”, the fan should run. Set thermostat to “COOL” and lowest temperature setting, the unit should run in the cooling mode (reversing valve energized). Set unit to “HEAT” and the highest temperature setting, the unit should run in the heating mode. If neither the blower nor compressor run in all three cases, the thermostat could be mis-wired or faulty. To ensure mis-wired or faulty thermostat verify 24 volts is available on the condenser section low voltage terminal strip between “R” and “C”, “Y” and “C”, and “O” and “C”. If blower does not operate, verify 24 volts between terminals “G” and “C” in the air handler. Replace the thermostat if defective.
BLOWER OPERATES BUT COMPRESSOR DOES NOT RUN	Thermostat	Check setting, calibration and wiring.
	Wiring	Check for loose or broken wires at compressor, capacitor or contractor.
	Safety Controls	Check control board fault LED for fault code.
	Compressor overload open	If the compressor is cool and the overload will not reset, replace the compressor.
	Compressor motor grounded	Internal wiring grounded to the compressor shell. Replace compressor. If compressor burnout, install new filter dryer.
	Compressor windings open	After compressor has cooled, check continually of compressor windings. If the windings are open, replace the compressor.
UNIT OFF ON HIGH PRESSURE CONTROL FAULT CODE 12	Discharge pressure too high	In “COOLING” mode: Lack of or inadequate water flow. Entering water temperature too warm. Scaled or restricted water to refrigerant heat exchanger. In “HEATING” mode: Lack of or inadequate water flow. Entering water temperature too cold. Scaled or restricted water to refrigerant heat exchanger.
	Refrigerant charge	The unit is overcharged with refrigerant. Reclaim refrigerant, evacuate and recharge with factory recommended charge.
	High pressure switch	Check for defective or improperly calibrated high pressure switch.
UNIT OFF ON LOW PRESSURE CONTROL FAULT CODE 13	Suction Pressure too low	In “COOLING” mode: Lack of or inadequate airflow. Entering air temperature too cold. Blower inoperative, clogged filter or restriction in ductwork. In “HEATING” mode: Lack of or inadequate water flow. Entering water temperature too cold. Scaled or restricted water to refrigerant heat exchanger.
	Refrigerant charge	The unit is low on refrigerant. Check for refrigerant leak, repair, evacuate and recharge with factor recommended charge.
	Low pressure switch	Check for defective or improperly calibrated low pressure switch.

Table 12 - Troubleshooting Table

TROUBLESHOOTING CONTINUED

PROBLEM	POSSIBLE CAUSE	CHECKS & CORRECTIONS
UNIT SHORT CYCLES	Unit oversized	Recalculate heating and cooling loads.
	Thermostat	Thermostat installed near a supply air register, relocate thermostat. Check heat anticipator.
	Wiring and controls	Loose connections in the wiring or a defective compressor contactor.
INSUFFICIENT COOLING OR HEATING	Unit undersized	Recalculate heating and cooling loads. If not excessive, possibly adding insulation will rectify the situation.
	Loss of conditioned air by leaks	Check for leaks in ductwork or introduction of ambient air through doors or windows.
	Airflow	Lack of adequate airflow or improper distribution of air. Replace dirty air filter.
	Refrigerant charge	Low on refrigerant charge causing inefficient operation.
	Compressor	Check for defective compressor. If discharge is too low and suction pressure is too high, compressor is not pumping properly. Replace compressor.
	Reversing valve	Defective reversing valve creating bypass of refrigerant from discharge to suction side of compressor. Discharge is too low and suction is too high. Replace reversing valve.
	Operating pressures	Compare unit operating pressures to the pressure / temperature chart for the unit.
	Refrigerant metering device	Check for possible restriction or defect. Replace is necessary.
Moisture, non-condensables	The refrigerant system may be contaminated with moisture or non-condensables. Reclaim refrigerant, evacuate and recharge with factory recommended charge. Replace filter dryer.	

Table 13 - Troubleshooting Table Continued

SUPPLEMENTAL DATA / TABLES

PRESSURE & TEMPERATURE DATA

WSS6006 PRESSURE & TEMPERATURE DATA									
Entering Water Temp	Water Flow Rate	COOLING				HEATING			
		Suction Pressure	Discharge Pressure	Air Temp Drop	Water Temp Rise	Suction Pressure	Discharge Pressure	Air Temp Drop	Water Temp Rise
°F	GPM	psig	psig	°F	°F	psig	psig	°F	°F
50	1	136-146	203-223	23-29	19-23	99-109	279-299	21-27	9-13
	2	134-144	178-198	23-29	9-13	110-120	287-307	22-28	4-8
70	1	139-149	271-291	22-28	18-22	137-147	309-329	26-32	12-16
	2	138-148	246-266	22-28	8-12	153-163	323-343	28-34	6-10
90	1	143-153	354-374	20-26	17-21	181-191	346-366	32-38	16-20
	2	142-152	331-351	20-26	8-12	206-216	369-389	36-42	8-12
110	1	147-157	455-475	19-25	16-20	Operation Not Recommended			
	2	147-157	436-456	19-25	7-11				

Table 14 - WSS6006 Pressure & Temperature Data

WSS6009 PRESSURE & TEMPERATURE DATA									
Entering Water Temp	Water Flow Rate	COOLING				HEATING			
		Suction Pressure	Discharge Pressure	Air Temp Drop	Water Temp Rise	Suction Pressure	Discharge Pressure	Air Temp Drop	Water Temp Rise
°F	GPM	psig	psig	°F	°F	psig	psig	°F	°F
50	1.5	130-140	192-212	23-29	15-19	95-105	291-311	24-30	9-13
	2.5	129-139	174-194	23-29	8-12	106-116	302-322	27-33	3-7
70	1.5	132-142	259-279	22-28	14-18	131-141	326-346	31-37	13-17
	2.5	131-141	240-260	22-28	8-12	149-159	346-365	34-40	5-9
90	1.5	134-144	339-359	20-26	13-17	174-184	370-390	38-44	17-21
	2.5	133-143	321-341	20-26	7-11	202-212	399-419	43-49	7-11
110	1.5	138-148	438-458	19-25	12-16	Operation Not Recommended			
	2.5	137-147	422-442	19-25	7-11				

Table 15 - WSS6009 Pressure & Temperature Data

WSS6012 PRESSURE & TEMPERATURE DATA									
Entering Water Temp	Water Flow Rate	COOLING				HEATING			
		Suction Pressure	Discharge Pressure	Air Temp Drop	Water Temp Rise	Suction Pressure	Discharge Pressure	Air Temp Drop	Water Temp Rise
°F	GPM	psig	psig	°F	°F	psig	psig	°F	°F
50	1.5	129-139	223-243	21-27	20-24	98-108	273-293	20-26	8-12
	3	126-136	190-210	22-28	9-13	108-118	282-302	22-28	4-8
70	1.5	133-143	288-308	20-26	18-22	135-145	306-326	27-33	12-16
	3	131-141	253-273	21-27	8-12	151-161	321-341	29-35	6-10
90	1.5	136-146	366-386	19-25	17-21	178-188	346-366	34-40	16-20
	3	134-144	331-351	19-25	8-12	203-213	370-390	38-44	8-12
110	1.5	140-150	459-479	18-24	15-19	Operation Not Recommended			
	3	140-150	426-446	18-24	7-11				

Table 16 - WSS6012 Pressure & Temperature Data

SUPPLEMENTAL DATA / TABLES

PRESSURE & TEMPERATURE DATA

WSS6015 PRESSURE & TEMPERATURE DATA									
Entering Water Temp	Water Flow Rate	COOLING				HEATING			
		Suction Pressure	Discharge Pressure	Air Temp Drop	Water Temp Rise	Suction Pressure	Discharge Pressure	Air Temp Drop	Water Temp Rise
°F	GPM	psig	psig	°F	°F	psig	psig	°F	°F
50	3.75	128-138	204-224	22-28	18-22	93 - 103	287 - 307	22 - 28	9 - 13
	7.5	126-136	179-199	22-28	8-12	102 - 112	296 - 316	24 - 30	4 - 8
70	3.75	133-143	273-293	21-27	17-21	128 - 138	321 - 341	28 - 34	12 - 16
	7.5	131-141	245-265	21-27	8-12	144 - 154	338 - 358	31 - 37	6 - 10
90	3.75	138-148	359-379	20-26	17-21	169 - 179	366 - 386	35 - 41	16 - 20
	7.5	136-146	327-347	20-26	7-11	194 - 204	395 - 415	39 - 45	8 - 12
110	3.75	144-154	462-482	18-24	16-20	Operation Not Recommended			
	7.5	142-152	430-450	19-25	7-11				

Table 17 - WSS6015 Pressure & Temperature Data

WSS6018 PRESSURE & TEMPERATURE DATA									
Entering Water Temp	Water Flow Rate	COOLING				HEATING			
		Suction Pressure	Discharge Pressure	Air Temp Drop	Water Temp Rise	Suction Pressure	Discharge Pressure	Air Temp Drop	Water Temp Rise
°F	GPM	psig	psig	°F	°F	psig	psig	°F	°F
50	2.25	127-137	199-219	25-31	19-23	98-108	319-339	26-32	7-11
	4.5	125-135	176-196	25-31	9-13	107-117	329-349	27-33	3-7
70	2.25	132-142	268-288	23-29	18-22	136-146	360-380	33-39	11-15
	4.5	130-140	244-264	24-30	8-12	151-161	376-396	35-41	5-9
90	2.25	138-148	354-374	22-28	18-22	181-191	410-430	71-47	14-18
	4.5	136-146	329-349	23-29	8-12	204-214	436-456	44-50	7-11
110	2.25	143-153	457-477	21-27	17-21	Operation Not Recommended			
	4.5	142-152	433-453	21-27	8-12				

Table 18 - WSS6018 Pressure & Temperature Data

WSS6024 PRESSURE & TEMPERATURE DATA									
Entering Water Temp	Water Flow Rate	COOLING				HEATING			
		Suction Pressure	Discharge Pressure	Air Temp Drop	Water Temp Rise	Suction Pressure	Discharge Pressure	Air Temp Drop	Water Temp Rise
°F	GPM	psig	psig	°F	°F	psig	psig	°F	°F
50	3	117-127	208-228	23-29	18-22	104-114	307-327	25-29	8-12
	6	117-127	178-198	23-29	8-12	112-122	316-336	25-31	3-7
70	3	121-131	285-305	22-28	18-22	139-149	343-363	30-36	11-15
	6	121-131	247-267	22-28	8-12	153-163	357-377	32-38	5-9
90	3	127-137	380-400	21-27	18-22	181-191	384-404	36-42	15-19
	6	126-136	337-357	21-27	8-12	203-213	405-425	40-46	7-11
110	3	134-144	515-535	19-25	18-22	Operation Not Recommended			
	6	132-142	448-468	20-26	7-11				

Table 19 - WSS6024 Pressure & Temperature Data

SUPPLEMENTAL DATA / TABLES

PRESSURE & TEMPERATURE DATA

WSS6029 PRESSURE & TEMPERATURE DATA									
Entering Water Temp	Water Flow Rate	COOLING				HEATING			
		Suction Pressure	Discharge Pressure	Air Temp Drop	Water Temp Rise	Suction Pressure	Discharge Pressure	Air Temp Drop	Water Temp Rise
°F	GPM	psig	psig	°F	°F	psig	psig	°F	°F
50	3.75	128-138	204-224	22-28	18-22	97-107	320-340	24-30	8-12
	7.5	126-136	179-199	22-28	8-12	106-116	330-350	25-31	3-7
70	3.75	133-143	273-293	21-27	17-21	134-144	362-382	30-36	11-15
	7.5	131-141	245-265	21-27	8-12	149-159	378-398	32-38	5-9
90	3.75	138-148	359-379	20-26	17-21	179-189	412-432	37-43	14-18
	7.5	136-146	327-347	20-26	7-11	201-211	438-458	40-46	7-11
110	3.75	144-154	462-482	18-24	16-20	Operation Not Recommended			
	7.5	142-152	430-450	19-25	7-11				

Table 20 - WSS6029 Pressure & Temperature Data

WATER PRESSURE DROP

WATER PRESSURE DROP (psi) DATA							
MODEL	GPM	Entering Water Temperature °F					
		50	60	70	80	90	100
WSS6006	0.8	0.6	0.6	0.5	0.5	0.5	0.5
	1.1	0.7	0.7	0.7	0.7	0.7	0.7
	1.5	0.9	0.9	0.9	0.9	0.9	0.9
WSS6009	1.1	0.7	0.7	0.7	0.7	0.7	0.7
	1.7	1.3	1.1	0.9	0.7	0.5	0.3
	2.3	2.2	2.0	1.8	1.6	1.4	1.2
WSS6012	1.5	0.9	0.9	0.9	0.9	0.9	0.9
	2.3	2.2	2.0	1.8	1.6	1.4	1.2
	3.0	3.4	3.2	3.0	2.8	2.6	2.4
WSS6015	1.9	1.6	1.4	1.2	1.0	0.8	0.6
	2.8	3.1	2.9	2.7	2.5	2.3	2.1
	3.8	4.7	4.5	4.3	4.1	3.9	3.7
WSS6018	2.3	1.1	0.9	0.8	0.7	0.6	0.5
	3.4	2.0	1.7	1.4	1.0	0.7	0.4
	4.5	3.0	2.7	2.3	2.0	1.7	1.3
WSS6024	3.0	1.7	1.4	1.0	0.7	0.4	0.3
	4.5	3.0	2.7	2.3	2.0	1.7	1.3
	6.0	4.3	4.0	3.6	3.3	3.0	2.6
WSS6030	3.6	2.3	1.9	1.6	1.2	0.9	0.6
	5.4	3.8	3.5	3.2	2.8	2.5	2.1
	7.3	5.4	5.1	4.7	4.4	4.1	3.7

Table 21 - Water Pressure Drop (psi) Data

SUPPORT MATERIAL

REFERENCE CALCULATIONS

HEATING

$$LDB = EDB + \frac{QH}{GPM \times 500}$$

$$LWT = EAT + \frac{QA}{cfm \times 1.08}$$

COOLING

$$LDB = EDB - \frac{SC}{cfm \times 1.08}$$

$$LWT = EWT + \frac{QR}{GPM \times 500}$$

$$LC = QC - SC$$

$$SHR = \frac{SC}{QC}$$

ABBREVIATIONS & DEFINITIONS

LDB = Leaving air temperature dry bulb °F

EDB = Entering air temperature dry bulb °F

GPM = Water flow rate gallons per minute

CFM = Airflow rate cubic feet per minute

QH = Heating capacity Btuh

QA = Heat of absorption Btuh

SC = Sensible cooling capacity Btuh

QR = Heat of rejection Btuh

LC = Latent cooling capacity Btuh

SHR = Sensible heat ratio

COMMON CONVERSIONS

Air Flow	l/s = CFM x .47
Water Flow	l/s = GPM x .06
Static Pressure	Pa = IWC x 249
Water Pressure Drop	FOH = PSI x 2.3
Temperature	°C = (°F - 32) x 5/9
Power	kW = Btuh / 3412
Weight	oz = lb x 16
Weight	kg = lb / 2.2
EER	COP x 3.413
COP	EER / 3.413

PREVENTATIVE MAINTENANCE

To achieve maximum performance and service life of equipment, a formal schedule of regular maintenance should be established and adhered to.



CAUTION



All appropriate personal protection equipment should be worn when servicing or maintaining this unit.

Personal injury can result from sharp metal edges, moving parts, and hot or cold surfaces.

FAN

The fan should be inspected and cleaned annually in conjunction with maintenance of the motor and bearings. It is important to keep the fan section and motor clean and free from obstruction to prevent imbalance, vibration, and improper operation.



WARNING



ELECTRIC SHOCK HAZARD



Check motor connections to ensure they are secure and in accordance with the unit wiring diagram.

ECM motors have line voltage power applied at all times. **MAKE SURE POWER IS DISCONNECTED BEFORE SERVICING.**

FILTER

The air filter should be cleaned or replaced every 30 days or more frequently if severe operating conditions exist. Always replace the filter with the same type and size as originally furnished.

COIL

Clean all heat transfer surfaces and remove all dirt, dust, and contaminants that potentially impairs air flow using industry accepted practices. Care should be taken not to bend coil fin material.

CONDENSATE DRAIN PAN AND PIPE

Check and clean all dirt and debris from pan. Ensure drain line is free flowing and unobstructed.

MAINTENANCE UPDATES

Check regularly for a current copy of the maintenance program log which can be found at under "product information".

CLEANING/FLUSHING

Before the unit is connected to the supply water, the water circulating system must be cleaned and flushed to remove any dirt or debris for the system.

1. Connect the supply and return water lines together in order to bypass the unit. This will prevent dirt or debris from getting into the system during the flushing process.
2. Start the main water circulating pump and allow for water to circulate in the system. Open drains at the lowest point in the system and drain out the water while simultaneously filling the loop with city water. Continue to exchange the loop water with the city water for a minimum of two hours, or until drain water is clear. During this time, check to make sure there are no leaks within the system.
3. Open all drains and vents to drain water system and refill with clean water. Test the system water quality and treat as necessary in order to bring water quality to within requirements for the system. Water PH level should be 7.5 to 8.5. Antifreeze may be added if required.
4. Connect the water-source heat pump supply and return lines, following proper installation procedures outlined in the piping installation section. After the installation has been checked for leaks, bring the water-loop to the desired set point and vent any air within the loop.

UNIT PERFORMANCE

Record performance measurements of volts, amps and water temperature differences (both heating and cooling). A comparison of logged data with start-up and other annual data is useful as an indicator of general equipment condition.

UNIT LOCKOUT

Air or water problem could cause periodic lockouts. The lockout (shutdown) of the units is a normal protective result. Check for dirt in the water system, water flow rates, water temperatures, airflow rates (may be caused by dirty filter) and air temperatures.

STARTUP & PERFORMANCE CHECKLIST



CUSTOMER _____ DATE _____ STARTUP DATE _____
 ADDRESS _____ PHONE # _____ JOB NUMBER _____
 HYDROTECH MODEL _____ SERVICING COMPANY _____
 SERIAL # _____ TECHNICIAN _____
 SERIAL # EXAMPLE _____ (1 Letter) – (2 #s) – (1 letter) – (6 #s)

VISUAL INSPECTION

- Air Filter Condition
- Evaporate Coil Condition
- Blower Wheel
- Signs of sweating on plenum / cabinet
- Signs of condensate outside pan
- Condensate Drain Clear

ACCESSORIES INSTALLED

- Hard Start Kit
Type/Brand: _____
- Compressor Cover
- Vacated Premises Switch

CONTROL MODULE SWITCH POSITION

Dip Switch #1

Off	On
<input type="checkbox"/>	<input type="checkbox"/>
<input type="checkbox"/>	<input type="checkbox"/>
<input type="checkbox"/>	<input type="checkbox"/>
<input type="checkbox"/>	<input type="checkbox"/>
<input type="checkbox"/>	<input type="checkbox"/>
<input type="checkbox"/>	<input type="checkbox"/>
<input type="checkbox"/>	<input type="checkbox"/>
<input type="checkbox"/>	<input type="checkbox"/>

Switch #1
Switch #2
Switch #3
Switch #4
Switch #5
Switch #6
Switch #7
Switch #8

Dip Switch #2

Off	On
<input type="checkbox"/>	<input type="checkbox"/>
<input type="checkbox"/>	<input type="checkbox"/>
<input type="checkbox"/>	<input type="checkbox"/>
<input type="checkbox"/>	<input type="checkbox"/>

Switch #1
Switch #2
Switch #3
Switch #4

Unit in Lock Out? _____

Fault Code Displayed in Test Mode? _____

PROBLEM SUMMARY

CORRECTIVE ACTIONS TAKEN

UNIT OPERATION

Primary Voltage to the Heat Pump: _____
 Transformer Secondary Voltage: _____
 Unit Grounded? _____
 Low Side PSIG: _____ Vapor Line Temp: _____ Saturated Temp: _____
 [Vapor Line Temp – Saturated Temp = **Superheat**]*
 High Side PSIG: _____ Saturated Temp: _____ Liquid Line Temp: _____
 [Saturated Temp – Liquid Line Temp = **Sub Cooling**]*

DUCT SYSTEM STATIC PRESSURE

Supply Static Pressure: _____
 Return Static Pressure: _____
 Total External Static Pressure: _____

EVAPORATOR COIL TEMPERATURES:

Evaporator Coil EAT Dry Bulb: _____
 Evaporator Coil LAT Dry Bulb: _____
 Delta: _____
 Evaporator Coil EAT Dry Bulb: _____
 Evaporator Coil EAT Dry Bulb: _____
 Delta: _____

HEAT EXCHANGER TEMPERATURE

Cond Entering Water Temp: _____
 Cond Leaving Water Temp: _____
 Cond Temp Rise: _____

The warranty may be void unless the Startup & Performance Checklist is completed and returned to the warrantor. If the HVAC unit is not installed properly the warranty will be void as the manufacturer can't be held accountable for problems that stem from improper installation.

FIGURE 28 - Startup and Performance Checklist

NOTES

NOTES

NOTES

The logo for First Co. is displayed in a white, cursive font on a blue, wavy banner that has a slight 3D effect with a shadow.

WSS6 Series IOM
“Slim” Water Source Heat Pump
16 EER
Installation, Operations & Maintenance Manual

Manufactured by:
First Co.
8273 Moberly Lane
Dallas, TX 75227
www.firstco.com