



# WSH6

*Water Source Heat Pump*



Horizontal

3/4 thru 6 Tons

16 EER



R454B

# NOMENCLATURE

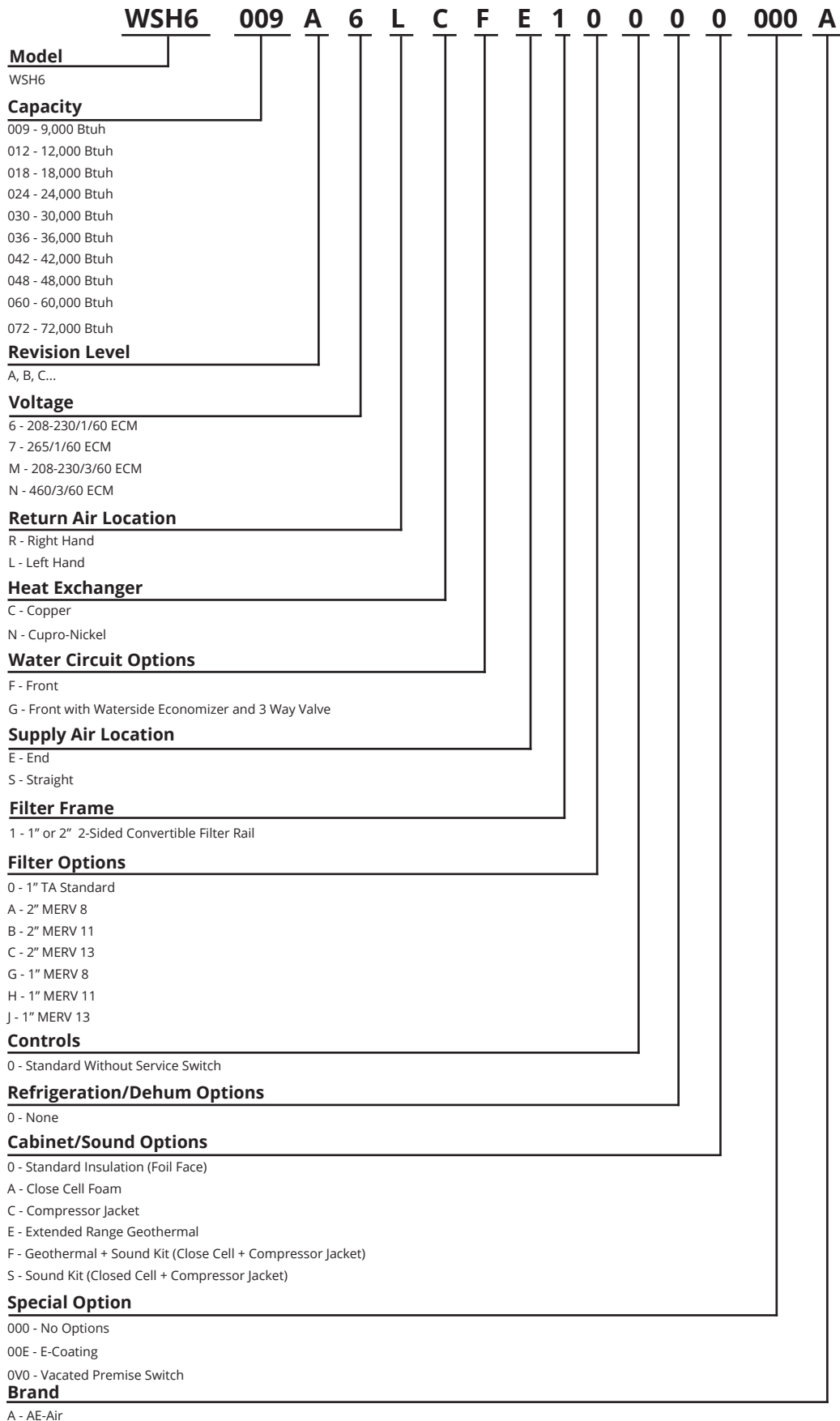

# WSH6 WATER SOURCE HEAT PUMP

AE-Air is proud to announce the release of the HydroTech WSH6, our premium high efficiency, geothermal unit, available in sizes 0.75 to 6 tons. ENERGY STAR certified for ground water and ground loop applications.

The HydroTech WSH6 series water to air heat pump is designed from the ground up to address the needs of architects, owners, and contractors. It provides the best combination of performance, efficiency and reliability in a compact design. The WSH6 series comes standard with ECM blower motors for high efficiency and comfort.

All WSH6 models feature double compressor vibration isolation for quiet operation, easy to remove blower housing for quick service, as well as a single compressor designs to maximize reliability and improve serviceability.

## WSH6

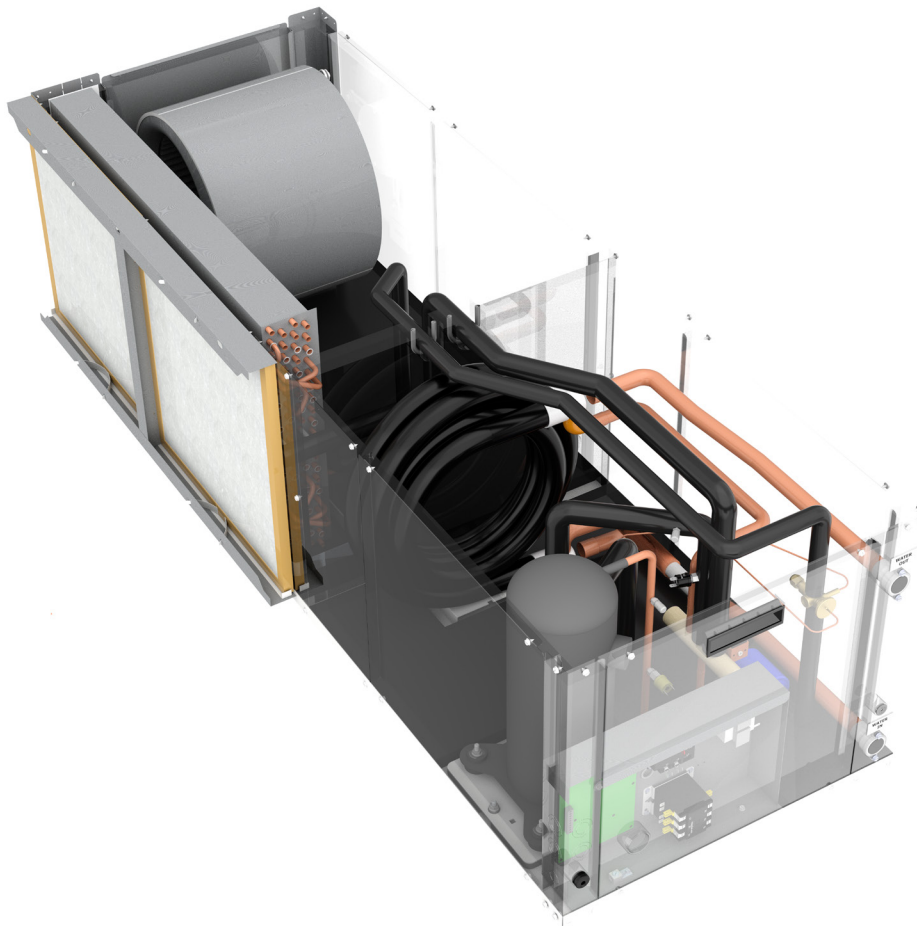

## STANDARD FEATURES

- 100% Factory Tested
- R-454B Refrigerant - All units operate with environmentally friendly R-454B refrigerant.
- Non-corrosive thermoplastic condensate pan-sloped for positive drainage.
- Superior insulation: Fully insulated cabinet with 1" foil face insulation for the air handling section, and 1" Tuf-Skin insulation for the compressor section.
- High and low pressure service ports
- Refrigerant filter-drier
- Panel-mounted FPT water connections - no back-up wrench needed.
- 50 VA Transformer
- 1" to 2" Convertible filter rail
- Water Coil Freeze Sensor
- Air coil freeze sensor
- Condensate overflow sensor
- Digital Diagnostic Display - A two-digit display indicates either the current operational mode or a fault code thru-the-door site glass to read display
- 24V Status LED - Green light indicates 24V power to the control module
- Nuisance Trip Protection - Unit will attempt to start up to three times with a fault signal. If the fault continues, the unit locks out.
- Over/Under voltage protection
- Random sequencing start timer
- Test Mode with LED Indicator - Speeds up control timers for service personnel
- Alarm Relay - Activated

## OPTIONAL FEATURES

- Cupronickel coaxial heat exchanger
- Vacated premises control - Allows the unit to operate for either 1 or 2 hours per day (total) during extended periods of unoccupancy (requires optional kit).
- E-Coated air coil corrosion protection
- Sound attenuation kit
- Extended range (Geothermal)
- Waterside Economizer

# WSH6 WATER SOURCE HEAT PUMP

## DIGITAL CONTROL MODULE

Controls unit operation and monitors all safety controls. (Patent Pending)

### Standard Features

- Digital Diagnostic Display - A two-digit display indicates either the current operational mode or a fault code
- 24V Status LED - Green light indicates 24V power to the control module
- Nuisance Trip Protection - Unit will attempt to start up to three times with a fault signal. If the fault continues, the unit locks out.
- Condensate Overflow Lockout
- High and low Pressure Controls
- Water Coil Low Temperature Protection
- Over / Under Voltage Protection
- Random sequencing start timer
- Anti-short Cycle Timer
- Test Mode with LED Indicator - Speeds up control timers for service personnel
- Alarm Relay - Activated if the unit locks out
- Conformal Coating on both sides of control board for humidity and condensation protection

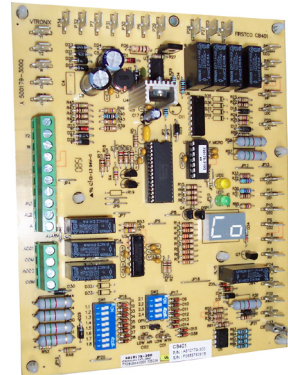

Electronic Control Module



DESCRIPTION OF OPERATION	LED Readout
NORMAL MODE	ON (Green Light)
CONTROL (OR) HIGH PRESSURE	High (Green Light)
TEST MODE (plus locked momentary)	ON (Yellow Light)
BLUETOOTH	ON
FAULT (or action)	Flashes
COOL (or 45 Sec)	ON
HEAT (or 10 Sec)	ON
ACCESSORY RELAY 1	ON
ACCESSORY RELAY 2	ON
WATER COIL LOW TEMP	ON
FAULT RELAY	ON (V.O.C. #)
LOCKOUT	ON (V.O.C. #)
OVER / UNDER VOLTAGE SHUTDOWN	ON (V.O.C. #)
TEMPERATURE SENSING ERROR	ON (V.O.C. #)
TEST MODE - NO FAULT	CODE 11
TEST MODE - HP FAULT	CODE 12
TEST MODE - LP FAULT	CODE 13
TEST MODE - COIL FAULT	CODE 14
TEST MODE - WCO FAULT	CODE 15
TEST MODE - COND. OVERFLOW FAULT	CODE 16
TEST MODE - OVER/UNDER SHUTDOWN	CODE 17
TEST MODE - WATERSIDE/VALVE/TEMPERATURES	CODE 18
TEST MODE - TRIP/REPEAT SENSING ERROR	CODE 19

Sight Glass on Door



Thermoplastic Drain Pan



Optional Vacated Premises Selector Switch

### Dip Switches (field selectable settings):

- 5 Second Compressor Delay - Blower starts before the compressor, which helps attenuate compressor start up sound.
- 45 Second Blower-off Delay - Increases cooling efficiency.
- Continuous Dehumidification Mode - Selects continuous low speed fan operation for increased humidity removal.
- VPC Switch - Selects either one or two hour daily operation (requires optional kit)
- Lower Water and Air Coil Temperature Cutout Options - Optional 10 degree F. cutouts for applications where water temperature is below 50 degrees F. (requires antifreeze solution).
- Two Accessory Relays - The relays can cycle with either the fan or compressor. In addition, relay number one can be configured for use with slow opening water valves (60 second pre-compressor initialization) and relay number 2 can be configured for a 30 second post fan delay.

# PHYSICAL DATA

Model		Size									
		9	12	18	24	30	36	42	48	60	72
<b>Compressor (1 Each)</b>		Rotary				Scroll					
<b>Refrigerant Type</b>		R454B									
<b>Factory Charge (oz) [kg]</b>		22.2 [0.63]	32.5 [0.92]	42.5 [1.21]	50.9 [1.44]	54.1 [1.53]	62.1 [1.76]	86.1 [2.44]	80.9 [2.29]	100.3 [2.84]	138.9 [3.94]
<b>Motor</b>	<b>Type</b>	ECM									
	<b>Speeds</b>	Up to 4 Speed Taps Available									
	<b>HP [kw]</b>	1/4 [.18]	1/4 [.18]	1/3 [.24]	1/2 [.37]*	1/2 [.37]*	1/2 [.37]*	3/4 [.56]	3/4 [.56]	1 [0.75]	1 [0.75]
<b>Blower Wheel Size (Dia x W) in. [mm]</b>		6.75 x 7 [171 x 178]		9 x 7 [229 x 178]	9 x 8 [229 x 203]	10 x 8 [254 x 203]		10 x 10 [254 x 254]	11 x 10 [279 x 254]		
<b>COAX Volume (US Gallons) [liters]</b>		0.116 [0.44]	0.144 [0.55]	0.238 [0.90]	0.359 [1.36]	0.432 [1.64]	0.533 [2.02]	0.624 [2.36]	0.88 [3.33]	0.88 [3.33]	1.084 [4.10]
<b>Water Connection FTP (in)</b>		3/4	3/4	3/4	3/4	3/4	3/4	1	1	1	1
<b>Condensate Connection FTP (in)</b>		3/4	3/4	3/4	3/4	3/4	3/4	3/4	3/4	3/4	3/4
<b>Air Coil Dimension (H x L) (in) [mm]</b>		16 x 15.5 [406 x 394]		16 x 22 [406 x 559]	20 x 25 [508 x 635]			20 x 35 [508 x 889]		20 x 45 [508 x 1143]	
<b>Standard TA Filter 1" [25.4mm] (in) [mm]</b>		16 x 20 [406 x 508]		16 x 25 [406 x 635]	20 x 30 [508 x 762]			20 x 20 [508 x 508]		20 x 25 [508 x 635]	
<b>Filter Qty</b>		1	1	1	1	1	1	2	2	2	2
<b>Operating Weight lbs [kg]</b>		137 [62.2]	142 [64.4]	189 [85.8]	245 [111.2]	254 [115.3]	271 [123]	335 [152]	356 [161.5]	365 [165.6]	404 [183.3]
<b>Shipping Weight lbs [kg]</b>		159 [72.2]	164 [74.4]	214 [97.1]	289 [131.1]	289 [131.1]	306 [138.8]	378 [171.5]	399 [181]	408 [185.1]	450 [204.2]
<b>Operating Weight with Economizer option lbs [kg]</b>		-	-	-	-	-	-	410 [186]	432 [196]	440 [200]	515 [234]
<b>Shipping Weight with Economizer option lbs [kg]</b>		-	-	-	-	-	-	453 [206]	474 [216]	483 [220]	550 [250]

NOTE: \*3/4HP for 460V Models

# PERFORMANCE DATA

Model	Rated Airflow	GPM	Water Loop (Entering Water Temperature)			
			86°F		68°F	
			Cooling	EER	Heating	COP
WSH6009	350	3.0	9,000	16.0	10,000	5.1
WSH6012	450	3.0	12,000	16.0	13,500	5.4
WSH6018	600	4.5	18,000	16.0	20,000	5.0
WSH6024	850	6.0	25,000	16.0	25,700	5.0
WSH6030	1025	7.5	29,000	16.0	32,000	5.0
WSH6036	1050	9.0	36,000	16.0	41,500	4.6
WSH6042	1400	10.5	42,000	16.0	47,000	5.0
WSH6048	1500	12.0	48,000	16.0	56,500	4.8
WSH6060	1750	15.0	60,000	16.0	67,000	4.8
WSH6072	2100	18.0	72,000	15.3	86,000	4.3

Model	Rated Airflow	GPM	Ground Water (Entering Water Temperature)			
			59°F		50°F	
			Cooling	EER	Heating	COP
WSH6009	350	3.0	10,000	23.0	8,500	4.2
WSH6012	450	3.0	12,500	23.1	11,000	4.6
WSH6018	600	4.5	20,500	26.0	16,000	4.3
WSH6024	850	6.0	28,500	30.0	22,000	5.0
WSH6030	1025	7.5	33,000	29.0	26,000	4.7
WSH6036	1050	9.0	39,000	23.2	34,000	4.1
WSH6042	1400	10.5	44,500	23.3	40,000	4.3
WSH6048	1500	12.0	53,000	23.6	46,000	4.2
WSH6060	1750	15.0	67,000	23.5	55,500	4.3
WSH6072	2100	18.0	79,000	21.8	69,000	4.1

Model	Rated Airflow	GPM	Ground Loop (Entering Water Temperature)			
			77°F		32°F	
			Cooling	EER	Heating	COP
WSH6009	350	3.0	9,500	18.9	6,800	3.6
WSH6012	450	3.0	12,000	18.2	8,500	3.8
WSH6018	600	4.5	19,000	19.0	12,000	3.6
WSH6024	800	6.0	26,000	23.0	17,700	4.2
WSH6030	1025	7.5	30,000	20.0	21,000	4.7
WSH6036	1050	9.0	36,500	18.0	27,000	3.6
WSH6042	1400	10.5	43,000	18.5	31,500	3.8
WSH6048	1500	12.0	49,500	18.1	36,000	3.6
WSH6060	1750	15.0	62,500	18.1	45,000	3.6
WSH6072	2100	18.0	73,000	17.1	55,000	3.6

Cooling capacities based on 80.6°F DB, 66.2°F WB entering air temperature  
 Heating capacities based on 68°F DB, 59°F WB entering air temperature  
 All ratings based upon operation at lower voltage of dual voltage rated models

# ECONOMIZER PERFORMANCE DATA

Model	Rated Air Flow	GPM	Cooling Capacity (Btu/Hr)
WSH6042-ECO	1400	10.5	40,000
WSH6048-ECO	1500	12.0	44,000
WSH6060-ECO	1750	15.0	51,000
WSH6072-ECO	2100	18.0	62,500

Cooling capacities for Economizer based on 80.6°F DB, 66.2°F WB entering air temperature and 45°F entering water temperature. All ratings based upon operation at lower voltage of dual voltage rated models



# ECONOMIZER PERFORMANCE DATA

Size	EWT	EAT (dbt/wbt)	CFM	GPM	Total Capacity	Sensible Capacity
042	45	80.6 / 66.2	1050	5.3	20,516	20,087
			1225		24,335	24,335
			1400		26,103	26,103
			1050	7.9	27,750	22,812
			1225		31,987	28,079
			1400		33,587	30,896
			1050	10.5	31,829	24,499
			1225		37,610	30,409
			1400		40,033	33,413
048	45	80.6 / 66.2	1200	6	25,745	25,509
			1500		28,990	28,990
			1600		29,967	29,967
			1200	9	34,176	28,674
			1500		37,481	33,467
			1600		38,301	35,028
			1200	12	39,592	30,893
			1500		44,152	36,155
			1600		45,419	37,776
060	45	80.6 / 66.2	1500	7.50	31,509	30,465
			1750		33,703	33,703
			2000		36,218	36,218
			1500	11.30	41,307	34,133
			1750		44,051	38,111
			2000		41,724	41,680
			1500	15.00	47,202	36,547
			1750		51,058	40,784
			2000		54,249	44,684
072	45	80.6 / 66.2	1800	9	42,011	39,173
			2100		44,177	43,836
			2400		47,387	47,387
			1800	13.5	52,780	43,529
			2100		56,426	48,517
			2400		59,496	53,069
			1800	18	59,896	46,105
			2100		62,500	51,623
			2400		68,949	56,591

# AIRFLOW DATA

Model	Fan Speed	Rated Airflow	CFM VS. External Static Pressure (in. wg)									
			0.1	0.2	0.3	0.4	0.5	0.6	0.7	0.8	0.9	1.0
WSH6009	WHITE	350 - T3	-	-	370	340	310	280	250	-	-	-
	VIOLET		-	370	340	310	280	250	-	-	-	
	GRAY		375	350	320	290	260	-	-	-	-	
WSH6012	WHITE	450 - T3	-	-	470	440	410	380	350	320	-	-
	VIOLET		-	460	430	400	370	340	310	-	-	
	GRAY		440	410	380	350	320	-	-	-	-	
WSH6018	T4	600 - T3	-	-	-	-	675	650	600	530	490	-
	T3		-	-	-	675	630	590	540	480	-	
	T2		-	-	660	620	570	540	490	-	-	
	T1		675	650	610	560	510	480	-	-	-	
WSH6024	T4	850 - T3	-	-	-	-	920	880	840	810	780	720
	T3		-	-	-	900	860	820	790	760	720	
	T2		-	-	890	840	800	760	730	690	-	
	T1		-	880	830	770	740	710	680	-	-	
WSH6030	T4	1025 - T3	-	-	-	-	1,170	1,050	950	850	750	-
	T3		-	-	1,160	1,130	1,090	1,000	900	800	-	
	T2		1,130	1,090	1,060	1,030	990	940	850	-	-	
	T1		1,030	1,000	970	940	900	860	-	-	-	
WSH6036	T3	1050 - T3	-	1,380	1,350	1,310	1,200	1,090	1,000	900	-	-
	T2		1,330	1,280	1,240	1,200	1,140	1,030	930	-	-	
	T1		1,240	1,190	1,160	1,130	1,090	970	-	-	-	
WSH6042	T4	1400 - T3	-	-	-	-	1,570	1,530	1,500	1,470	1,440	1,350
	T3		-	1,550	1,520	1,490	1,460	1,430	1,400	1,370	1,340	
	T2		1,450	1,420	1,390	1,360	1,330	1,300	1,260	1,230	1,200	
	T1		1,380	1,350	1,320	1,290	1,260	1,230	1,200	1,170	-	
WSH6042 - Economizer	T4	1400 - T3	-	-	-	-	-	-	-	1,567	1,354	982
	T3		-	-	-	-	-	1,601	1,568	1,480	1,289	
	T2		-	1,571	1,536	1,509	1,490	1,473	1,440	1,364	1,211	
	T1		1,540	1,508	1,473	1,444	1,425	1,408	1,379	1,315	1,184	
WSH6048	T4	1500 - T3	-	-	-	-	1,760	1,700	1,540	1,430	1,300	1,200
	T3		-	1,750	1,720	1,690	1,660	1,610	1,500	1,400	1,300	
	T2		1,700	1,640	1,600	1,570	1,540	1,510	1,450	1,370	-	
	T1		1,560	1,520	1,490	1,460	1,420	1,380	1,330	-	-	
WSH6048 - Economizer	T4	1500 - T3	-	-	-	1,720	1,612	1,494	1,372	1,253	1,146	1,056
	T3		-	-	1,772	1,689	1,589	1,479	1,364	1,251	1,148	
	T2		1,757	1,734	1,688	1,623	1,541	1,449	1,348	1,244	1,141	
	T1		1,638	1,613	1,578	1,533	1,478	1,412	1,336	1,247	1,146	

NOTE: Airflow data shown is with a wet coil at 80°F DB, 67°F WB EAT and with standard 1" MERV 8 filter

# AIRFLOW DATA

Continued

Model	Fan Speed	Rated Airflow	CFM VS. External Static Pressure (in. wg)									
			0.1	0.2	0.3	0.4	0.5	0.6	0.7	0.8	0.9	1.0
WSH6060	T4	1750 - T2	-	-	-	-	2,240	2,210	2,150	2,080	2,000	1,900
	T3		2,240	2,210	2,180	2,150	2,100	2,070	2,030	1,970	1,920	1,830
	T2		2,100	2,060	2,030	2,000	1,960	1,920	1,880	1,870	1,830	1,760
	T1		1,940	1,910	1,880	1,840	1,790	1,750	1,710	1,680	-	-
WSH6060 - Economizer	T4	1750 - T2	2,149	2,061	1,961	1,849	1,722	1,579	1,417	-	-	-
	T3		2,115	2,038	1,943	1,831	1,703	1,560	1,403	-	-	-
	T2		2,016	1,961	1,887	1,794	1,681	1,549	1,396	-	-	-
	T1		1,884	1,836	1,783	1,718	1,635	1,527	1,389	-	-	-
WSH6072	T3	2100 - T3	2,420	2,380	2,360	2,320	2,260	2,240	2,210	2,130	2,040	1,960
	T2		2,290	2,250	2,220	2,180	2,140	2,110	2,070	2,010	1,950	-
	T1		2,160	2,120	2,090	2,040	2,010	1,970	1,940	-	-	-
WSH6072 - Economizer	T3	2100 - T3	2,265	2,215	2,154	2,083	2,003	1,917	1,825	1,729	1,629	1528
	T2		2,219	2,178	2,123	2,057	1,982	1,898	1,808	1,714	1,617	1,520
	T1		2,111	2,083	2,044	1,995	1,937	1,869	1,793	1,709	1,618	1,520

NOTE: Airflow data shown is with a wet coil at 80°F DB, 67°F WB EAT and with standard 1" MERV 8 filter

# ELECTRICAL DATA

Model	Voltage	Compressor		Blower		MCA	MOP
		RLA	LRA	FLA	HP		
WSH6009	208/230V-1-60	3.7	22	2.3	1/4	7	15
	265V-1-60	3.5	22	2.3	1/4	7	15
WSH6012	208/230V-1-60	4.7	26	2.3	1/4	9	15
	265V-1-60	3.8	23	2.3	1/4	8	15
WSH6018	208/230V-1-60	7	38	2.8	1/3	12	15
	265V-1-60	6	30	2.6	1/3	11	15
WSH6024	208/230V-1-60	16.8	55	4.6	1/2	26	40
	265V-1-60	9.6	54	3.6	1/2	16	25
	208/230V-3-60	7.7	55.4	4.6	1/2	15	20
	460V-3-60	3.6	28	3.2	3/4	8	15
WSH6030	208/230V-1-60	12.8	67.8	4.6	1/2	21	30
	265V-1-60	10.9	60	3.6	1/2	18	25
	208/230V-3-60	8.3	58	4.6	1/2	15	20
	460V-3-60	4	38	3.2	3/4	9	15
WSH6036	208/230V-1-60	15.4	83.9	4.6	1/2	24	35
	265V-1-60	13.5	72	3.6	1/2	21	30
	208/230V-3-60	10.4	73	4.6	1/2	18	25
	460V-3-60	5.8	38	3.2	3/4	11	15
WSH6042	208/230V-1-60	19.2	123.9	6.3	3/4	31	45
	265V-1-60	16	87	4.9	3/4	25	40
	208/230V-3-60	13.5	88	6.3	3/4	24	35
	460V-3-60	6	44	3.2	3/4	11	15
WSH6048	208/230V-1-60	19.6	130	6.3	3/4	31	50
	265V-1-60	16.3	98	4.9	3/4	26	40
	208/230V-3-60	13.7	83.1	6.3	3/4	24	35
	460V-3-60	6.2	41	3.2	3/4	11	15
WSH6060	208/230V-1-60	24.4	144.2	7.6	1	39	60
	265V-1-60	19.9	130	6.6	1	32	50
	208/230V-3-60	16	110	7.6	1	28	40
	460V-3-60	7.8	52	4	1	14	20
WSH6072	208/230V-1-60	30.8	178	7.6	1	47	70
	208/230V-3-60	19.6	136	7.6	1	33	50
	460V-3-60	8.2	66.1	4	1	15	20

## WATER PRESSURE DROP

WSH6009	Flow Rate (GPM)	1.1	1.7	2.3
	Pressure Drop (PSI)	0.2	0.7	1.2
WSH6012	Flow Rate (GPM)	1.5	2.5	3.0
	Pressure Drop (PSI)	0.5	1.5	2.0
WSH6018	Flow Rate (GPM)	2.3	3.4	4.5
	Pressure Drop (PSI)	0.5	1.4	2.4
WSH6024	Flow Rate (GPM)	3.0	4.5	6.0
	Pressure Drop (PSI)	0.3	1.1	2.0
WSH6030	Flow Rate (GPM)	3.8	5.6	7.5
	Pressure Drop (PSI)	1.0	2.1	3.5
WSH6036	Flow Rate (GPM)	4.5	6.8	9.0
	Pressure Drop (PSI)	0.3	1.3	2.4
WSH6042	Flow Rate (GPM)	5.3	7.9	10.5
	Pressure Drop (PSI)	0.3	1.6	2.8
WSH6048	Flow Rate (GPM)	6.0	9.0	12.0
	Pressure Drop (PSI)	1.1	2.2	3.5
WSH6060	Flow Rate (GPM)	7.5	11.3	15.0
	Pressure Drop (PSI)	1.4	3.2	5.3
WSH6072	Flow Rate (GPM)	9.0	13.5	18.0
	Pressure Drop (PSI)	1.6	3.0	5.1

All values based on pure water at 70°F

## WATER PRESSURE DROP

*with Economizer Option*

WSH6042-ECO	Flow Rate (GPM)	5.3	7.9	10.5
	Eco. Coil Press. Drop (PSI)	0.26	0.64	1.08
	System Press. Drop (PSI)	1.55	3.35	5.64
WSH6048-ECO	Flow Rate (GPM)	6.0	9.0	12.0
	Eco. Coil Press. Drop (PSI)	0.42	0.80	1.32
	System Press. Drop (PSI)	2.1	4.3	7.4
WSH6060-ECO	Flow Rate (GPM)	7.5	11.3	15.0
	Eco. Coil Press. Drop (PSI)	0.54	1.17	1.93
	System Press. Drop (PSI)	3.13	6.76	11.82
WSH6072-ECO	Flow Rate (GPM)	9.0	13.5	18.0
	Eco. Coil Press. Drop (PSI)	1.01	2.06	3.45
	System Press. Drop (PSI)	5.3	9.8	17.2

# DIMENSIONS

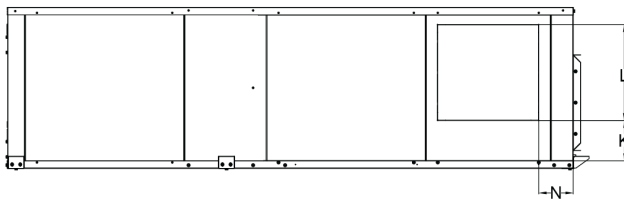
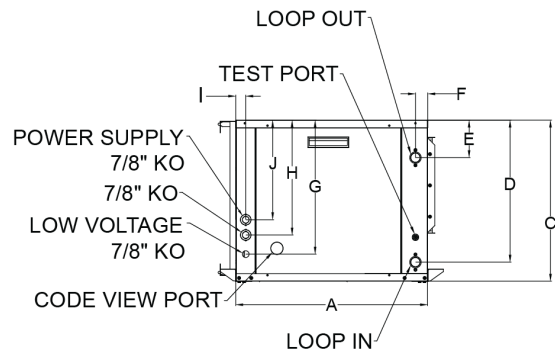
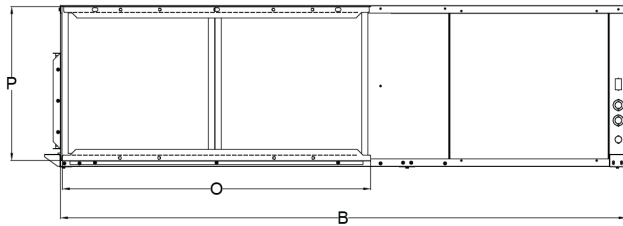
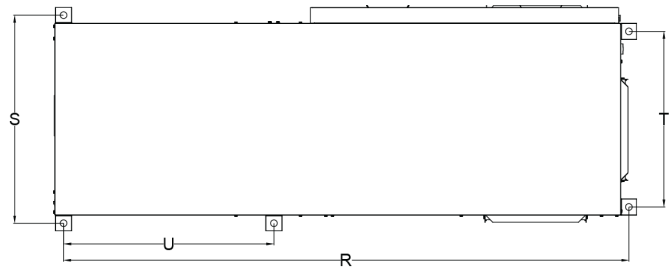
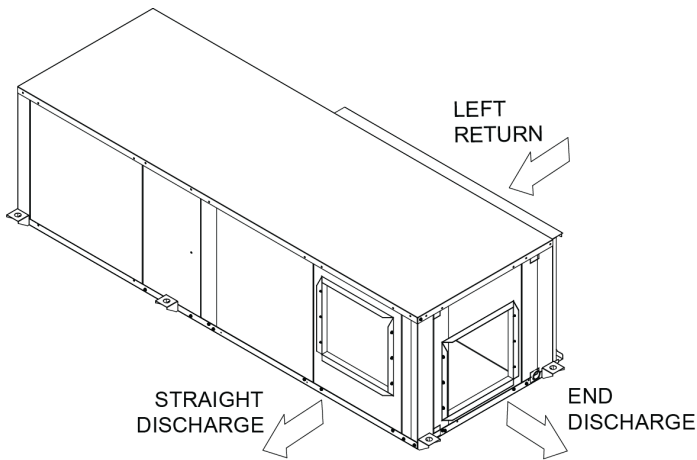

LEFT RETURN STRAIGHT DISCHARGE

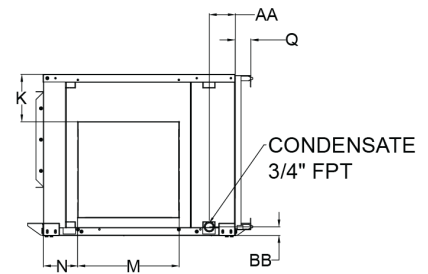

LEFT RETURN END DISCHARGE

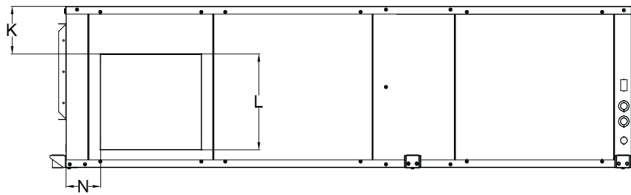

RIGHT RETURN STRAIGHT DISCHARGE

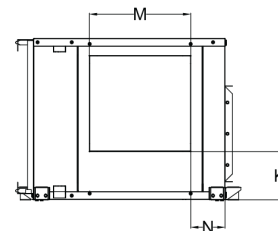

RIGHT RETURN END DISCHARGE

# DIMENSIONS

Model	Overall Cabinet			Water Connections			Loop In/Out FTP	Electrical Knockouts			
	Width	Depth	Height	Loop In/Out				G	H	I	J
	A	B	C	D	E	F					
WSH6009	22.1	41.1	17	14.6	4.9	1.6	3/4	1.5	11	1.2	9
WSH6012	22.1	41.1	17	14.6	4.9	1.6	3/4	1.5	11	1.2	9
WSH6018	22.1	48.1	17	14.6	4.9	1.6	3/4	1.5	11	1.2	9
WSH6024	25.1	60.1	21	18.6	4.9	1.6	3/4	17.5	15	1.2	13
WSH6030	25.1	60.1	21	18.6	4.9	1.6	3/4	17.5	15	1.2	13
WSH6036	25.1	60.1	21	18.6	4.9	1.6	3/4	17.5	15	1.2	13
WSH6042	25.1	74.1	21	18.6	4.9	1.6	1	17.5	15	1.2	13
WSH6048	25.1	74.1	21	18.6	4.9	1.6	1	17.5	15	1.2	13
WSH6060	25.1	74.1	21	18.6	4.9	1.6	1	17.5	15	1.2	13
WSH6072	25.1	84.1	21	18.6	4.9	1.6	1	17.5	15	1.2	13

Model	Discharge Duct Flange				Return Duct Flange			Mounting Brackets Center Distances				Condensate 3/4" FTP	
	K	L	M	N	O	P	Q	R	S	T	U	AA	BB
WSH6009	10.1	3.9	9	5.6	20	16.2	2	41	24.2	19.9	-	3.4	1.1
WSH6012	10.1	3.9	9	5.6	20	16.2	2	41	24.2	19.9	-	3.4	1.1
WSH6018	4.6	11.4	9.7	4.8	25	16.2	2	48	24.2	19.9	-	3.4	1.1
WSH6024	6.9	11.5	10.7	5.7	30	20.3	2	60	27.2	22.9	-	3.4	1.1
WSH6030	6.9	11.5	10.7	5.7	30	20.3	2	60	27.2	22.9	-	3.4	1.1
WSH6036	6.9	11.5	10.7	5.7	30	20.3	2	60	27.2	22.9	-	3.4	1.1
WSH6042	7.4	11.5	10.7	5.7	40	20.3	2	74	27.2	22.9	27.5	3.4	1.1
WSH6048	7.4	11.5	13.1	4.6	40	20.3	2	74	27.2	22.9	27.5	3.4	1.1
WSH6060	6	12.5	13.3	4.5	40	20.3	2	74	27.2	22.9	27.5	3.4	1.1
WSH6072	6	12.5	13.3	4.5	50	20.3	2	84	27.2	22.9	27.5	3.4	1.1

In keeping with its policy of continuous progress and product improvement, First Co. reserves the right to make changes without notice.

# DIMENSIONS

*Economizer Options*

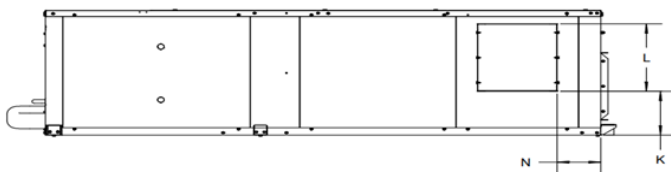
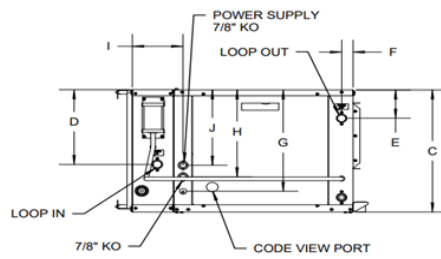
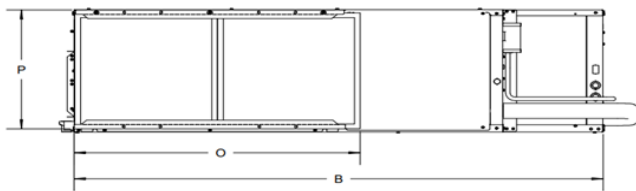
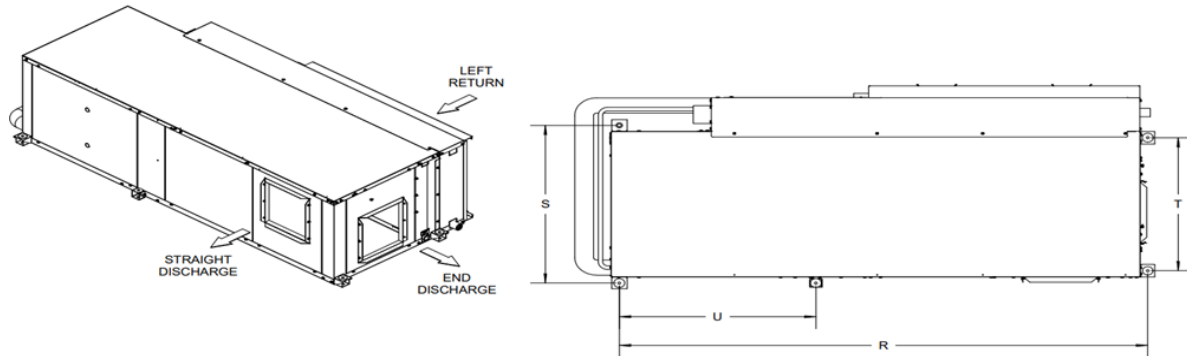

LEFT RETURN STRAIGHT DISCHARGE

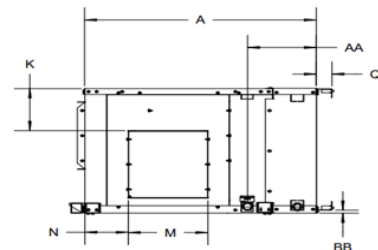

LEFT RETURN END DISCHARGE

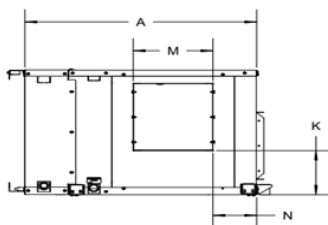

RIGHT RETURN END DISCHARGE

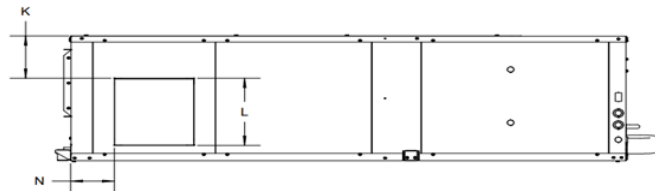

RIGHT RETURN STRAIGHT DISCHARGE



# DIMENSIONS

## Economizer Options

Model	Overall Cabinet			Water Connections			Loop In/Out FTP	Electrical Knockouts			
	Width	Depth	Height	Loop In/Out				G	H	I	J
	A	B	C	D	E	F					
WSH6042-ECO	31.0	74.1	21	12.9	4.9	1.6	1.0	17.5	15	7.1	13
WSH6048-ECO	31.0	7.4	21	12.9	4.9	1.6	1.0	17.5	15	7.1	13
WSH6060-ECO	31.0	7.4	21	12.9	4.9	1.6	1.0	17.5	15	7.1	13
WSH6072-ECO	31.0	84.1	21	12.9	4.9	1.6	1.0	17.5	15	7.1	13

Model	Discharge Duct Flange				Return Duct Flange			Mounting Brackets Center Distances				Condensate 3/4" FTP	
	K	L	M	N	O	P	Q	R	S	T	U	AA	BB
WSH6042-ECO	7.4	11.5	10.7	5.7	40	20.3	2	74	27.2	22.9	27.5	9.2	0.5
WSH6048-ECO	7.4	11.5	13.1	4.6	40	20.3	2	74	27.2	22.9	27.5	9.2	0.5
WSH6060-ECO	6.0	12.4	13.3	4.5	40	20.3	2	74	27.2	22.9	27.5	9.2	0.5
WSH6072-ECO	6.0	12.5	13.3	4.5	50	20.3	2	84	27.2	22.9	27.5	9.2	0.5

## GUIDE SPECIFICATION

### GENERAL

Equipment is completely assembled, piped, internally wired, fully charged with R454B refrigerant and factory tested. Filters, thermostat field interfaces, and all safety controls are factory installed.

Units shall be capable of operating over entering fluid temperature ranges of 50°- 110° in cooling mode and 50°- 90° in heating mode in standard configuration.

For Economizer option; entering fluid temperature ranges can be 35°- 110°.

## UNIT CONSTRUCTION

### CONFIGURATIONS

Horizontal units are configurable in the following arrangements: left return/end discharge, left return/side discharge, right return/end discharge, right return/side discharge.

For all systems, water, refrigerant and electrical connections are accessible from the front service access panel.

### CABINET CONSTRUCTION

Units are built with a corner post and base design using a minimum of 18 gauge galvanized steel on any weight bearing component. Corner posts and panels are designed to allow for service access to all internal components. Structural integrity of the cabinets is unaffected by the removal of any or all of the access panels.

Air handling section interior surfaces are lined with 1" thick foil faced insulation. The insulation is placed such that there is no exposed section of the fiberglass fibers into the airstream.

The condensing section interior surfaces are lined with 1" on the condensing section base pan, mid pan, and all lower access panels.

# GUIDE SPECIFICATION

## SERVICE CONNECTIONS

Water connections are accessible from the front of the unit. Water connections shall be made through factory installed brass FPT fittings which will be flush to the water panel. The water fittings shall be rigidly attached to the corner posts to forgo the use of a backup wrench when connecting the supply water.

## SUPPLY AIR CONNECTIONS

Horizontal systems have 1" integral supply duct collars to allow for connection of the supply duct. All duct collars are installed on the unit from the factory.

## DRAIN PAN

All units, except WSH6072 (stainless steel), use a thermoplastic drain pan to increase corrosion resistance with the drain pan port located near the back of the unit. The drain pan will be internally two-way sloped, with the drain port located near the front of the unit. The unit comes standard with an electronic condensate overflow sensor attached to the edge of the drain pan.

Economizer option has a 2nd drain pan with 2nd condensate overflow sensor attached.

# REFRIGERATION CIRCUIT

## GENERAL

All systems use R454B refrigerant. All units have factory charged refrigeration circuits, each with its own compressor, reversing valve, bi-flow TXV, coaxial heat exchanger and finned tube refrigerant to air heat exchanger. Each circuit includes a high pressure switch, low pressure switch, and heat exchanger freeze sensors. The circuits each have a high-side and low-side Schrader valve to allow for service access to the refrigeration systems. All service ports are accessible from the front of the unit.

## COMPRESSOR

All systems use a high efficiency compressor. The scroll compressor is attached to a 12 gauge double-isolated compressor mounting plate to dampen vibration throughout the system.

For additional sound attenuation, an optional sound package is available which offers a compressor blanket.

## COAXIAL HEAT EXCHANGER

The systems use one high efficiency coaxial heat exchanger. The coaxial heat exchanger is designed for working refrigerant pressures up to 600psi and working water pressures up to 400psi. The heat exchanger is coated in an epoxy resin to protect against corrosion.

Optional cupro-nickel coaxial heat exchangers are offered to provide additional corrosion resistance in certain hard water and open loop applications.

## REVERSING VALVE

A system reversing valve (4-way valve) is included with all heat pump systems. The valve is piped to be energized in cooling mode to provide heat if a valve failure were to occur. Once the valve is energized in cooling mode, it will remain energized as long as the "O" call is provided to the unit control board.

## THERMOSTATIC EXPANSION VALVE

Each independent refrigeration circuit has its own balanced port, externally equalized bi-flow thermostatic expansion valve. The thermostatic expansion valve has sweat connections on the inlet/outlet and feature a screw on equalizer port connection.

## EVAPORATOR COIL

Internally finned, 3/8-inch copper tubes mechanically bonded to a configured aluminum finned plate is standard. Coils are leak tested at the factory to ensure the pressure integrity. The coils are leak tested to 450 psig and pressure tested

## GUIDE SPECIFICATION (Cont.)

### ELECTRICAL AND CONTROLS

VPC (Vacated Premises Control) - Allows the unit to operate for either 1 or 2 hours a day (total) during extended periods of un-occupancy (requires optional kit).

Nuisance Trip Protection - Unit will attempt to start up to three times with a fault signal. If the fault continues, the unit locks out.

#### Dip Switches (field selectable settings):

- 5 Second Compressor Delay- Blower starts before the compressor, which helps attenuate compressor start up sound.
- 45 Second Blower Off Delay - Increases cooling efficiency.
- VPC Switch - Selects either one or two hour daily operation (requires optional kit).
- Lower Water and Air Coil Temperature Cutout Options - Optional 10°F cutouts for applications where water temperature is below 50°F (requires antifreeze solution).
- Two Accessory Relays - The relays can cycle with either the fan or compressor. In addition, relay number one can be configured for use with a slow opening water valves (60 second pre-compressor initialization) and relay number two can be configured for a 30 second post fan delay.

### GENERAL

All units have a control box mounted in the condensing section compartment which houses all necessary electrical components for unit operation. This control box serves as the location for wiring of the high voltage and low voltage circuits for unit operation.

The unit is controlled via 24V low voltage terminals, which connects to an external thermostat or controller which will control the heating and cooling provided by the unit.

The electrical control box contains the following components.

1. Compressor Contactors
2. Blower motor contactors
3. Control Board
4. Low Voltage Wiring Connections
5. High Voltage terminal block
6. 24V Transformer for low voltage control
7. Phase monitor

### WATER SOURCE CONTROL MODULE

All units will come standard with a WSCM electromechanical module that will control unit operation and contain safety features to protect the compressors, coaxial heat exchangers and fin-tube heat exchangers. The board will contain the following features:

1. Single cooling and Single heating control modes for optimal temperature and pressure control
2. Anti-short cycle protection
3. Random sequencing start timer
4. High and Low Pressure Safeties
5. Water Coil Freeze Protection
6. Air-coil Freeze protection
7. Over/under voltage protection
8. Fault Retry
9. Lockout with soft and hard reset
10. Condensate overflow sensor
11. Diagnostic LED display
12. Test Mode
13. Alarm Relay
14. Accessory Relays

### UNIVERSAL TEMPERATURE CONTROLLER (ECONOMIZER OPTION)

Economizer option comes with a universal temperature controller, which continuously monitors incoming fluid temperatures. Shall incoming fluid temperature falls to 50°F OF or below, in cooling mode, it deactivates compressor and turn on motorized 3-way valve, which directs fluid flow to Economizer coil. In Economizer mode all cooling comes from Economizer, saving energy.

### MOTORIZED 3-WAY VALVE (ECONOMIZER OPTION)

Economizer option comes with a motorized 3-way valve, factory wired, which automatically directs fluid to Economizer or



AE-Air  
P.O. Box 270969 - Dallas, Texas 75227  
Ph. (214) 388-5751 | Fax (214) 388-2255  
[www.ae-air.com](http://www.ae-air.com)

MAY 2024