



VCB / VFB / VSB / WCB

Vertical Floor Consoles

Concealed Model – VCB

Flat Top – VFB

Slope Top – VSB

Recessed Wall – WCB

277V option available

220V, 50Hz models available (non ETL)



NOMENCLATURE

12 **VC** **B** **0** - **126** - **31** **R** - **2B** - **N1**

CFM (100'S)

3,4,6,8,10,12

Unit Style

VC - Concealed
VS - Cabinet slope top
VF - Cabinet flat top
VCX - Concealed with ECM motor
VSX - Cabinet slope top with ECM motor
VFX - Cabinet flat top with ECM Motor

Vintage

B

Unit Voltage

126 - 120V-1PH-60Hz
246 - 208/230V-1PH-60Hz
225 - 220V-1PH-50Hz
276 - 277V-1PH-60Hz

Coil Type

3 - 3 row
4 - 4 row
31 - 3 row cool, 1 row heat
41 - 4 row cool, 1 row heat (available on 300-800 CFM only)

Coil Connection

R - Right Hand (Facing Unit Front)
L - Left Hand

Valve Package

(Contact factory for options)

Thermostat Options

NC = No Controls

Vertical Floor Consoles

AE Air's vertical floor consoles are slim and extremely attractive. Their pleasing appearance allows them to blend with any decor. These products are engineered to be quiet and designed to be easy to install and service. These units are ideal for perimeter heating and cooling in hotels, apartments, hospitals, public office buildings, offices, corridors, and other multi-room buildings. Three models are available to meet any application: recessed, flat top console, and slope top console. They are available in 6 sizes with airflow from 300 through 1200 CFM to supply just the right amount of air. Available coils include 3 and 4 rows for 2-pipe systems, and 31, 41 (300-800 CFM only) split coils for 4-pipe systems.

FEATURES/ BENEFITS

Cabinets

All cabinets are constructed of heavy 18 gauge embossed galvanized steel to resist corrosion. Series VSB and Series VFB models are finished with an electrostatically applied, baked-on powder coating. The finish is an attractive light gray color. Wrap-around cabinet can be quickly and easily removed for service without the use of tools. Heavy duty "Stamped" Louver Grilles are standard.

Coils

Coils are available in standard and high capacity configuration and all include manual air vents. Coils are constructed of seamless copper tubing expanded to high efficiency aluminum fins to assure maximum heat transfer. Each coil is factory tested to 350 psig.

Drain Pans

The primary drain pan is constructed of galvanized steel and coated to resist corrosion. This pan extends under the entire coil and coil headers. An injection molded secondary drain pan provides complete condensate drainage from the primary pan and is located under the valve package (if provided). Secondary drain pan can be rotated 180 degrees to allow field piping to enter the unit from different locations.

Motors

Standard motors are 120V, 240V, or 277V three speed (1), PSC or ECM type with internal thermal overload protection. Motors have permanently lubricated sleeve bearings for long life. All motors are resiliently mounted with rubber bushings to assure quiet, vibration-free

operation and are easily removed.

(1) The size 3 PSC motor (model 3VFB/VSB/VCB) may not start on low speed due to low starting torque. These units must be wired to start on either Medium or High speed.

Filters

A 1/2 inch permanent filter is provided as standard on all units. The filter is easily removed from the front of the unit without tools.

Electrical

All electrical components are factory routed to a single electrical compartment on each unit. All field wiring connections are made at this electrical compartment. Electrical Service Switch is standard on ALL models.

Options

A wide variety of two and four-pipe control systems are available with unit mounted or remote thermostats. Standard options include valve cycle control systems.

Other options include three speed switches, various motor voltages, and manual or motorized fresh air damper. See "Model Number Nomenclature" on Page 2 for unit options and Page 4 for control options. Fresh air wall box is fabricated of aluminum with drain holes and a double set of louvers in series to prevent moisture draw through.

Vertical Floor Consoles

UNIT SELECTION

General

The achievement of an efficient fan-coil system is dependent upon accurate system design and proper equipment selection. Variations, limitations and control of fan-coil systems, design conditions and design load calculations are not described in detail in this catalog. More detailed information may be found in the ASHRAE Guide.

The mechanical system designer must select the unit types best suited to the overall system before the actual unit sizes can be determined. The factors that generally influence this decision are intended building usage, building layout, architectural and aesthetic values, economics, geographical location, and type of maintenance service available. The general results may be a mixture of various unit types within a given system. First Co. manufactures a fan-coil unit to meet your every need.

Basic Design Data

Prior to selecting the individual unit sizes, the design engineer must fix or determine the following factors:

1. Inside and outside wet and dry bulb design temperatures.
2. Method of introducing the ventilation air.
3. Wet and dry bulb temperatures of the air mixture entering the unit coil.
4. Total and sensible heat gains and losses of the area to be served.
5. Properties of the heating and cooling medium.
6. Available electric power service.
7. Any special design requirements of the building or system.

Selection of Unit Size

The capacity ratings presented in this catalog are provided for initial unit selection only. Unit size selection should be determined by using First Co.'s fan-coil selection computer program. Water cooling and heating capacities, unit airflow, and static pressure are all incorporated into the program to provide the best possible selection. Consult your First Co. representative for a selection tailored to your application.

Unit sizes for the ideal system should be selected by calculating the peak load requirements due to unusually high occupancy or severe climatic conditions and with fan operating at high speed. Ordinary day-to-day cooling and heating requirements are then achieved at low and medium speeds. Ventilation requirements should be considered along with heating and cooling capacity to determine the proper unit size. Fresh air must be tempered before entering the unit if freezing conditions are expected.

Cooling Coil Requirements

Having checked the minimum unit size to meet the ventilation requirement, the unit size is generally selected based on matching the sensible cooling capacity of the unit with the calculated requirements when operating at high speed.

Coil Types

Standard and high capacity coil types are available for all models.

Standard coils are designed to meet both the cooling and heating requirements in a typical system.

High capacity coils are designed to meet cooling and heating loads that exceed typical system requirements for ceiling units.

Heating Requirements

Heating requirements for two-pipe systems are generally met by employing the same water flow rate as cooling and adjusting the entering hot water temperature to obtain a matching unit heat output at low fan speed. Four-pipe systems are generally designed by specifying the flow rate through the separate heating coil to meet the required heat load with the fan operating at low speed.

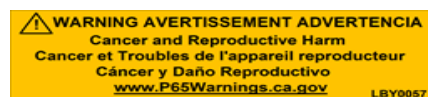

Vertical Floor Consoles

MOTOR / BLOWER PERFORMANCE

Air Volume Capacity / VCB, VFB, VSB for PSC Motor

UNIT		CGM @ 0.0 E.S.P. FOR FAN SPEED INDICATED			HIGH SPEED CFM @ E.S.P. INDICATED			
MODEL	SIZE	HIGH	MED	LOW	0.05	0.10	0.15	0.20
VC	3	280	245	210	255	230	205	175
	4	400	320	220	370	330	290	230
VF	6	600	430	320	570	540	510	480
	8	800	680	580	760	730	700	660
VS	10	1000	880	670	970	920	880	830
	12	1220	1030	780	1170	1120	1070	1020

Notes:

1. Values are standard CFM at sea level, 70 degree EAT. with dry coil.
2. P.S.C. - inches water.
3. Values include filter and / or grille where applicable.

Motor Data / VC, VF, VS PSC

MOTOR SPEED	UNIT SIZE											
	3		4		6		8		10*		12*	
	NOMINAL HP 1/20		NOMINAL HP 1/12		NOMINAL HP 1/8		NOMINAL HP 1/6		NOMINAL HP 1/8 (2)		NOMINAL HP 1/6 (2)	
	Amps	Watts	Amps	Watts	Amps	Watts	Amps	Watts	Amps	Watts	Amps	Watts
120 VOLT - 1 PH - 60 Hz PSC MOTOR												
HIGH	.80	95	1.0	105	1.8	200	2.2	250	3.0	350	4.6	520
MEDIUM	.45	60	.60	70	1.1	140	2.0	210	2.4	275	3.0	330
LOW	.40	50	.45	55	.80	90	1.6	170	1.8	210	2.1	230

Notes:

- * Total unit motor amps and watts shown for 2 motors. (Unit size 10 and 12)

In keeping with its policy of continuous progress and product improvement, AE Air reserves the right to make changes without notice.

Vertical Floor Consoles

MOTOR / BLOWER PERFORMANCE

Air Volume Capacity / VCB, VFB, VSB for ECM Motor

MODEL	HP	AMPS / 120V	SPEED TAPS	External Static Pressure (inches of water)				
				0.0	0.05	0.10	0.15	0.20
3VCX	1/20	0.66	HIGH	280	260	250	240	230
		0.49	MEDIUM	240	230	220	200	190
		0.37	LOW	210	190	170	150	140
4VCX	1/10	0.8	HIGH	400	370	350	330	310
		0.4	MEDIUM	320	290	250	230	200
		0.2	LOW	220	180	150	110	90
6VCX	1/10	1.4	HIGH	600	570	550	530	510
		0.6	MEDIUM	430	410	390	370	340
		0.4	LOW	320	300	270	220	190
8VCX	1/4	2.5	HIGH	800	780	750	730	710
		1.7	MEDIUM	680	660	630	600	580
		1.1	LOW	580	560	530	500	480
10VCX	1/7 (2)	2.9	HIGH	1000	980	950	920	900
		2.1	MEDIUM	880	850	820	780	750
		1.1	LOW	670	630	590	550	500
12VCX	1/7 (2)	4.2	HIGH	1210	1200	1190	1170	1150
		2.9	MEDIUM	1050	1050	1020	1000	980
		1.6	LOW	810	790	750	710	670

Motor Data / VCX, VFX, VSX ECM

MOTOR SPEED	UNIT SIZE											
	3		4		6		8		10		12	
	NOMINAL HP 1/20		NOMINAL HP 1/10		NOMINAL HP 1/10		NOMINAL HP 1/4		NOMINAL HP 1/7 (2)		NOMINAL HP 1/7 (2)	
	AMPS	WATTS	AMPS	WATTS	AMPS	WATTS	AMPS	WATTS	AMPS	WATTS	AMPS	WATTS
120V 1PH 60 Hz EC MOTOR												
HIGH	0.66	43	0.8	63	1.4	105	2.5	200	2.9	234	4.2	360
MEDIUM	0.49	30	0.4	33	0.6	95	1.7	126	2.1	166	2.9	243
LOW	0.37	22	0.2	14	0.4	90	1.1	82	1.1	85	1.6	122

Notes:

* Total unit motor amps and watts shown for 2 motors. (Unit size 10 and 12)

Coil Ratings

COOLING COIL RATINGS

Standard Coil - Water Cooling Capacity Ratings - VCB, VFB, VSB (3 row)

UNIT SIZE	COOLING CAPACITY		GPM	WATER P.D. (Ft. Wtr.)
	TOTAL BTUH	SENSIBLE BTUH		
3	8,000	6,200	1.8	7.0
4	12,400	9,300	2.7	18.5
6	17,300	13,400	3.8	14.2
8	22,000	17,400	4.9	12.8
10	24,500	20,000	5.7	9.8
12	26,700	26,400	7.0	11.5

High Capacity Coil - Water Cooling Capacity Ratings - VCB, VFB, VSB (4 row)

UNIT SIZE	COOLING CAPACITY		GPM	WATER P.D. (Ft. Wtr.)
	TOTAL BTUH	SENSIBLE BTUH		
3	9,200	6,800	2.0	11.5
4	14,000	10,000	3.1	29.6
6	19,800	14,600	4.4	11.8
8	26,900	19,700	6.0	22.8
10	26,400	20,800	6.2	8.5
12	31,300	22,800	8.2	9.7

Notes:

1. Rated in accordance with ARI Standard 440. Cooling capacities based on 80 deg. DB / 67 deg. WB entering air, 45 deg. entering water, 10 deg. water temperature rise and high fan speed with standard 120V/1PH/60Hz motor.
2. For cooling coil capacities at conditions other than listed, refer to application guide or consult your Sales Representative.

HEATING COIL RATINGS

Standard Coil - Water Heating Capacity Ratings - VCB, VFB, VSB (3 row)

UNIT SIZE	HEATING CAPACITY BTUH	GPM	WATER P.D. (Ft. Wtr.)
3	23,500	1.6	4.5
4	34,200	2.3	8.6
6	49,400	3.3	7.8
8	64,500	4.3	8.2
10	87,000	5.8	10.4
12	106,300	7.1	15.9

High Capacity Coil - Water Heating Capacity Ratings - VCB, VFB, VSB (4 row)

UNIT SIZE	HEATING CAPACITY BTUH	GPM	WATER P.D. (Ft. Wtr.)
3	25,200	1.7	4.8
4	36,600	2.4	11.3
6	52,500	3.5	10.2
8	69,500	4.6	11.5
10	92,200	6.1	9.5
12	113,000	7.5	13.7

1-Row Coil - Water Heating Capacity Ratings - VCB, VFB, VSB

UNIT SIZE	HEATING CAPACITY BTUH	GPM	WATER P.D. (Ft. Wtr.)
3	12,400	0.8	2.4
4	18,200	1.2	6.1
6	26,000	1.7	12.7
8	33,700	2.2	22.7
10	33,600	2.2	5.9
12	41,200	2.7	8.8

Notes:

1. Heating coils rated at 70 deg. DB entering air, 180 deg. entering water, 30 deg. water temperature drop and high fan speed with standard 120V/1PH/60Hz motor.
2. For heating capacities at conditions other than listed, consult your First Co. Representative or the factory.

VCB Physical Dimensions

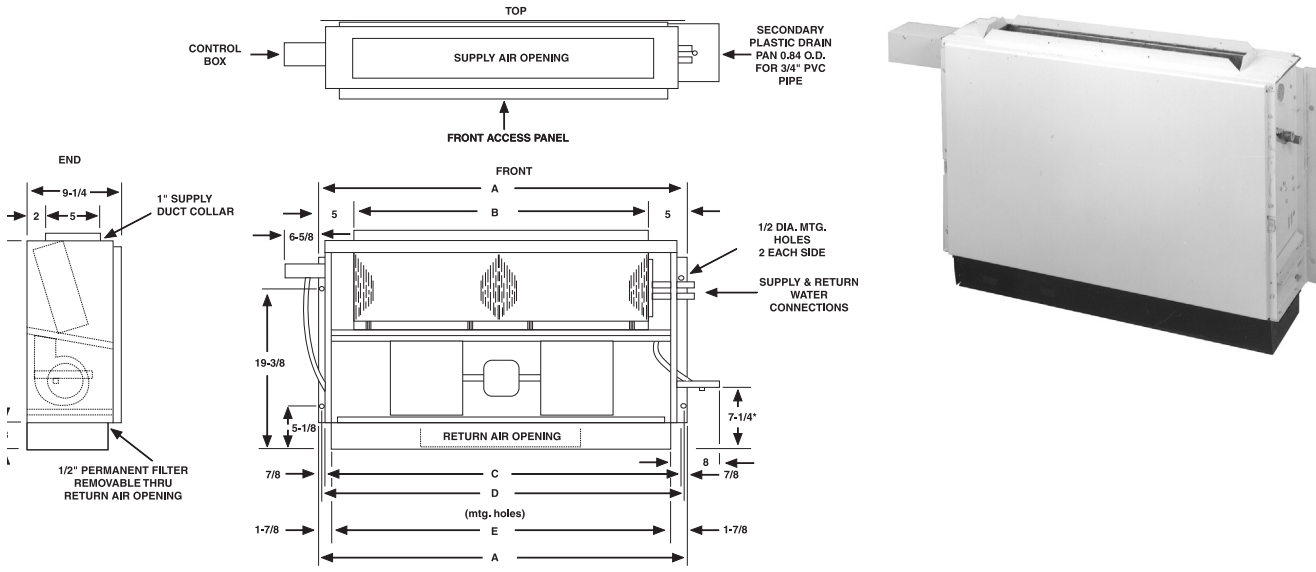

* DIMENSIONS VARY FOR UNITS WITH NON-STANDARD VALVE PACKAGES.

GENERAL DIMENSIONS						COIL CONN SIZE	
MODEL	A	B	C	D	E	COOLING	HEATING
3 VCB	27-1/2	18	25-1/2	26-1/2	23-3/4	5/8 O.D. SWEAT	5/8 O.D. SWEAT
4 VCB	35-1/2	26	33-1/2	34-1/2	31-3/4		
6 VCB	43-1/2	34	41-1/2	42-1/2	39-3/4		
8 VCB	51-1/2	42	49-1/2	50-1/2	47-3/4		
10 VCB	59-1/2	50	57-1/2	58-1/2	55-3/4		
12 VCB	67-1/2	58	65-1/2	66-1/2	63-3/4		

- NOTES:**
- 1) ALL DIMENSIONS IN INCHES.
 - 2) COIL CONNECTION TOLERANCE $\pm 1/4"$
 - 3) HAND OF UNIT DETERMINED BY COOLING COIL CONNECTION WHEN FACING THE FRONT OF UNIT.

VCB HEADER LOCATIONS									
RIGHT HAND	X1	Y1	X2	Y2	X3	Y3	X4	Y4	
3 ROW	4.75	18.13	3.00	17.50	---	---	---	---	
4 ROW	5.5	18.50	3.00	17.50	---	---	---	---	
3/1 ROW	4.63	18.13	3.13	17.50	6.88	15.50	3.88	21.50	
3/2 ROW	4.63	18.13	3.13	17.50	7.63	15.88	3.88	21.88	
4/1 ROW	5.50	15.80	3.13	17.50	7.75	15.50	4.88	21.88	
3 ROW	5.25	18.13	3.25	17.25	---	---	---	---	
4 ROW	6.25	15.80	3.25	17.25	---	---	---	---	
3/1 ROW	5.38	18.13	3.25	17.25	7.38	16.00	4.75	21.75	

(LEFT HAND UNIT SHOWN)

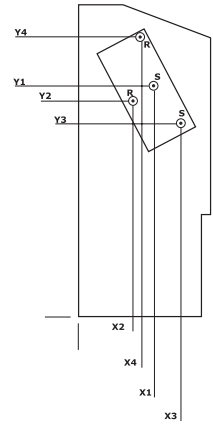

VCB HEADER LOCATIONS									
LEFT HAND	X1	Y1	X2	Y2	X3	Y3	X4	Y4	
3 ROW	4.75	18.13	3.00	17.50	---	---	---	---	
4 ROW	5.50	18.50	3.00	17.50	---	---	---	---	
3/1 ROW	4.63	18.13	3.13	17.50	7.00	15.13	4.13	21.50	
3/2 ROW	4.63	18.13	3.13	17.50	7.00	15.13	4.88	21.88	
4/1 ROW	5.50	18.50	3.13	17.50	7.63	16.00	4.63	22.25	
3 ROW	5.25	18.13	3.25	17.25	---	---	---	---	
4 ROW	6.25	18.50	3.25	17.25	---	---	---	---	
3/1 ROW	5.38	18.13	3.25	17.25	7.63	15.50	5.00	21.13	

VSB Physical Dimensions

NOTES:

- 1) ALL DIMENSIONS IN INCHES.
- 2) ALL DIMENSIONS ± 1/4".
- 3) CABINET TOLERANCE ± 1/16".
- 4) 24" CLEARANCE IN FRONT OF THE UNIT IS REQUIRED FOR SERVICE.
- 3) HAND OF UNIT DETERMINED BY COOLING COIL CONNECTION WHEN FACING THE FRONT OF UNIT.
- 6) COIL CONNECTION TOLERANCE ± 1/4".

GENERAL DIMENSIONS			
SIZE MODEL	A	COIL CONNECTION	
		COOLING	HEATING
3 VSB	43	5.8" O.D. SWEAT	5.8" O.D. SWEAT
4 VSB	51		
6 VSB	59		
8 VSB	67		
10 VSB	75		
12 VSB	83		

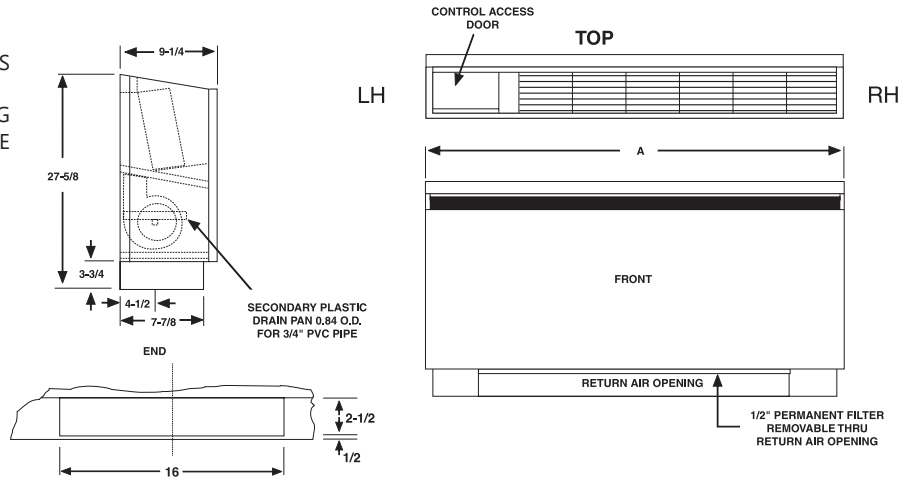

UNIT SIZES 10 & 12
Have two openings 2" apart centered on center line.

NOTE: Outside fresh air must be tempered before entering the unit if freezing conditions are expected.

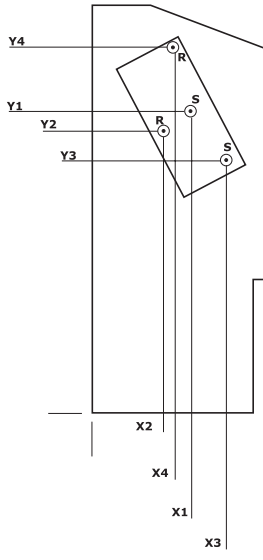
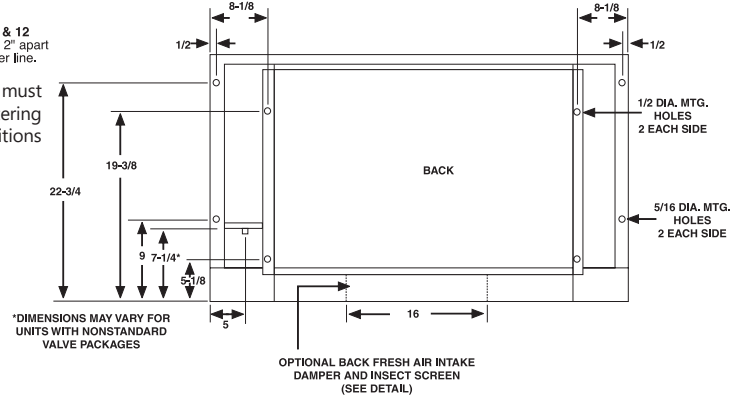

← (LEFT HAND UNIT SHOWN)

VSB HEADER LOCATIONS								
LEFT HAND	X1	Y1	X2	Y2	X3	Y3	X4	Y4
3 ROW	4.75	18.13	3.00	17.50	---	---	---	---
4 ROW	5.50	18.50	3.00	17.50	---	---	---	---
3/1 ROW	4.63	18.13	3.13	17.50	7.00	15.13	4.13	21.50
3/2 ROW	4.63	18.13	3.13	17.50	7.00	15.13	4.88	21.88
4/1 ROW	5.50	18.50	3.13	17.50	7.63	16.00	4.63	22.25
3 ROW	5.25	18.13	3.25	17.25	---	---	---	---
4 ROW	6.25	18.50	3.25	17.25	---	---	---	---
3/1 ROW	5.38	18.13	3.25	17.25	7.63	15.50	5.00	21.13

VSB HEADER LOCATIONS								
RIGHT HAND	X1	Y1	X2	Y2	X3	Y3	X4	Y4
3 ROW	4.75	18.13	3.00	17.50	---	---	---	---
4 ROW	5.50	18.50	3.00	17.50	---	---	---	---
3/1 ROW	4.63	18.13	3.13	17.50	6.88	15.50	3.88	21.50
3/2 ROW	4.75	18.13	3.13	17.50	7.63	15.88	3.88	21.88
4/1 ROW	5.50	15.50	3.13	17.50	7.75	15.50	4.88	21.88
3 ROW	5.25	18.13	3.25	17.25	---	---	---	---
4 ROW	6.25	15.50	3.25	17.25	---	---	---	---
3/1 ROW	5.25	18.13	3.25	17.25	7.38	16.00	4.75	21.75

VFB Physical Dimensions



- NOTES:**
- 1) ALL DIMENSIONS IN INCHES.
 - 2) ALL DIMENSIONS $\pm 1/4"$.
 - 3) CABINET TOLERANCE $\pm 1/16"$.
 - 4) 24" CLEARANCE IN FRONT OF THE UNIT IS REQUIRED FOR SERVICE.
 - 5) HAND OF UNIT DETERMINED BY COOLING COIL CONNECTION WHEN FACING THE FRONT OF UNIT.
 - 6) COIL CONNECTION TOLERANCE $\pm 1/4"$.

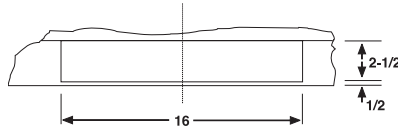
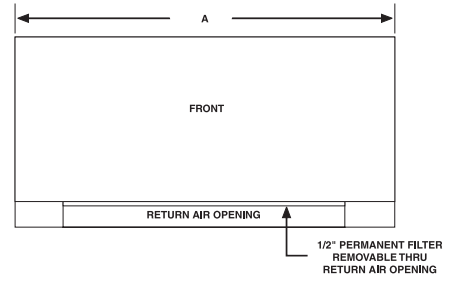
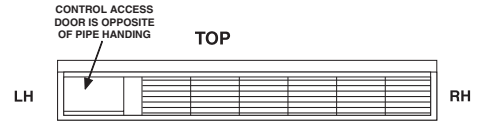

UNIT SIZES 10 & 12
Have two openings 2" apart centered on center line.

NOTE: Outside fresh air must be tempered before entering the unit if freezing conditions are expected.

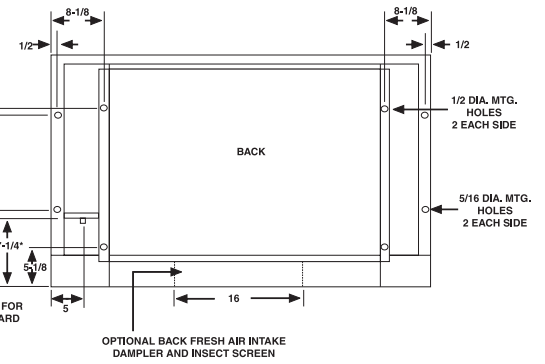

GENERAL DIMENSIONS			
SIZE MODEL	A	COIL CONNECTION	
		COOLING	HEATING
3 VFB	43	5.8" O.D. SWEAT	5.8" O.D. SWEAT
4 VFB	51		
6 VFB	59		
8 VFB	67		
10 VFB	75		
12 VFB	83		

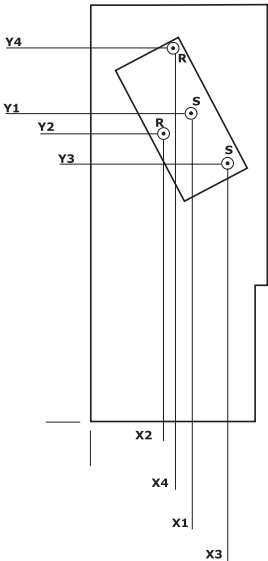

(LEFT HAND UNIT SHOWN)

VFB HEADER LOCATIONS									
	RIGHT HAND	X1	Y1	X2	Y2	X3	Y3	X4	Y4
3-8V	3 ROW	4.75	18.13	3.00	17.50	---	---	---	---
	4 ROW	5.50	18.50	3.00	17.50	---	---	---	---
	3/1 ROW	4.63	18.13	3.13	17.50	6.88	15.50	3.88	21.50
	3/2 ROW	4.75	18.13	3.13	17.50	7.63	15.88	3.88	21.88
10-12V	4/1 ROW	5.50	15.50	3.13	17.50	7.75	15.50	4.88	21.88
	3 ROW	5.25	18.13	3.25	17.25	---	---	---	---
	4 ROW	6.25	15.50	3.25	17.25	---	---	---	---
	3/1 ROW	5.25	18.13	3.25	17.25	7.38	16.00	4.75	21.75

VFB HEADER LOCATIONS									
	LEFT HAND	X1	Y1	X2	Y2	X3	Y3	X4	Y4
3-8V	3 ROW	4.75	18.13	3.00	17.50	---	---	---	---
	4 ROW	5.50	18.50	3.00	17.50	---	---	---	---
	3/1 ROW	4.63	18.13	3.13	17.50	7.00	15.13	4.13	21.50
	3/2 ROW	4.63	18.13	3.13	17.50	7.00	15.13	4.88	21.88
10-12V	4/1 ROW	5.50	18.50	3.13	17.50	7.63	16.00	4.63	22.25
	3 ROW	5.25	18.13	3.25	17.25	---	---	---	---
	4 ROW	6.25	18.50	3.25	17.25	---	---	---	---
	3/1 ROW	5.38	18.13	3.25	17.25	7.63	15.50	5.00	21.13

Guide Specifications - Vertical Floor Consoles

Furnish and install AE Air's vertical floor consoles as indicated on the plans and specifications. Types, sizes, and performance shall be as indicated in the schedule.

Casings and Cabinets

Flat Top Floor Model (VFB) and Slope Top Floor Model (VSB) - Cabinet shall be a vertical console type enclosure fabricated of heavy 18 gauge galvanized steel and finished with an electrostatically applied, baked-on light gray paint. Cabinet shall include a discharge grille angled to provide optimal air discharge and full width electrical and piping compartments. The discharge grille shall be made of heavy-duty, 18 gauge stamped steel and painted to match unit color. Units provided with unit mounted controls shall have a single access door. Cabinet shall be easily removed without tools for service.

Basic Unit (VCB) - Basic unit shall consist of base casing and removable front panel fabricated of heavy gauge galvanized steel with top duct discharge opening for installation in custom enclosure furnished by contractor.

Electrical

Unit shall have an electrical box providing a single location for all field wiring connections and a factory installed electrical Service Switch.

Coils

Coils shall have high efficiency aluminum fins with mechanically expanded copper tubes. All water coils shall have a manual air vent. Coil performance shall be as indicated in the schedule.

Fan Assembly

Fans shall be centrifugal, forward curved, and dynamically balanced for smooth, quiet operation. Fan housing shall be fabricated of heavy gauge galvanized steel and be easily removed, thus allowing complete service access to the fans and motors.

Motors

All units shall have PSC or ECM (120/1/60) (208-230/1/60) (277/1/60) three speed motors (1) with permanently lubricated sleeve bearings, inherent thermal overload protection with automatic reset, and resilient rubber motor mounts. (1) The size 3 PSC motor (model 3VFB/VSB/VCB) may not start on low speed due to low starting torque. These units must be wired to start on either Medium or High speed.

Speed Control (optional)

Units shall have a (unit) (wall) mounted three speed switch with integral on/off switch which shall provide high / medium / low fan speed control.

Drain Pan

Primary drain pan shall be constructed of galvanized steel and coated to resist corrosion. Secondary drain pan shall be constructed of injection molded plastic. Secondary drain pan shall be capable of rotating 180 degrees to allow field piping to enter the unit from different locations.

Insulation

Cabinet insulation shall be 1/2" multi-density glass fiber.

Filter

Filter shall be permanent type and cleanable.

Options

Valve Packages - Valve packages shall consist of various combinations of 2-way or 3-way motorized valves and/or combination balance/shut-off valves on the supply and return piping.

Fresh Air Kit - A manual or motorized fresh air damper shall be provided by the manufacturer for field installation.

Tamperproof Access Door - Units shall be provided with tamperproof access door on the thermostat/fan control compartment.

Vertical Floor Consoles

SHIPPING WEIGHTS

Approximate shipping weights (lbs.)

UNIT TYPE	UNIT SIZE					
	3	4	6	8	10	12
VCB	55	70	80	95	115	130
VFB / VSB	85	97	110	125	145	165

Note:

1. Approximate shipping weights do not include valve packages, hot water coils, electric heaters, or other options.

FRESH AIR WALL BOX

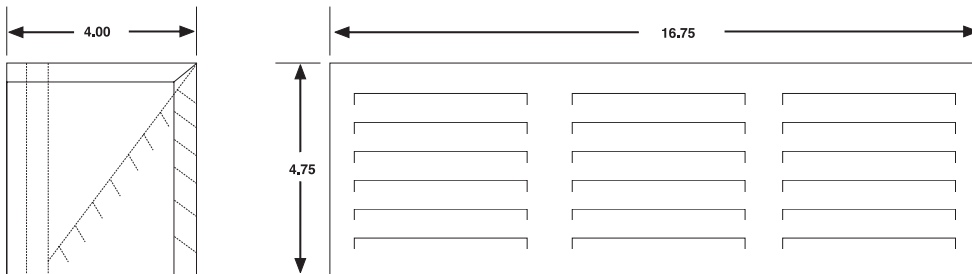

UNIT SIZES 10 & 12
Require two fresh air wall boxes.

NOTE: Outside fresh air must be tempered before entering the unit if freezing conditions are expected.

MOTORIZED AIR DAMPER



919-9
For sizes 3 through 8
919-10
For sizes 10 and 12

Vertical Floor Consoles

Thermostat Options For Available Electric Valve Packages

THERMOSTAT OPTIONS FOR ELECTRIC VALVE PACKAGES					
2 Pipe - Valve Cycle					
SYSTEM	THERMOSTAT CONTROLS	CONTROL VALVE TYPE	CHANGEOVER CONTROL and LOCATION	THERMOSTAT TYPE	ORDER OPTION NUMBER
Heating and Cooling	Heat-Off-Cool Constant Fan Hi-Med-Low	Motorized 2-way or 3-way Normally closed.	Manual Heat-Cool Switch on Thermostat	Unit Mount Wall Mount Unit Tamperproof	A1 A2 A3
	On-Off Constant Fan Hi-Med-Low	Motorized 3-way Normally closed.	Automatic (1) Aquistat - Factory Mounted on Supply Line	Unit Mount Wall Mount Unit Tamperproof	B1 (2) B2 B3
		Motorized 2-way or 3-way Normally closed.	Manual Summer - Winter Switch (switch must be field supplied)	Unit Mount Wall Mount Unit Tamperproof	C1 C2 C3
Cooling Only	On-Off Constant Fan Hi-Med-Low	Motorized 2-way or 3-way Normally closed.	None	Unit Mount Wall Mount Unit Tamperproof	D1 D2 D3
Heating Only	On-Off Constant Fan Hi-Med-Low	Motorized 2-way or 3-way Normally closed.	None	Unit Mount Wall Mount Unit Tamperproof	E1 E2 E3
4 Pipe - Valve Cycle					
SYSTEM	THERMOSTAT CONTROLS	CONTROL VALVE TYPE	CHANGEOVER CONTROL and LOCATION	THERMOSTAT TYPE	ORDER OPTION NUMBER
Heating and Cooling	Heat-Off-Cool Constant Fan Hi-Med-Low	Motorized 2-way or 3-way Normally closed.	Manual Heat-Cool Switch on Thermostat	Unit Mount Wall Mount Unit Tamperproof	M1 M2 M3
	On-Off Constant Fan Hi-Med-Low	Motorized 2-way or 3-way Normally closed.	Automatic 4 deg. Neutral Dead Band for sequenced heating & cooling, DPDT	Unit Mount Wall Mount Unit Tamperproof	N1 N2 N3
3-SPEED FAN SWITCH ONLY (no thermostat)					
				SWITCH TYPE	ORDER OPTION NUMBER
				Unit Mount Wall Mount Unit Tamperproof	L1 L2 L3

NOTES:

1. B1 option includes factory installed aquastat.
2. If valve package is desired with "B" options, select valve package number "3D".
3. Use "NC" for no controls.

**All thermostat options include
3 speed switches**



AE-Air
P.O. Box 270969 - Dallas, Texas 75227
Ph. (214) 388-5751 | Fax (214) 388-2255
www.ae-air.com

MARCH 2026